

# Trimmer Potentiometers

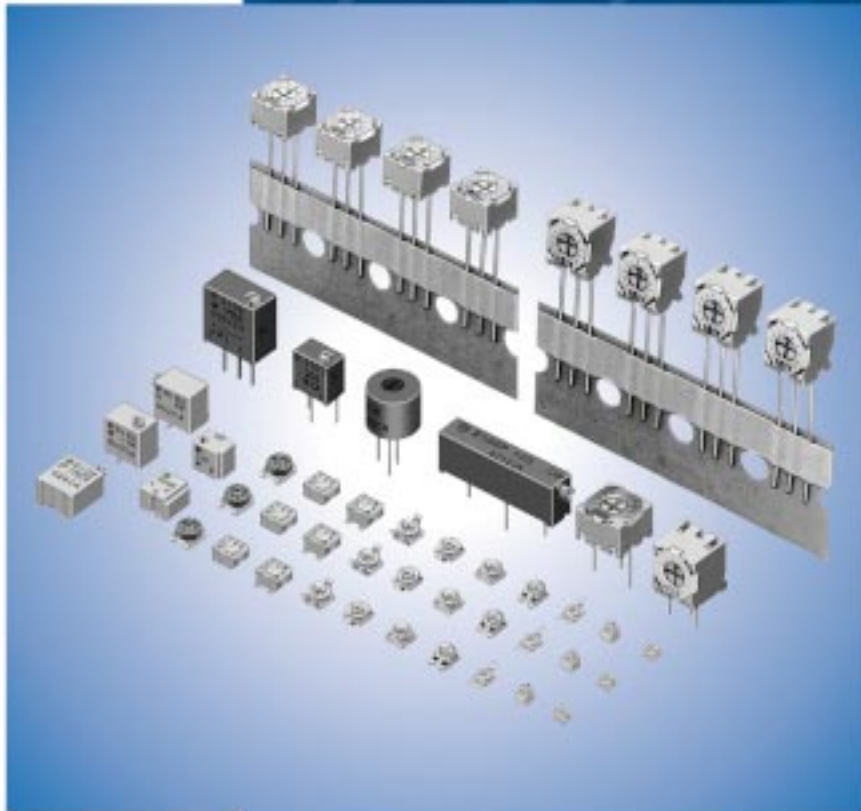

# CONTENTS

<b>Part Numbering</b>	2
<b>Selection Guide of Trimmer Potentiometers</b>	4
<b>1 SMD Open Type 2mm Size PVZ2 Series</b>	5
● PVZ2 Series Notice	7
<b>2 SMD Open Type 3mm Size PVZ3/PVS3/PVA3 Series</b>	9
● PVZ3/PVS3/PVA3 Series Notice	16
<b>3 SMD Sealed Type 2mm Size PVF2 Series</b>	19
● PVF2 Series Notice	21
<b>4 SMD Sealed Type 3mm Size PVG3 Series</b>	23
● PVG3 Series Notice	26
<b>5 SMD Sealed Type 4mm Size PVM4 Series</b>	28
● PVM4 Series Notice	31
<b>6 SMD Sealed Type Multi-turns PVG5/PV01 Series</b>	33
● PVG5/PV01 Series Notice	39
<b>7 Lead Sealed Type Single-turn PVC6/PV32/PV34 Series</b>	41
● PVC6/PV32/PV34 Series Notice	52
<b>8 Lead Sealed Type Multi-turns PV12/PV37/PV23/PV22/PV36 Series</b>	54
● PV12/PV37/PV23/PV22/PV36 Series Notice	71
<b>9 Angle Sensing Potentiometer SMD Dust-proof Type 12mm Size PVS1 Series</b>	73
● PVS1 Series Notice	75
<b>SMD Open Type and SMD Sealed Type PVM4A_C01 Series Specifications and Test Methods</b>	77
<b>SMD Sealed Type/Lead Sealed Type Specifications and Test Methods</b>	79
<b>Angle Sensing Potentiometer Specifications and Test Methods</b>	82
<b>Packaging</b>	83
<b>Recommended Adjustment Tools/Qualified Standards</b>	88

• The RoHS compliance means that we judge from EU Directive 2002/95/EC the products do not contain lead, cadmium, mercury, hexavalent chromium, PBB and PBDE, except exemptions stated in EU Directive 2002/95/EC annex and impurities existing in natural world.  
• This statement does not insure the compliance of any of the listed parts with any laws or legal imperatives developed by any EU members individually with regards to the RoHS Directive.

● Part Numbering

Trimmer Potentiometers

(Part Number)

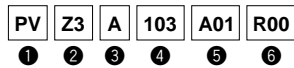

① Product ID

Product ID	
<b>PV</b>	Trimmer Potentiometers

② Series

③ Adjustment Direction /Lead Type

Code	Series	Code	Adjustment Direction/ Lead Type
<b>Z2</b>	SMD Open 2mm Size	<b>A</b>	Top
		<b>K</b>	Rear
<b>Z3</b>	SMD Open 3mm Size	<b>A</b>	Top
		<b>K</b>	Rear
		<b>R</b>	Rear
<b>S3</b>	SMD Open 3mm Size Stopper Low-profile	<b>A</b>	Top
<b>A3</b>	SMD Open 3mm Size	<b>A</b>	Top
<b>F2</b>	SMD Sealed type 2mm Size	<b>A</b>	Top
<b>G3</b>	SMD Sealed 3mm Size	<b>A</b>	Top, J-hook
		<b>G</b>	Top, Gull-wing
		<b>K</b>	Rear
<b>M4</b>	SMD Sealed 4mm Size	<b>A</b>	Top
<b>G5</b>	SMD Sealed 5mm Square 11-turns	<b>A</b>	Top
		<b>H</b>	Side
<b>01</b>	SMD Sealed 6mm Square 12-turns	<b>P</b>	Side
		<b>W</b>	Top
		<b>X</b>	Side
<b>C6</b>	Lead Sealed 6mm Square Single-turn	<b>A</b>	Top, Triangle
		<b>D</b>	Top, Triangle
		<b>E</b>	Side, Triangle
		<b>G</b>	Side, Triangle
		<b>H</b>	Side, Triangle
		<b>M</b>	Top, Inline
		<b>Q</b>	Side, Inline
<b>32</b>	Lead Sealed 6mm Round Single-turn	<b>H</b>	Top, Triangle
		<b>P</b>	Top, Triangle
		<b>R</b>	Top, Inline
		<b>N</b>	Side, Triangle
		<b>T</b>	Side, Triangle
<b>34</b>	Lead Sealed 9mm Square Single-turn	<b>S</b>	Side, Triangle
		<b>F</b>	Top, Triangle
		<b>P</b>	Top, Triangle
		<b>H</b>	Side, Triangle
		<b>X</b>	Side, Triangle
<b>12</b>	Lead Sealed 7mm Round 4-turns	<b>W</b>	Side, Inline
		<b>H</b>	Top, Triangle
		<b>P</b>	Top, Triangle
		<b>T</b>	Side, Triangle
<b>22</b>	Lead Sealed 31mm Rectangular 22-turns	<b>S</b>	Side, Triangle
		<b>L</b>	Side
		<b>Y</b>	Side, Triangle

<b>23</b>	Lead Sealed 19mm Rectangular 15-turns	<b>P</b>	Side, Triangle
		<b>Y</b>	Side, Triangle
<b>36</b>	Lead Sealed 10mm Square 25-turns	<b>W</b>	Top, Inline
		<b>Y</b>	Top, Triangle
		<b>P</b>	Side, Triangle
		<b>X</b>	Side, Inline
		<b>Z</b>	Side, Triangle
<b>37</b>	Lead Sealed 6mm Square 12-turns	<b>W</b>	Top, Triangle
		<b>Y</b>	Top, Inline
		<b>P</b>	Side, Triangle
		<b>X</b>	Side, Triangle
		<b>Z</b>	Side, Inline

④ Total Resistance

Expressed by three figures. The unit is ohm. The first and second figures are significant digits, and the third figure expresses the number of zeros which follow the two figures.

Ex.)

Code	Total Resistance
<b>100</b>	10ohm
<b>102</b>	1000ohm
<b>104</b>	100000ohm (=100kohm)

⑤ Individual Specification

Code	Series	Individual Specification Code
<b>A01</b>	<b>PVZ2/PVZ3/PVS3/ PVA3/PV32/PV12</b>	Standard Type
<b>C01</b>	<b>PVG3/PVM4/PVG5/PV01/ PVC6/PV34/PV22/PV23/ PV36/PV37</b>	Standard Type
<b>A04</b>	<b>PVZ2</b>	Ultra-thin Type
<b>C01</b>	<b>PVZ3</b>	High-heat Resistance Type (for Top Adjustment)
<b>E01</b>	<b>PVZ3</b>	High-heat Resistance Type (for Rear Adjustment)
<b>D01</b>	<b>PVM4</b>	High-liability Type
<b>C31</b>	<b>PV36/PV37</b>	Radial Taping
<b>C04</b>	<b>PVC6</b>	Radial Taping
<b>A11</b>	<b>PVF2</b>	Standard Type (Resistance Change Characteristics : Linear)
<b>A41</b>	<b>PVF2</b>	Standard Type (Resistance Change Characteristics : Log curve)
<b>A81</b>	<b>PVF2</b>	Standard Type (Resistance Change Characteristics : Log curve)
<b>A51</b>	<b>PVF2</b>	Standard Type (Resistance Change Characteristics : Log-log curve)
<b>A91</b>	<b>PVF2</b>	Standard Type (Resistance Change Characteristics : Log-log curve)

⑥ Packaging

Code	Packaging
<b>A00</b>	Ammo Pack
<b>B00</b>	Bulk
<b>M00*</b>	Magazine
<b>R00</b>	Reel

\* M12 for PV36P Type and M15 for PV36W/Y/X/Z Type.

### Angle Sensing Potentiometers

(Part Number) 

PV	S1	A	103	A01	R00
----	----	---	-----	-----	-----

  
1
2
3
4
5
6

**1** Product ID

Product ID	
<b>PV</b>	Trimmer Potentiometers (Rotary Position Sensor)

**2** Series

Code	Series
<b>S1</b>	Dust-proof Type 12mm Size

**3** Terminal Shape

Code	Terminal Shape
<b>A</b>	SMD Type
<b>L</b>	Lead Type

**4** Total Resistance

Expressed by three figures. The unit is ohm. The first and second figures are significant digits, and the third figure expresses the number of zeros which follow the two figures.

Ex.)

Code	Total Resistance
<b>103</b>	10000 ohm (=10k ohm)

\* PVS1 Series will be changed to new part number since Oct. 1, 2004. Details is as follows.

(Part Number) 

SV	01	A	103	AE	A01	R00
----	----	---	-----	----	-----	-----

  
1
2
3
4
5
6
7

**1** Product ID

Product ID	
<b>SV</b>	Rotary Position Sensor

**2** Series

Code	Series
<b>01</b>	Carbon Rotary Position Sensor

**3** Terminal Shape

Code	Terminal Shape
<b>A</b>	SMD Type
<b>L</b>	Lead Type

**4** Total Resistance

Expressed by three figures. The unit is ohm. The first and second figures are significant digits, and the third figure expresses the number of zeros which follow the two figures.

Ex.)

Code	Total Resistance
<b>103</b>	10000 ohm (=10k ohm)

**5** Individual Specification Code

Code	Individual Specification Code
<b>A01</b>	SMD Type Standard
<b>A03</b>	Lead Type Standard

**6** Packaging

Code	Packaging
<b>B00</b>	Bulk
<b>R00</b>	Reel
<b>T00</b>	Tray

**5** Rotor Hole Shape/Rotor Hole Size

Code	Rotor Hole Shape/Rotor Hole Size
<b>AD</b>	D Hole/3.5mm Dia.
<b>AE</b>	D Hole/4.0mm Dia.
<b>CE</b>	T Hole/4.0mm Dia.

**6** Individual Specification Code

Code	Individual Specification Code
<b>A01</b>	SMD Type Standard
<b>A03</b>	Lead Type Standard

**7** Packaging

Code	Packaging
<b>B00</b>	Bulk
<b>R00</b>	Reel
<b>T00</b>	Tray



# Trimmer Potentiometers



## SMD Open Type 2mm Size PVZ2 Series

### ■ Features

1. Ultra-small and thin external dimensions of 2.1(W)x2.7(L)x0.85 max. (T)mm. (PVZ2A\_A04 Series)
2. Au plated termination achieves a high density P.C.B. mounting.
3. Cross-shaped driver slot allows for in-process automatic adjustment and it provides superior adjustability.
4. Two-piece parts construction achieves low cost and excellent quality.
5. Special resin substrate allows high peak temperature for reflow soldering.

### ■ Applications

- |                   |                         |
|-------------------|-------------------------|
| 1. Pick-up module | 2. LCD                  |
| 3. Cellular-phone | 4. PHS                  |
| 5. Pager          | 6. DVC                  |
| 7. Digital camera | 8. Portable audio, etc. |



PVZ2A

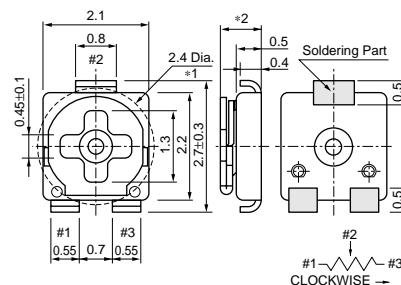

\*1 Driver Plate Rotation Area :  
Please do not place any components more than 0.7mm in height within this area.  
\*2 PVZ2A\_A01 : 0.9±0.1  
PVZ2A\_A04 : 0.8±0.05  
(Tolerance : ±0.2) in mm



PVZ2K

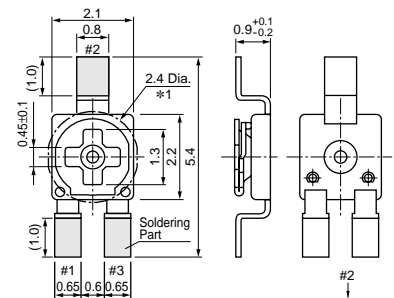

\*1. Driver Plate Rotation Area :  
Please do not place any components more than 0.7mm in height within this area.  
(Tolerance : ±0.2) in mm

Part Number	Power Rating	Soldering Method	Number of Turns (Effective Rotation Angle)	Total Resistance Value	TCR
PVZ2□501A01	0.1W(50°C)	Reflow/Soldering Iron	1(240°±10°)	500ohm ±30%	±500ppm/°C
PVZ2□102A01	0.1W(50°C)	Reflow/Soldering Iron	1(240°±10°)	1k ohm ±30%	±500ppm/°C
PVZ2□202A01	0.1W(50°C)	Reflow/Soldering Iron	1(240°±10°)	2k ohm ±30%	±500ppm/°C
PVZ2□302A01	0.1W(50°C)	Reflow/Soldering Iron	1(240°±10°)	3k ohm ±30%	±500ppm/°C
PVZ2□502A01	0.1W(50°C)	Reflow/Soldering Iron	1(240°±10°)	5k ohm ±30%	±500ppm/°C
PVZ2□103A01	0.1W(50°C)	Reflow/Soldering Iron	1(240°±10°)	10k ohm ±30%	±500ppm/°C
PVZ2□203A01	0.1W(50°C)	Reflow/Soldering Iron	1(240°±10°)	20k ohm ±30%	±500ppm/°C
PVZ2□303A01	0.1W(50°C)	Reflow/Soldering Iron	1(240°±10°)	30k ohm ±30%	±500ppm/°C
PVZ2□503A01	0.1W(50°C)	Reflow/Soldering Iron	1(240°±10°)	50k ohm ±30%	±500ppm/°C
PVZ2□104A01	0.1W(50°C)	Reflow/Soldering Iron	1(240°±10°)	100k ohm ±30%	±500ppm/°C
PVZ2□204A01	0.1W(50°C)	Reflow/Soldering Iron	1(240°±10°)	200k ohm ±30%	±500ppm/°C
PVZ2□304A01	0.1W(50°C)	Reflow/Soldering Iron	1(240°±10°)	300k ohm ±30%	±500ppm/°C
PVZ2□504A01	0.1W(50°C)	Reflow/Soldering Iron	1(240°±10°)	500k ohm ±30%	±500ppm/°C
PVZ2□105A01	0.1W(50°C)	Reflow/Soldering Iron	1(240°±10°)	1M ohm ±30%	±500ppm/°C
PVZ2□501A04	0.1W(50°C)	Reflow/Soldering Iron	1(240°±10°)	500ohm ±30%	±500ppm/°C
PVZ2□102A04	0.1W(50°C)	Reflow/Soldering Iron	1(240°±10°)	1k ohm ±30%	±500ppm/°C
PVZ2□202A04	0.1W(50°C)	Reflow/Soldering Iron	1(240°±10°)	2k ohm ±30%	±500ppm/°C
PVZ2□302A04	0.1W(50°C)	Reflow/Soldering Iron	1(240°±10°)	3k ohm ±30%	±500ppm/°C
PVZ2□502A04	0.1W(50°C)	Reflow/Soldering Iron	1(240°±10°)	5k ohm ±30%	±500ppm/°C
PVZ2□103A04	0.1W(50°C)	Reflow/Soldering Iron	1(240°±10°)	10k ohm ±30%	±500ppm/°C
PVZ2□203A04	0.1W(50°C)	Reflow/Soldering Iron	1(240°±10°)	20k ohm ±30%	±500ppm/°C
PVZ2□303A04	0.1W(50°C)	Reflow/Soldering Iron	1(240°±10°)	30k ohm ±30%	±500ppm/°C
PVZ2□503A04	0.1W(50°C)	Reflow/Soldering Iron	1(240°±10°)	50k ohm ±30%	±500ppm/°C
PVZ2□104A04	0.1W(50°C)	Reflow/Soldering Iron	1(240°±10°)	100k ohm ±30%	±500ppm/°C
PVZ2□204A04	0.1W(50°C)	Reflow/Soldering Iron	1(240°±10°)	200k ohm ±30%	±500ppm/°C

Continued on the following page. ↗

Continued from the preceding page.

Part Number	Power Rating	Soldering Method	Number of Turns (Effective Rotation Angle)	Total Resistance Value	TCR
PVZ2□304A04	0.1W(50°C)	Reflow/Soldering Iron	1(240°±10°)	300k ohm ±30%	±500ppm/°C
PVZ2□504A04	0.1W(50°C)	Reflow/Soldering Iron	1(240°±10°)	500k ohm ±30%	±500ppm/°C
PVZ2□105A04	0.1W(50°C)	Reflow/Soldering Iron	1(240°±10°)	1M ohm ±30%	±500ppm/°C

The blank column is filled with the code of adjustment direction A (top) or K (rear).

### Construction



### Standard Land Pattern

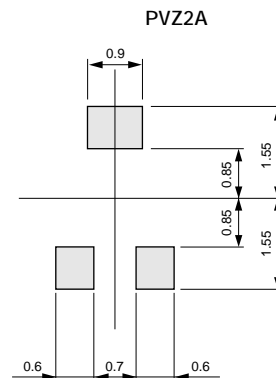

( in mm)  
Tolerance : ±0.1

### Construction

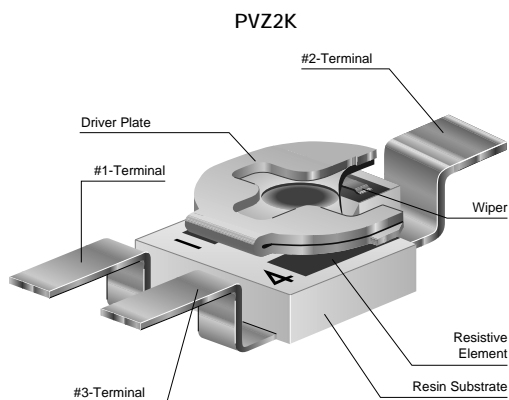

### Standard Land Pattern

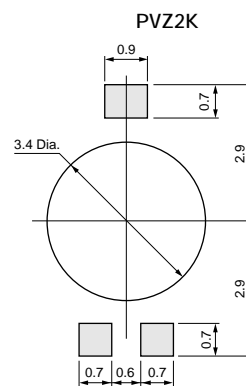

( in mm)  
Tolerance : ±0.1

### Characteristics

Humidity Exposure	Res. Change : +10, -2%
High Temperature Exposure	Res. Change : R≤50kohm...+2, -10% 50kohm<R...+2, -15%
Humidity Load Life	Res. Change : ±10%
Load Life	Res. Change : R≤50kohm...+2, -10% 50kohm<R...+2, -15%
Temperature Cycle	Res. Change : ±5%
Temperature Coefficient of Resistance	±500ppm/°C
Rotational Life	Res. Change : ±10% (10 cycles)

### ■ Notice (Operating and Storage Conditions)

1. Store in temperatures of -10 to +40 deg. C and relative humidity of 30-85%RH.
2. Do not store in or near corrosive gases.
3. Use within six months after delivery.
4. Open the package just before using.
5. Do not store under direct sunlight.
6. If you use the trimmer potentiometer in an environment other than listed below, please consult with a Murata factory representative prior to using.  
The trimmer potentiometer should not be used under

- the following environmental conditions:
- (1) Corrosive gaseous atmosphere  
(Ex. Chlorine gas, Hydrogen sulfide gas, Ammonia gas, Sulfuric acid gas, Nitric oxide gas, etc.)
  - (2) In liquid  
(Ex. Oil, Medical liquid, Organic solvent, etc.)
  - (3) Dusty / dirty atmosphere
  - (4) Direct sunlight
  - (5) Static voltage nor electric/magnetic fields
  - (6) Direct sea breeze
  - (7) Other variations of the above

### ■ Notice (Rating)

1. When using with partial load (rheostat), minimize the power depending on the resistance value.
2. The maximum input voltage to a trimmer potentiometer should not exceed  $(P.R)^{1/2}$  or the maximum operating voltage, whichever is smaller.
3. The maximum input current to a trimmer potentiometer should not exceed  $(P/R)^{1/2}$  or the allowable wiper current, whichever is smaller.
4. If the trimmer potentiometer is used in DC and high humidity conditions, please connect wiper (#2) for plus and resistive element (#1 or #3) for minus.

### ■ Notice (Soldering and Mounting)

1. Soldering
    - (1) Reflow soldering and Soldering Iron are available. Cannot be soldered using the flow soldering method. If you use the flow soldering method, the trimmer potentiometer may not function.
    - (2) Use our standard land dimension. Excessive land area causes displacement due to the effect of the surface tension of the solder. Insufficient land area leads to insufficient soldering strength of the chip.
    - (3) Standard soldering condition
      - (a) Reflow soldering :  
Refer to the standard temperature profile.
      - (b) Soldering iron:
        - >Temperature of tip 360 deg. C max.
        - >Soldering time 3 sec. max.
        - >Diameter 1mm max.
        - >Wattage of iron 30W max.
- Before using other soldering conditions than those listed above, please consult with Murata factory representative prior to using. If the soldering conditions are not suitable, e.g., excessive time and/or excessive temperature, the trimmer potentiometer may deviate from the specified characteristics.
- (4) Apply the appropriate amount of solder paste.

The thickness of solder paste should be printed from 100 micro m to 150 micro m and the dimension of land pattern used should be Murata's standard land pattern at reflow soldering. Insufficient amounts of solder can lead to insufficient soldering strength on PCB. Excessive amounts of solder may cause bridging between the terminals.

- (5) The soldering iron should not come in contact with the case of the trimmer potentiometer. If such contact does occur, the trimmer potentiometer may be damaged.
2. Mounting
    - (1) Do not apply excessive force (preferably 4.9N (Ref.; 500gf) max.), when the trimmer potentiometer is mounted to the PCB.
    - (2) Do not warp and/or bend PC board to prevent trimmer potentiometer from breakage.
    - (3) In chip placers, the recommended size of the cylindrical pick-up nozzle should be outer dimension 1.5-1.8mm dia. and inner dimension 1.3mm dia.
  3. Cleaning
    - (1) In case there is flux on the resistive element, clean sufficiently with cleaning solvents and completely remove all residual flux.
    - (2) Isopropyl-alcohol and Ethyl-alcohol are



## PVZ2 Series Notice

Continued from the preceding page.

applicable solvents for cleaning. If you use any other types of solvents, please evaluate

performance by your product.

### Reflow Soldering Standard Profile

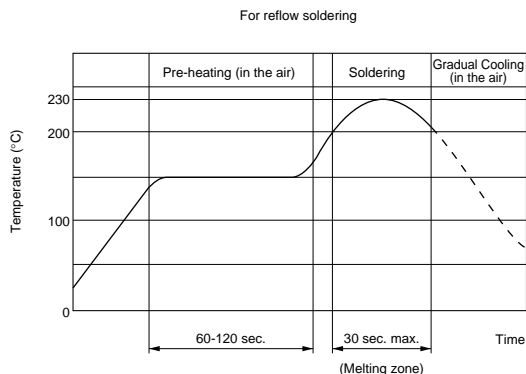

### Notice (Handling)

- Use suitable screwdrivers that fit comfortably in driver slot. We recommend the screwdriver below.  
\* Recommended screwdriver for manual adjustment  
PVZ2A\_A01=Murata P/N : KMDR090  
PVZ2A\_A04=Murata P/N : KMDR150
- Don't apply more than 4.9N (Ref.; 500gf) of twist and stress after mounting onto PCB to prevent contact intermittence. If excessive force is applied, the trimmer potentiometer may not function.

- Please use within the effective rotational angle.  
The potentiometer does not have a mechanical stop for over rotation. In cases out of effective rotational angle, the trimmer potentiometer may not function.
- When using a lock paint to fix slot position, please consult with a Murata factory representative prior to using to prevent corrosion and contact intermittence.

### Notice (Other)

- Please make sure that your product has been evaluated and confirmed against your specifications when our product is mounted to your product.
- Murata cannot guarantee trimmer potentiometer integrity when used under conditions other than those specified in this document.

# Trimmer Potentiometers



## SMD Open Type 3mm Size PVZ3/PVS3/PVA3 Series

### PVZ3 Series

#### ■ Features

1. Excellent solderability characteristics are achieved via special plating techniques on each termination.
2. Specially designed substrate prevents wicking of flux onto the top of the part body.
3. Funnel shaped adjustment slot allows for in-process automatic adjustment.
4. High-heat resistance type is available (PVZ3A\_C01/PVZ3K\_E01/PVZ3R\_E01).
5. Enlarged bottom termination enhance soldering strength while reducing the necessary land area required promoting high-density PCB mounting.
6. Flat surface is provided for smooth pick and place (PVZ3K only).
7. The standard position of driver plate is adjusted at the center normally, but another position is also available.
8. This product meets Pb-free.

#### ■ Applications

1. Optical pick up
2. Cordless telephones
3. CD players
4. FDD
5. Motor
6. CD-ROMs
7. Car stereos
8. TFT-LCD TV sets
9. Headphone stereos



PVZ3A

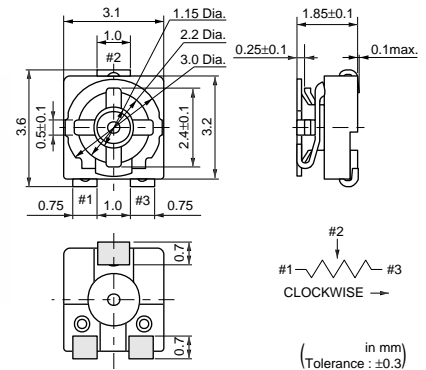

PVZ3K

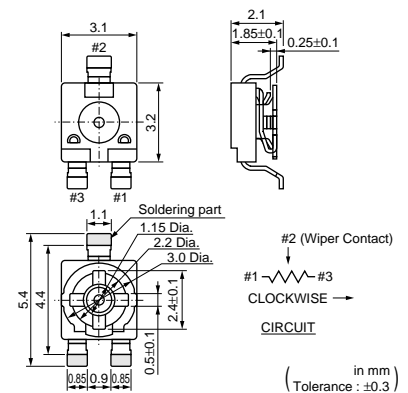

PVZ3R

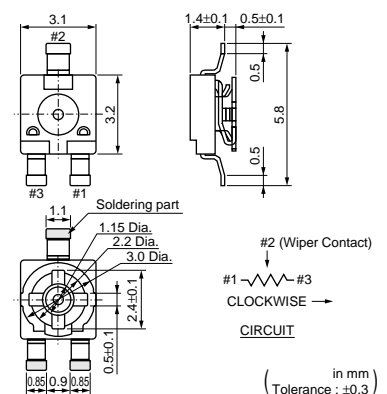

Part Number	Power Rating	Soldering Method	Number of Turns (Effective Rotation Angle)	Total Resistance Value	TCR
PVZ3A201□	0.1W(50°C)	Reflow/Soldering Iron	1(230°±10°)	200ohm ±30%	±500ppm/°C
PVZ3A301□	0.1W(50°C)	Reflow/Soldering Iron	1(230°±10°)	300ohm ±30%	±500ppm/°C
PVZ3A501□	0.1W(50°C)	Reflow/Soldering Iron	1(230°±10°)	500ohm ±30%	±500ppm/°C
PVZ3A102□	0.1W(50°C)	Reflow/Soldering Iron	1(230°±10°)	1k ohm ±30%	±500ppm/°C
PVZ3A202□	0.1W(50°C)	Reflow/Soldering Iron	1(230°±10°)	2k ohm ±30%	±500ppm/°C
PVZ3A302□	0.1W(50°C)	Reflow/Soldering Iron	1(230°±10°)	3k ohm ±30%	±500ppm/°C
PVZ3A502□	0.1W(50°C)	Reflow/Soldering Iron	1(230°±10°)	5k ohm ±30%	±500ppm/°C
PVZ3A103□	0.1W(50°C)	Reflow/Soldering Iron	1(230°±10°)	10k ohm ±30%	±500ppm/°C
PVZ3A203□	0.1W(50°C)	Reflow/Soldering Iron	1(230°±10°)	20k ohm ±30%	±500ppm/°C
PVZ3A303□	0.1W(50°C)	Reflow/Soldering Iron	1(230°±10°)	30k ohm ±30%	±500ppm/°C

Continued on the following page.

Continued from the preceding page.

Part Number	Power Rating	Soldering Method	Number of Turns (Effective Rotation Angle)	Total Resistance Value	TCR
PVZ3A503□	0.1W(50°C)	Reflow/Soldering Iron	1(230°±10°)	50k ohm ±30%	±500ppm/°C
PVZ3A104□	0.1W(50°C)	Reflow/Soldering Iron	1(230°±10°)	100k ohm ±30%	±500ppm/°C
PVZ3A204□	0.1W(50°C)	Reflow/Soldering Iron	1(230°±10°)	200k ohm ±30%	±500ppm/°C
PVZ3A304□	0.1W(50°C)	Reflow/Soldering Iron	1(230°±10°)	300k ohm ±30%	±500ppm/°C
PVZ3A504□	0.1W(50°C)	Reflow/Soldering Iron	1(230°±10°)	500k ohm ±30%	±500ppm/°C
PVZ3A105□	0.1W(50°C)	Reflow/Soldering Iron	1(230°±10°)	1M ohm ±30%	±500ppm/°C
PVZ3A205□	0.1W(50°C)	Reflow/Soldering Iron	1(230°±10°)	2M ohm ±30%	±500ppm/°C
PVZ3K201E01	0.1W(50°C)	Reflow/Soldering Iron	1(230°±10°)	200ohm ±30%	±500ppm/°C
PVZ3K301E01	0.1W(50°C)	Reflow/Soldering Iron	1(230°±10°)	300ohm ±30%	±500ppm/°C
PVZ3K501E01	0.1W(50°C)	Reflow/Soldering Iron	1(230°±10°)	500ohm ±30%	±500ppm/°C
PVZ3K102E01	0.1W(50°C)	Reflow/Soldering Iron	1(230°±10°)	1k ohm ±30%	±500ppm/°C
PVZ3K202E01	0.1W(50°C)	Reflow/Soldering Iron	1(230°±10°)	2k ohm ±30%	±500ppm/°C
PVZ3K302E01	0.1W(50°C)	Reflow/Soldering Iron	1(230°±10°)	3k ohm ±30%	±500ppm/°C
PVZ3K502E01	0.1W(50°C)	Reflow/Soldering Iron	1(230°±10°)	5k ohm ±30%	±500ppm/°C
PVZ3K103E01	0.1W(50°C)	Reflow/Soldering Iron	1(230°±10°)	10k ohm ±30%	±500ppm/°C
PVZ3K203E01	0.1W(50°C)	Reflow/Soldering Iron	1(230°±10°)	20k ohm ±30%	±500ppm/°C
PVZ3K303E01	0.1W(50°C)	Reflow/Soldering Iron	1(230°±10°)	30k ohm ±30%	±500ppm/°C
PVZ3K503E01	0.1W(50°C)	Reflow/Soldering Iron	1(230°±10°)	50k ohm ±30%	±500ppm/°C
PVZ3K104E01	0.1W(50°C)	Reflow/Soldering Iron	1(230°±10°)	100k ohm ±30%	±500ppm/°C
PVZ3K204E01	0.1W(50°C)	Reflow/Soldering Iron	1(230°±10°)	200k ohm ±30%	±500ppm/°C
PVZ3K304E01	0.1W(50°C)	Reflow/Soldering Iron	1(230°±10°)	300k ohm ±30%	±500ppm/°C
PVZ3K504E01	0.1W(50°C)	Reflow/Soldering Iron	1(230°±10°)	500k ohm ±30%	±500ppm/°C
PVZ3K105E01	0.1W(50°C)	Reflow/Soldering Iron	1(230°±10°)	1M ohm ±30%	±500ppm/°C
PVZ3K205E01	0.1W(50°C)	Reflow/Soldering Iron	1(230°±10°)	2M ohm ±30%	±500ppm/°C
PVZ3R201E01	0.1W(50°C)	Reflow/Soldering Iron	1(230°±10°)	200ohm ±30%	±500ppm/°C
PVZ3R301E01	0.1W(50°C)	Reflow/Soldering Iron	1(230°±10°)	300ohm ±30%	±500ppm/°C
PVZ3R501E01	0.1W(50°C)	Reflow/Soldering Iron	1(230°±10°)	500ohm ±30%	±500ppm/°C
PVZ3R102E01	0.1W(50°C)	Reflow/Soldering Iron	1(230°±10°)	1k ohm ±30%	±500ppm/°C
PVZ3R202E01	0.1W(50°C)	Reflow/Soldering Iron	1(230°±10°)	2k ohm ±30%	±500ppm/°C
PVZ3R302E01	0.1W(50°C)	Reflow/Soldering Iron	1(230°±10°)	3k ohm ±30%	±500ppm/°C
PVZ3R502E01	0.1W(50°C)	Reflow/Soldering Iron	1(230°±10°)	5k ohm ±30%	±500ppm/°C
PVZ3R103E01	0.1W(50°C)	Reflow/Soldering Iron	1(230°±10°)	10k ohm ±30%	±500ppm/°C
PVZ3R203E01	0.1W(50°C)	Reflow/Soldering Iron	1(230°±10°)	20k ohm ±30%	±500ppm/°C
PVZ3R303E01	0.1W(50°C)	Reflow/Soldering Iron	1(230°±10°)	30k ohm ±30%	±500ppm/°C
PVZ3R503E01	0.1W(50°C)	Reflow/Soldering Iron	1(230°±10°)	50k ohm ±30%	±500ppm/°C
PVZ3R104E01	0.1W(50°C)	Reflow/Soldering Iron	1(230°±10°)	100k ohm ±30%	±500ppm/°C
PVZ3R204E01	0.1W(50°C)	Reflow/Soldering Iron	1(230°±10°)	200k ohm ±30%	±500ppm/°C
PVZ3R304E01	0.1W(50°C)	Reflow/Soldering Iron	1(230°±10°)	300k ohm ±30%	±500ppm/°C
PVZ3R504E01	0.1W(50°C)	Reflow/Soldering Iron	1(230°±10°)	500k ohm ±30%	±500ppm/°C
PVZ3R105E01	0.1W(50°C)	Reflow/Soldering Iron	1(230°±10°)	1M ohm ±30%	±500ppm/°C
PVZ3R205E01	0.1W(50°C)	Reflow/Soldering Iron	1(230°±10°)	2M ohm ±30%	±500ppm/°C

The blank column is filled with the code of individual specification A01 (standard type) and C01 (high-heat resistance type).

■ Construction



■ Standard Land Pattern

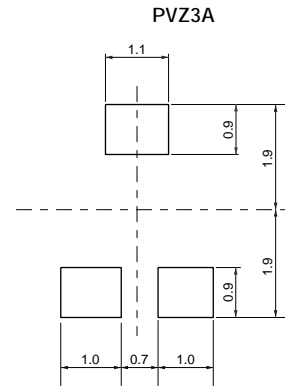

(Tolerance : ±0.1)  
in mm

■ Construction

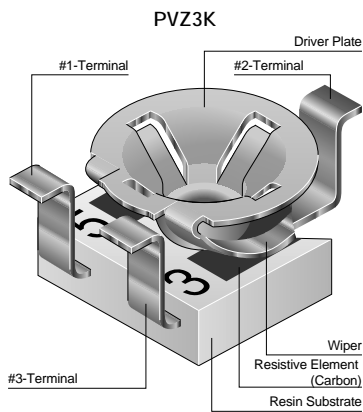

■ Standard Land Pattern

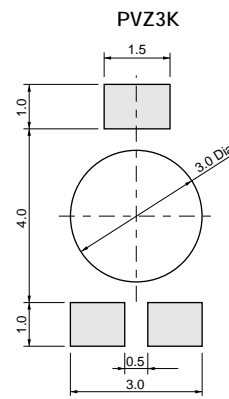

(Tolerance : ±0.1)  
in mm

■ Construction

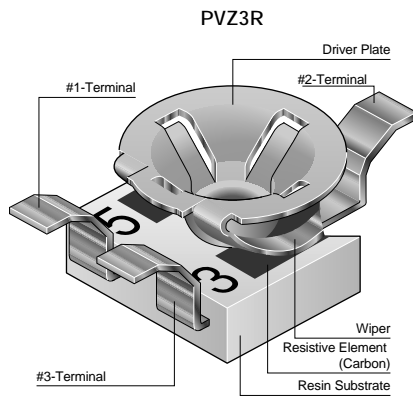

■ Standard Land Pattern

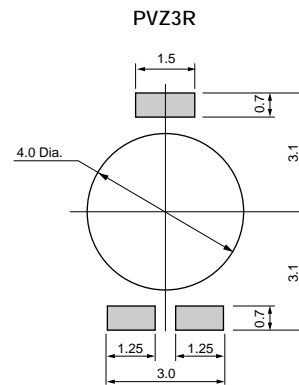

(Tolerance : ±0.1)  
in mm

■ Characteristics

Humidity Exposure	Res. Change : +10, -2%
High Temperature Exposure	Res. Change : $R \leq 100\text{kohm} \dots +2, -10\%$ $100\text{kohm} < R \dots +2, -15\%$
Humidity Load Life	Res. Change : ±10%
Load Life	Res. Change : $R \leq 100\text{kohm} \dots +2, -10\%$ $100\text{kohm} < R \dots +2, -15\%$
Temperature Cycle	Res. Change : ±5%
Temperature Coefficient of Resistance	±500ppm/°C
Rotational Life	Res. Change : ±10% (10 cycles)

## PVS3 Series

### ■ Features

1. Funnel shaped slot allows for in-process automatic adjustment and it provides superior adjustability.
2. Easy insertion and operation of adjustment screwdriver
3. Low profile of 1.5mm height with stopper
4. Plated termination achieves high resistance to solder leaching.
5. Screwdrivers for adjustment are available on the market.

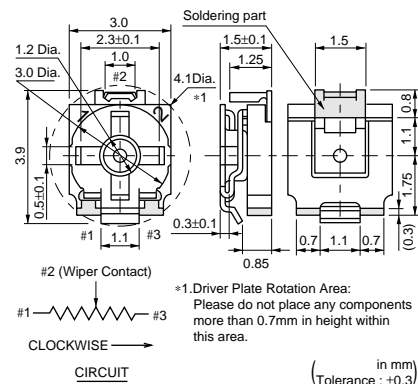

### ■ Applications

1. Camcorders
2. Video disk players
3. TFT-LCD TV sets
4. Headphone stereos
5. Cordless telephones
6. Micro-motors
7. Optical cameras

Part Number	Power Rating	Soldering Method	Number of Turns (Effective Rotation Angle)	Total Resistance Value	TCR
PVS3A101A01	0.1W(70°C)	Reflow/Soldering Iron	1(270°±10°)	100ohm ±25%	±250ppm/°C
PVS3A201A01	0.1W(70°C)	Reflow/Soldering Iron	1(270°±10°)	200ohm ±25%	±250ppm/°C
PVS3A301A01	0.1W(70°C)	Reflow/Soldering Iron	1(270°±10°)	300ohm ±25%	±250ppm/°C
PVS3A501A01	0.1W(70°C)	Reflow/Soldering Iron	1(270°±10°)	500ohm ±25%	±250ppm/°C
PVS3A102A01	0.1W(70°C)	Reflow/Soldering Iron	1(270°±10°)	1k ohm ±25%	±250ppm/°C
PVS3A202A01	0.1W(70°C)	Reflow/Soldering Iron	1(270°±10°)	2k ohm ±25%	±250ppm/°C
PVS3A302A01	0.1W(70°C)	Reflow/Soldering Iron	1(270°±10°)	3k ohm ±25%	±250ppm/°C
PVS3A502A01	0.1W(70°C)	Reflow/Soldering Iron	1(270°±10°)	5k ohm ±25%	±250ppm/°C
PVS3A103A01	0.1W(70°C)	Reflow/Soldering Iron	1(270°±10°)	10k ohm ±25%	±250ppm/°C
PVS3A203A01	0.1W(70°C)	Reflow/Soldering Iron	1(270°±10°)	20k ohm ±25%	±250ppm/°C
PVS3A303A01	0.1W(70°C)	Reflow/Soldering Iron	1(270°±10°)	30k ohm ±25%	±250ppm/°C
PVS3A503A01	0.1W(70°C)	Reflow/Soldering Iron	1(270°±10°)	50k ohm ±25%	±250ppm/°C
PVS3A104A01	0.1W(70°C)	Reflow/Soldering Iron	1(270°±10°)	100k ohm ±25%	±250ppm/°C
PVS3A204A01	0.1W(70°C)	Reflow/Soldering Iron	1(270°±10°)	200k ohm ±25%	±250ppm/°C
PVS3A304A01	0.1W(70°C)	Reflow/Soldering Iron	1(270°±10°)	300k ohm ±25%	±250ppm/°C
PVS3A504A01	0.1W(70°C)	Reflow/Soldering Iron	1(270°±10°)	500k ohm ±25%	±250ppm/°C
PVS3A105A01	0.1W(70°C)	Reflow/Soldering Iron	1(270°±10°)	1M ohm ±25%	±250ppm/°C
PVS3A205A01	0.1W(70°C)	Reflow/Soldering Iron	1(270°±10°)	2M ohm ±25%	±250ppm/°C

### ■ Construction

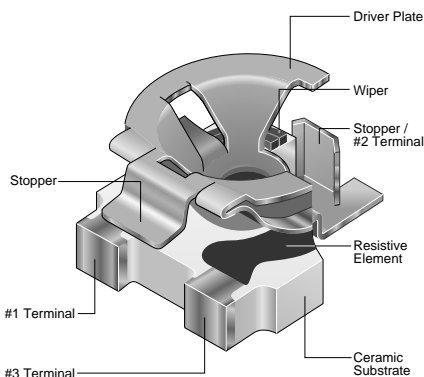

### ■ Standard Land Pattern

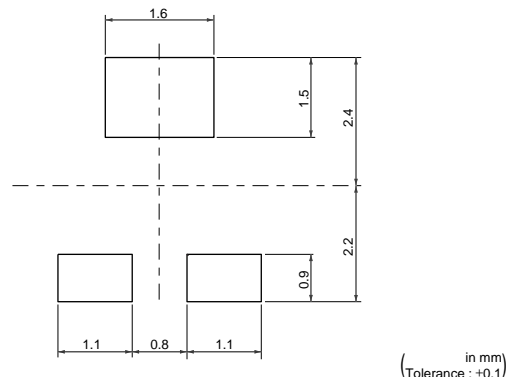

Continued on the following page. ↗

↳ Continued from the preceding page.

### ■ Characteristics

Humidity Exposure	Res. Change : $\pm 3\%$
High Temperature Exposure	Res. Change : $\pm 3\%$
Humidity Load Life	Res. Change : $\pm 3\%$
Load Life	Res. Change : $\pm 3\%$
Temperature Cycle	Res. Change : $\pm 3\%$
Temperature Coefficient of Resistance	$\pm 250\text{ppm}/^\circ\text{C}$
Rotational Life	Res. Change : $\pm 10\%$ (10 cycles)

## PVA3 Series

### ■ Features

1. Funnel shaped slot allows for in-process automatic adjustment and it provides superior adjustability.
2. Easy insertion and operation of adjustment screwdriver
3. Plated termination achieves high resistance to solder leaching.
4. Screwdrivers for adjustment are available on the market.
5. Recommended for both reflow and flow soldering method. (Need cleaning for flow soldering method)

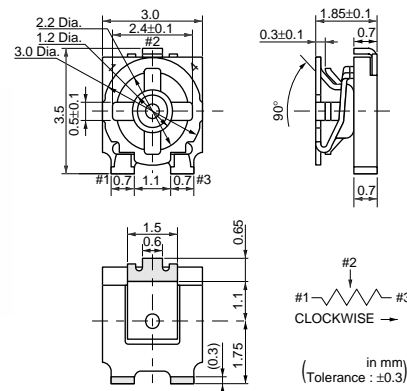

### ■ Applications

1. Camcorders
2. Video disk players
3. TFT-LCD TV sets
4. Headphone stereos
5. Cordless telephones
6. Micro-motors
7. Optical cameras

Part Number	Power Rating	Soldering Method	Number of Turns (Effective Rotation Angle)	Total Resistance Value	TCR
PVA3A101A01	0.1W(70°C)	Flow/Reflow/Soldering Iron	1(270°±10°)	100ohm ±25%	±250ppm/°C
PVA3A201A01	0.1W(70°C)	Flow/Reflow/Soldering Iron	1(270°±10°)	200ohm ±25%	±250ppm/°C
PVA3A301A01	0.1W(70°C)	Flow/Reflow/Soldering Iron	1(270°±10°)	300ohm ±25%	±250ppm/°C
PVA3A501A01	0.1W(70°C)	Flow/Reflow/Soldering Iron	1(270°±10°)	500ohm ±25%	±250ppm/°C
PVA3A102A01	0.1W(70°C)	Flow/Reflow/Soldering Iron	1(270°±10°)	1k ohm ±25%	±250ppm/°C
PVA3A202A01	0.1W(70°C)	Flow/Reflow/Soldering Iron	1(270°±10°)	2k ohm ±25%	±250ppm/°C
PVA3A302A01	0.1W(70°C)	Flow/Reflow/Soldering Iron	1(270°±10°)	3k ohm ±25%	±250ppm/°C
PVA3A502A01	0.1W(70°C)	Flow/Reflow/Soldering Iron	1(270°±10°)	5k ohm ±25%	±250ppm/°C
PVA3A103A01	0.1W(70°C)	Flow/Reflow/Soldering Iron	1(270°±10°)	10k ohm ±25%	±250ppm/°C
PVA3A203A01	0.1W(70°C)	Flow/Reflow/Soldering Iron	1(270°±10°)	20k ohm ±25%	±250ppm/°C
PVA3A303A01	0.1W(70°C)	Flow/Reflow/Soldering Iron	1(270°±10°)	30k ohm ±25%	±250ppm/°C
PVA3A503A01	0.1W(70°C)	Flow/Reflow/Soldering Iron	1(270°±10°)	50k ohm ±25%	±250ppm/°C
PVA3A104A01	0.1W(70°C)	Flow/Reflow/Soldering Iron	1(270°±10°)	100k ohm ±25%	±250ppm/°C
PVA3A204A01	0.1W(70°C)	Flow/Reflow/Soldering Iron	1(270°±10°)	200k ohm ±25%	±250ppm/°C
PVA3A304A01	0.1W(70°C)	Flow/Reflow/Soldering Iron	1(270°±10°)	300k ohm ±25%	±250ppm/°C
PVA3A504A01	0.1W(70°C)	Flow/Reflow/Soldering Iron	1(270°±10°)	500k ohm ±25%	±250ppm/°C
PVA3A105A01	0.1W(70°C)	Flow/Reflow/Soldering Iron	1(270°±10°)	1M ohm ±25%	±250ppm/°C
PVA3A205A01	0.1W(70°C)	Flow/Reflow/Soldering Iron	1(270°±10°)	2M ohm ±25%	±250ppm/°C

### ■ Construction

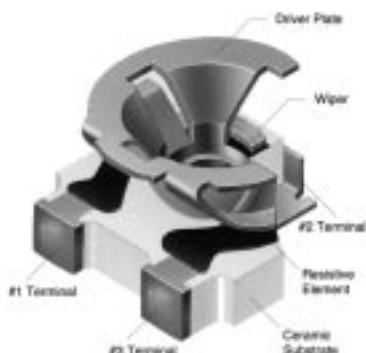

### ■ Standard Land Pattern

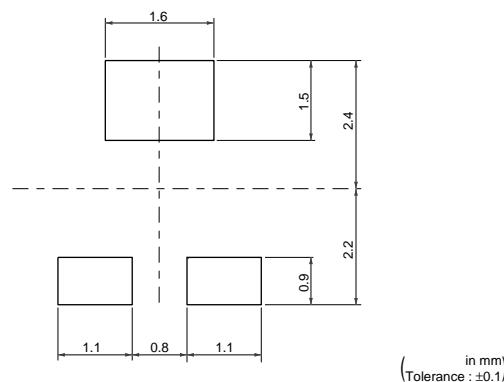

Continued on the following page.

☐ Continued from the preceding page.

### ■ Characteristics

Humidity Exposure	Res. Change : $\pm 3\%$
High Temperature Exposure	Res. Change : $\pm 3\%$
Humidity Load Life	Res. Change : $\pm 3\%$
Load Life	Res. Change : $\pm 3\%$
Temperature Cycle	Res. Change : $\pm 3\%$
Temperature Coefficient of Resistance	$\pm 250\text{ppm}/^\circ\text{C}$
Rotational Life	Res. Change : $\pm 10\%$ (10 cycles)



## PVZ3/PVS3/PVA3 Series Notice

2

### ■ Notice (Operating and Storage Conditions)

1. Store in temperatures of -10 to +40 deg. C and relative humidity of 30-85%RH.
2. Do not store in or near corrosive gases.
3. Use within six months after delivery.
4. Open the package just before using.
5. Do not store under direct sunlight.
6. If you use the trimmer potentiometer in an environment other than listed below, please consult with a Murata factory representative prior to using.  
The trimmer potentiometer should not be used under

- the following environmental conditions:
- (1) Corrosive gaseous atmosphere  
(Ex. Chlorine gas, Hydrogen sulfide gas, Ammonia gas, Sulfuric acid gas, Nitric oxide gas, etc.)
  - (2) In liquid  
(Ex. Oil, Medical liquid, Organic solvent, etc.)
  - (3) Dusty / dirty atmosphere
  - (4) Direct sunlight
  - (5) Static voltage nor electric/magnetic fields
  - (6) Direct sea breeze
  - (7) Other variations of the above

### ■ Notice (Rating)

1. When using with partial load (rheostat), minimize the power depending on the resistance value.
2. The maximum input voltage to a trimmer potentiometer should not exceed  $(P.R)^{1/2}$  or the maximum operating voltage, whichever is smaller.
3. The maximum input current to a trimmer potentiometer should not exceed  $(P/R)^{1/2}$  or the allowable wiper current, whichever is smaller.
4. If the trimmer potentiometer is used in DC and high humidity conditions, please connect wiper (#2) for plus and resistive element (#1 or #3) for minus.  
(PVZ3 Series only)

### ■ Notice (Soldering and Mounting)

1. Soldering
    - (1) Standard soldering condition
      - (a) Reflow soldering :  
Refer to the standard temperature profile.
      - (b) Soldering iron:  
\*PVZ3A\_A01 series  
>Temperature of tip 260 deg. C max.  
>Soldering time 3 sec. max.  
>Diameter 2mm max.  
>Wattage of iron 30W max.  
\*PVZ3A\_C01, PVZ3K\_E01, PVZ3R\_E01 series  
\*PVS3, PVA3 series  
>Temperature of tip 360 deg. C max.  
>Soldering time 3 sec. max.  
>Diameter 2mm max.  
>Wattage of iron 30W max.
- Before using other soldering conditions than those listed above, please consult with Murata factory representative prior to using. If the soldering conditions are not suitable, e.g., excessive time and/or excessive temperature, the trimmer potentiometer may deviate from the specified characteristics.
- (2) Flow soldering is available for PVA3 series.  
For PVZ3 and PVS3, do not use flow soldering method (dipping).

- If you use the flow soldering method, the trimmer potentiometer may not function.
- (3) The soldering iron should not come in contact with the case of the trimmer potentiometer. If such contact does occur, the trimmer potentiometer may be damaged.
  - (4) Apply the appropriate amount of solder paste.  
The thickness of solder paste should be printed from 150 micro m to 200 micro m (PVZ3 series should be printed from 100 micro m to 150 micro m) and the dimension of land pattern used should be Murata's standard land pattern at reflow soldering. Insufficient amounts of solder can lead to insufficient soldering strength on PCB. Excessive amounts of solder may cause bridging between the terminals.
2. Mounting
    - (1) Use our standard land dimension. Excessive land area causes displacement due to the effect of the surface tension of the solder. Insufficient land area leads to insufficient soldering strength of the chip.
    - (2) Do not apply excessive force (preferably 4.9N (Ref.; 500gf) max.), when the trimmer potentiometer is mounted to the PCB.
    - (3) Do not warp and/or bend PC board to prevent

Continued on the following page. 

## PVZ3/PVS3/PVA3 Series Notice

Continued from the preceding page.

trimmer potentiometer from breakage.

- (4) In chip placers, the recommended size of the cylindrical pick-up nozzle should be outer dimension 2.5-2.8mm dia. and inner dimension 2mm dia.

### 3. Cleaning

- (1) In case there is flux on the resistive element,

clean sufficiently with cleaning solvents and completely remove all residual flux.

- (2) Isopropyl-alcohol and Ethyl-alcohol are applicable solvents for cleaning. If you use any other types of solvents, please evaluate performance by your product.

### Flow Soldering Standard Profile

PVA3 Series Only

For flow soldering

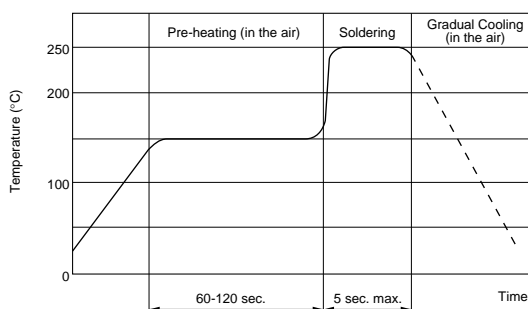

### Reflow Soldering Standard Profile

PVA3/PVS3/PVZ3\_A01 Series

For reflow soldering

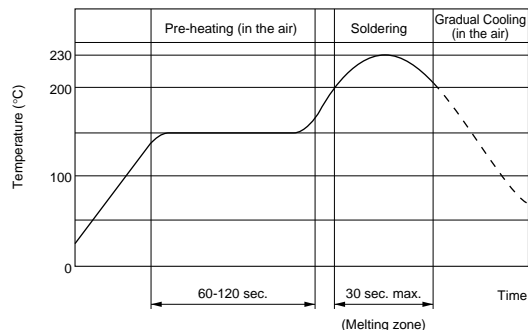

PVZ3\_C01/E01 Series

For reflow soldering

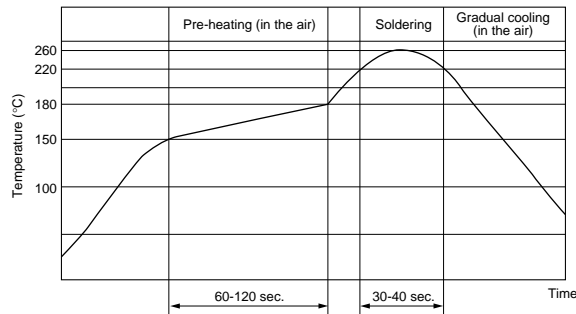

### Notice (Handling)

- Use suitable screwdrivers that fit comfortably in driver slot. We recommend the screwdrivers below.
  - \* Recommended screwdriver for manual adjustment <PVZ3/PVA3 series>  
VESSEL MFG. : NO.9000+1.7x30  
(Murata P/N : KMDR080)
  - <PVZ3/PVA3/PVS3 series>  
TORAY MFG. : SA-2225  
(Murata P/N : KMDR070)
  - \* Recommended screwdriver for automatic adjustment  
TORAY MFG. : JB-2225  
(Murata P/N : KMBT070)
- Don't apply more than 4.9N (Ref.; 500gf) of twist

and stress after mounting onto PCB to prevent contact intermittence. If excessive force is applied, the trimmer potentiometer may not function.

- For PVZ3 and PVA3 series, please use within the effective rotational angle.  
The potentiometer does not have a mechanical stop for over rotation. In cases out of effective rotational angle, the trimmer potentiometer may not function.
- When using a lock paint to fix slot position, please consult with a Murata factory representative prior to using to prevent corrosion and contact intermittence.

## PVZ3/PVS3/PVA3 Series Notice

### ■ Notice (Other)

1. Please make sure that your product has been evaluated and confirmed against your specifications when our product is mounted to your product.
2. Murata cannot guarantee trimmer potentiometer integrity when used under conditions other than those specified in this document.

2

# Trimmer Potentiometers



## SMD Sealed Type 2mm Size PVF2 Series

### ■ Features

1. Ultra-compact size of "2x2x2.3mm"
2. A sealed structure prevents liquids (water, cleaning liquid, sweat, etc.) from entering.
3. As for the resistance change characteristics, both a log curve type and linear type are available.
4. A rotation service life of 100 cycles is guaranteed.
5. Can be automatically mounted using a chip placer, as well as mounted using reflow soldering.

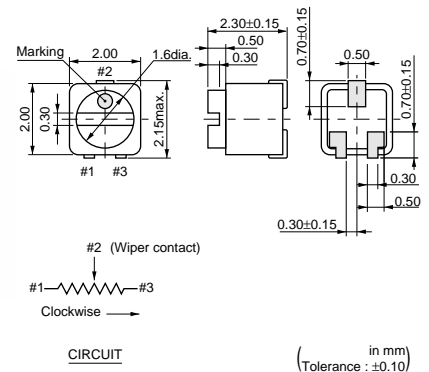

### ■ Applications

1. Hearing aids
2. Ultra-compact sensors or the like
3. Applications requiring ultra-compactness, and a sealed structure

Part Number	Power Rating	Soldering Method	Number of Turns (Effective Rotation Angle)	Total Resistance Value	TCR
PVF2A501A11	0.001W(50°C)	Reflow/Soldering Iron	1(210°±10°)	500ohm ±30%	±500ppm/°C
PVF2A102A11	0.001W(50°C)	Reflow/Soldering Iron	1(210°±10°)	1k ohm ±30%	±500ppm/°C
PVF2A202A11	0.001W(50°C)	Reflow/Soldering Iron	1(210°±10°)	2k ohm ±30%	±500ppm/°C
PVF2A502A11	0.001W(50°C)	Reflow/Soldering Iron	1(210°±10°)	5k ohm ±30%	±500ppm/°C
PVF2A103A11	0.001W(50°C)	Reflow/Soldering Iron	1(210°±10°)	10k ohm ±30%	±500ppm/°C
PVF2A203A11	0.001W(50°C)	Reflow/Soldering Iron	1(210°±10°)	20k ohm ±30%	±500ppm/°C
PVF2A503A11	0.001W(50°C)	Reflow/Soldering Iron	1(210°±10°)	50k ohm ±30%	±500ppm/°C
PVF2A104A11	0.001W(50°C)	Reflow/Soldering Iron	1(210°±10°)	100k ohm ±30%	±500ppm/°C
PVF2A204A11	0.001W(50°C)	Reflow/Soldering Iron	1(210°±10°)	200k ohm ±30%	±500ppm/°C
PVF2A504A11	0.001W(50°C)	Reflow/Soldering Iron	1(210°±10°)	500k ohm ±30%	±500ppm/°C
PVF2A105A11	0.001W(50°C)	Reflow/Soldering Iron	1(210°±10°)	1M ohm ±30%	±500ppm/°C
PVF2A102A41	0.001W(50°C)	Reflow/Soldering Iron	1(210°±10°)	1k ohm ±30%	±500ppm/°C
PVF2A202A41	0.001W(50°C)	Reflow/Soldering Iron	1(210°±10°)	2k ohm ±30%	±500ppm/°C
PVF2A502A41	0.001W(50°C)	Reflow/Soldering Iron	1(210°±10°)	5k ohm ±30%	±500ppm/°C
PVF2A103A41	0.001W(50°C)	Reflow/Soldering Iron	1(210°±10°)	10k ohm ±30%	±500ppm/°C
PVF2A203A41	0.001W(50°C)	Reflow/Soldering Iron	1(210°±10°)	20k ohm ±30%	±500ppm/°C
PVF2A503A41	0.001W(50°C)	Reflow/Soldering Iron	1(210°±10°)	50k ohm ±30%	±500ppm/°C
PVF2A104A41	0.001W(50°C)	Reflow/Soldering Iron	1(210°±10°)	100k ohm ±30%	±500ppm/°C
PVF2A204A41	0.001W(50°C)	Reflow/Soldering Iron	1(210°±10°)	200k ohm ±30%	±500ppm/°C
PVF2A504A41	0.001W(50°C)	Reflow/Soldering Iron	1(210°±10°)	500k ohm ±30%	±500ppm/°C
PVF2A102A51	0.001W(50°C)	Reflow/Soldering Iron	1(210°±10°)	1k ohm ±30%	±500ppm/°C
PVF2A202A51	0.001W(50°C)	Reflow/Soldering Iron	1(210°±10°)	2k ohm ±30%	±500ppm/°C
PVF2A502A51	0.001W(50°C)	Reflow/Soldering Iron	1(210°±10°)	5k ohm ±30%	±500ppm/°C
PVF2A103A51	0.001W(50°C)	Reflow/Soldering Iron	1(210°±10°)	10k ohm ±30%	±500ppm/°C
PVF2A203A51	0.001W(50°C)	Reflow/Soldering Iron	1(210°±10°)	20k ohm ±30%	±500ppm/°C
PVF2A503A51	0.001W(50°C)	Reflow/Soldering Iron	1(210°±10°)	50k ohm ±30%	±500ppm/°C
PVF2A104A51	0.001W(50°C)	Reflow/Soldering Iron	1(210°±10°)	100k ohm ±30%	±500ppm/°C
PVF2A204A51	0.001W(50°C)	Reflow/Soldering Iron	1(210°±10°)	200k ohm ±30%	±500ppm/°C
PVF2A504A51	0.001W(50°C)	Reflow/Soldering Iron	1(210°±10°)	500k ohm ±30%	±500ppm/°C
PVF2A102A81	0.001W(50°C)	Reflow/Soldering Iron	1(210°±10°)	1k ohm ±30%	±500ppm/°C
PVF2A202A81	0.001W(50°C)	Reflow/Soldering Iron	1(210°±10°)	2k ohm ±30%	±500ppm/°C
PVF2A502A81	0.001W(50°C)	Reflow/Soldering Iron	1(210°±10°)	5k ohm ±30%	±500ppm/°C
PVF2A103A81	0.001W(50°C)	Reflow/Soldering Iron	1(210°±10°)	10k ohm ±30%	±500ppm/°C
PVF2A203A81	0.001W(50°C)	Reflow/Soldering Iron	1(210°±10°)	20k ohm ±30%	±500ppm/°C

Continued on the following page.

Continued from the preceding page.

Part Number	Power Rating	Soldering Method	Number of Turns (Effective Rotation Angle)	Total Resistance Value	TCR
PVF2A503A81	0.001W(50°C)	Reflow/Soldering Iron	1(210°±10°)	50k ohm ±30%	±500ppm/°C
PVF2A104A81	0.001W(50°C)	Reflow/Soldering Iron	1(210°±10°)	100k ohm ±30%	±500ppm/°C
PVF2A204A81	0.001W(50°C)	Reflow/Soldering Iron	1(210°±10°)	200k ohm ±30%	±500ppm/°C
PVF2A504A81	0.001W(50°C)	Reflow/Soldering Iron	1(210°±10°)	500k ohm ±30%	±500ppm/°C
PVF2A102A91	0.001W(50°C)	Reflow/Soldering Iron	1(210°±10°)	1k ohm ±30%	±500ppm/°C
PVF2A202A91	0.001W(50°C)	Reflow/Soldering Iron	1(210°±10°)	2k ohm ±30%	±500ppm/°C
PVF2A502A91	0.001W(50°C)	Reflow/Soldering Iron	1(210°±10°)	5k ohm ±30%	±500ppm/°C
PVF2A103A91	0.001W(50°C)	Reflow/Soldering Iron	1(210°±10°)	10k ohm ±30%	±500ppm/°C
PVF2A203A91	0.001W(50°C)	Reflow/Soldering Iron	1(210°±10°)	20k ohm ±30%	±500ppm/°C
PVF2A503A91	0.001W(50°C)	Reflow/Soldering Iron	1(210°±10°)	50k ohm ±30%	±500ppm/°C
PVF2A104A91	0.001W(50°C)	Reflow/Soldering Iron	1(210°±10°)	100k ohm ±30%	±500ppm/°C
PVF2A204A91	0.001W(50°C)	Reflow/Soldering Iron	1(210°±10°)	200k ohm ±30%	±500ppm/°C
PVF2A504A91	0.001W(50°C)	Reflow/Soldering Iron	1(210°±10°)	500k ohm ±30%	±500ppm/°C

The last three digits express the individual specification codes for Resistant Curve. Please refer to Resistance Curve on the following page for characteristics.

### Construction

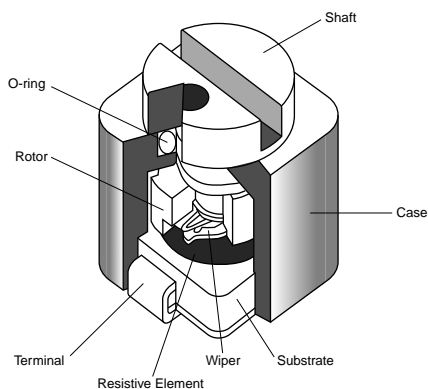

### Standard Land Pattern

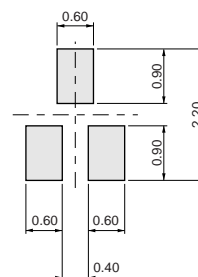

(Tolerance : ±0.10)

### Characteristics

Temperature Cycle	ΔTR ±5%
Humidity	ΔTR ±15, -2%
Vibration	ΔV.S.S. ±5%
Shock (100G)	ΔV.S.S. ±5%
Temperature Load Life	ΔTR +2, -10%
Low Temperature Exposure	ΔTR ±3%
Rotational Life (100 cycles)	ΔTR ±10%

ΔTR: Total Resistance Change  
 ΔV.S.S.: Voltage Setting Stability

### Resistance Curve

Linear-log. curve (Measured from terminal 1 to 2)

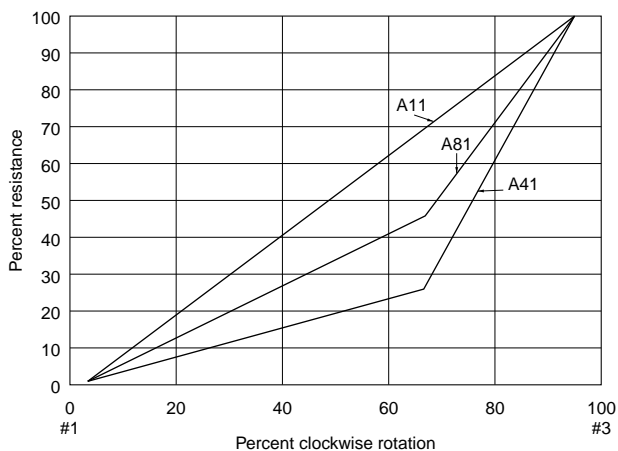

Linear-log. log. curve (Measured from terminal 2 to 3)

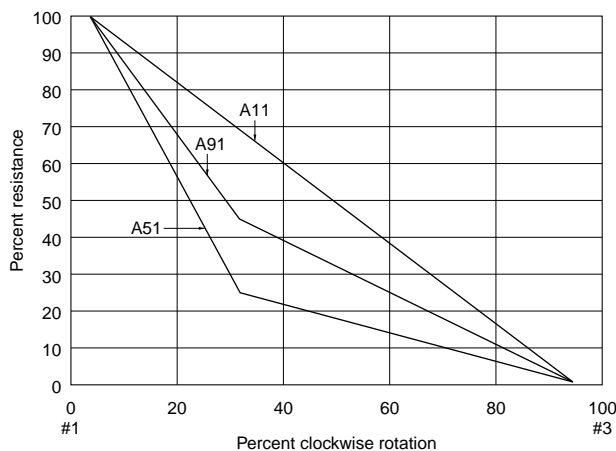

## PVF2 Series Notice

### ■ Notice (Operating and Storage Conditions)

1. Store in temperatures of -10 to +40 deg. C and relative humidity of 30-85%RH.
2. Do not store in or near corrosive gases.
3. Use within six months after delivery.
4. Open the package just before using.
5. Do not store under direct sunlight.
6. If you use the trimmer potentiometer in an environment other than listed below, please consult with a Murata factory representative prior to using.  
The trimmer potentiometer should not be used under

- the following environmental conditions:
- (1) Corrosive gaseous atmosphere  
(Ex. Chlorine gas, Hydrogen sulfide gas, Ammonia gas, Sulfuric acid gas, Nitric oxide gas, etc.)
  - (2) In liquid  
(Ex. Oil, Medical liquid, Organic solvent, etc.)
  - (3) Dusty / dirty atmosphere
  - (4) Direct sunlight
  - (5) Static voltage nor electric/magnetic fields
  - (6) Direct sea breeze
  - (7) Other variations of the above

### ■ Notice (Rating)

1. When using with partial load (rheostat), minimize the power depending on the resistance value.
2. The maximum input voltage to a trimmer potentiometer should not exceed  $(P.R)^{1/2}$  or the maximum operating voltage, whichever is smaller.
3. The maximum input current to a trimmer potentiometer should not exceed  $(P/R)^{1/2}$  or the allowable wiper current, whichever is smaller.
4. If the trimmer potentiometer is used in DC and high humidity conditions, please connect wiper (#2) for plus and resistive element (#1 or #3) for minus.

### ■ Notice (Soldering and Mounting)

1. Soldering
    - (1) Standard solder iron condition
      - (a) Reflow soldering:  
Refer to the standard temperature profile.
      - (b) Soldering iron:
        - >Temperature of tip 260 deg. C max.
        - >Soldering time 3 sec. max.
        - >Diameter 1mm dia. max.
        - >Wattage of iron 30W max.
- Before using other soldering conditions than those listed above, please consult with a Murata factory representative prior to using. If the soldering conditions are not suitable, e.g., excessive time and/or excessive temperature, the trimmer potentiometer may deviate from the specified characteristics.
- (2) Use our standard land dimension. Excessive land area causes displacement due to the effect of the surface tension of the solder. Insufficient land area leads to insufficient soldering strength of the chip.
  - (3) The soldering iron should not come in contact with the case of the trimmer potentiometer. If such contact does occur, the trimmer potentiometer may be damaged.
  - (4) Cannot be soldered using the flow soldering method. If you use the flow soldering method,

- the trimmer potentiometer may not function.
2. Mounting
    - (1) Use our standard land dimension. Excessive land area causes displacement due to the effect of the surface tension of the solder. Insufficient land area leads to insufficient soldering strength of the chip.
    - (2) Do not apply excessive force (preferably 4.9N (Ref.; 500gf) max.), when the trimmer potentiometer is mounted to the PCB.
    - (3) Do not warp and/or bend PC board to prevent trimmer potentiometer from breakage.
  3. Cleaning
    - (1) Isopropyl-alcohol and Ethyl-alcohol are applicable solvents for cleaning. If you use any other types of solvents, please consult with a Murata factory representative prior to using.
    - (2) The total cleaning time by cold dipping, vapor and ultrasonic washing (conditions as below) method should be less than 3 minutes.
    - (3) For ultra-sonic cleaning, the available condition is as follows.
      - >Power: 600W (67 liter) max.
      - >Frequency: 28kHz
      - >Temperature: Ambient temperatureDue to the ultra-sonic cleaning equipment's peculiar self-resonance point and that the

Continued on the following page. 

## PVF2 Series Notice

Continued from the preceding page.

cleaning compatibility usually depends on the jig construction and/or the cleaning condition such as the depth of immersion, please check the cleaning equipment to determine the suitable

conditions.

If the trimmer potentiometer is cleaned by other conditions, the trimmer potentiometer may be damaged.

### Reflow Soldering Standard Profile

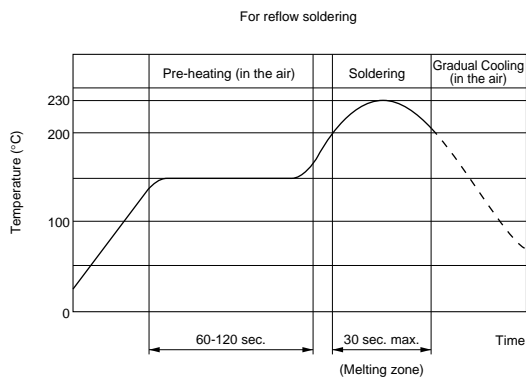

### Notice (Handling)

1. Use suitable screwdrivers that fit comfortably in driver slot.
2. Don't apply more than 4.9N (Ref.; 500gf) of twist and stress after mounting onto PCB to prevent contact intermittence. If excessive force is applied, the trimmer potentiometer may not function.
3. The rotational torque at the position of the adjustment range should not exceed the stop strength.
4. When using a lock paint to fix slot position, please use adhesive resin without chlorine or sulfur (Three-bond "1401 series").

### Notice (Other)

1. Please make sure that your product has been evaluated and confirmed against your specifications when our product is mounted to your product.
2. Murata cannot guarantee trimmer potentiometer integrity when used under conditions other than those specified in this document.

# Trimmer Potentiometers



## SMD Sealed Type 3mm Size PVG3 Series

### ■ Features

1. Sealed construction protects the interior from dust and liquid, which achieves stable performance.
2. Driver plate with cross-slot is suitable for automatic adjustment.
3. Rotor with large diameter and deep groove improves driver insertion.
4. J-hook, Gull wing terminal shape. Rear and through hole terminal shape.
5. 3mm and 4mm land pattern can be used without change. (Gull wing is suitable for 4mm size land pattern.)
6. Heat resistance performance enables high temperature peak re-flow soldering.
7. To be complied with RoHS directive by new Cd free cermet resistive material. Pb free terminals with Sn plating.

### ■ Applications

1. Small sensors
2. Optical Transceiver Module
3. Copier
4. Printer
5. Compact Power Supply
6. Wireless Radio module



PVG3A

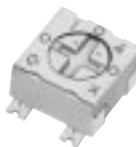
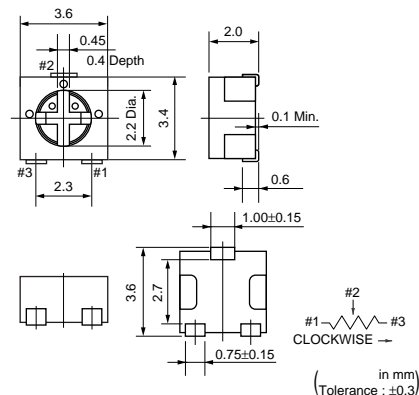

PVG3G

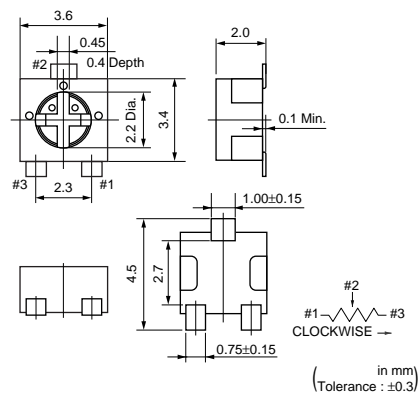

PVG3K

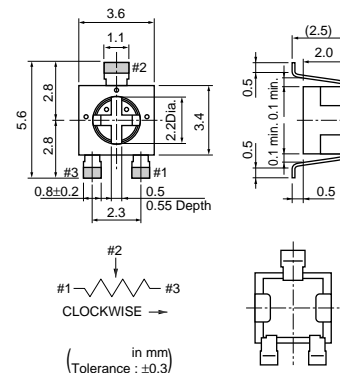

Part Number	Power Rating	Soldering Method	Number of Turns (Effective Rotation Angle)	Total Resistance Value	TCR
PVG3□100C01	0.25W(70°C)	Reflow/Soldering Iron	1(210°±10°)	10ohm ±20%	±150ppm/°C
PVG3□200C01	0.25W(70°C)	Reflow/Soldering Iron	1(210°±10)	20ohm ±20%	±150ppm/°C
PVG3□500C01	0.25W(70°C)	Reflow/Soldering Iron	1(210°±10°)	50ohm ±20%	±150ppm/°C
PVG3□101C01	0.25W(70°C)	Reflow/Soldering Iron	1(210°±10°)	100ohm ±20%	±150ppm/°C
PVG3□201C01	0.25W(70°C)	Reflow/Soldering Iron	1(210°±10°)	200ohm ±20%	±150ppm/°C
PVG3□501C01	0.25W(70°C)	Reflow/Soldering Iron	1(210°±10°)	500ohm ±20%	±150ppm/°C
PVG3□102C01	0.25W(70°C)	Reflow/Soldering Iron	1(210°±10°)	1k ohm ±20%	±150ppm/°C
PVG3□202C01	0.25W(70°C)	Reflow/Soldering Iron	1(210°±10°)	2k ohm ±20%	±150ppm/°C
PVG3□502C01	0.25W(70°C)	Reflow/Soldering Iron	1(210°±10°)	5k ohm ±20%	±150ppm/°C
PVG3□103C01	0.25W(70°C)	Reflow/Soldering Iron	1(210°±10°)	10k ohm ±20%	±150ppm/°C
PVG3□203C01	0.25W(70°C)	Reflow/Soldering Iron	1(210°±10°)	20k ohm ±20%	±150ppm/°C
PVG3□503C01	0.25W(70°C)	Reflow/Soldering Iron	1(210°±10°)	50k ohm ±20%	±150ppm/°C

Continued on the following page.



Continued from the preceding page.

Part Number	Power Rating	Soldering Method	Number of Turns (Effective Rotation Angle)	Total Resistance Value	TCR
PVG3□104C01	0.25W(70°C)	Reflow/Soldering Iron	1(210°±10°)	100k ohm ±20%	±150ppm/°C
PVG3□204C01	0.25W(70°C)	Reflow/Soldering Iron	1(210°±10°)	200k ohm ±20%	±150ppm/°C
PVG3□504C01	0.25W(70°C)	Reflow/Soldering Iron	1(210°±10°)	500k ohm ±20%	±150ppm/°C
PVG3□105C01	0.25W(70°C)	Reflow/Soldering Iron	1(210°±10°)	1M ohm ±20%	±150ppm/°C
PVG3□205C01	0.25W(70°C)	Reflow/Soldering Iron	1(210°±10°)	2M ohm ±20%	±150ppm/°C

The blank column is filled with the code of adjustment direction and lead type A (top, J-hook), G (top, gull-wing), or K (rear).

Part Number	Power Rating (W)	Soldering Method	Number of Turns (Effective Rotation Angle)	Total Resistance Value	TCR (ppm/°C)	Remarks
PVG3□100A01	0.25(70°C)	Reflow/Soldering Iron	1(210°±10°)	10 ohm±20%	±250	Non Standard Product (Cd included)
PVG3□200A01	0.25(70°C)	Reflow/Soldering Iron	1(210°±10°)	20 ohm±20%	±250	
PVG3□500A01	0.25(70°C)	Reflow/Soldering Iron	1(210°±10°)	50 ohm±20%	±250	
PVG3□101A01	0.25(70°C)	Reflow/Soldering Iron	1(210°±10°)	100 ohm±20%	±250	
PVG3□201A01	0.25(70°C)	Reflow/Soldering Iron	1(210°±10°)	200 ohm±20%	±100	
PVG3□501A01	0.25(70°C)	Reflow/Soldering Iron	1(210°±10°)	500 ohm±20%	±100	
PVG3□102A01	0.25(70°C)	Reflow/Soldering Iron	1(210°±10°)	1k ohm±20%	±100	
PVG3□202A01	0.25(70°C)	Reflow/Soldering Iron	1(210°±10°)	2k ohm±20%	±100	
PVG3□502A01	0.25(70°C)	Reflow/Soldering Iron	1(210°±10°)	5k ohm±20%	±100	
PVG3□103A01	0.25(70°C)	Reflow/Soldering Iron	1(210°±10°)	10k ohm±20%	±100	
PVG3□203A01	0.25(70°C)	Reflow/Soldering Iron	1(210°±10°)	20k ohm±20%	±100	
PVG3□503A01	0.25(70°C)	Reflow/Soldering Iron	1(210°±10°)	50k ohm±20%	±100	
PVG3□104A01	0.25(70°C)	Reflow/Soldering Iron	1(210°±10°)	100k ohm±20%	±100	
PVG3□204A01	0.25(70°C)	Reflow/Soldering Iron	1(210°±10°)	200k ohm±20%	±100	
PVG3□504A01	0.25(70°C)	Reflow/Soldering Iron	1(210°±10°)	500k ohm±20%	±100	
PVG3□105A01	0.25(70°C)	Reflow/Soldering Iron	1(210°±10°)	1M ohm±20%	±100	
PVG3□205A01	0.25(70°C)	Reflow/Soldering Iron	1(210°±10°)	2M ohm±20%	±100	

4

Construction

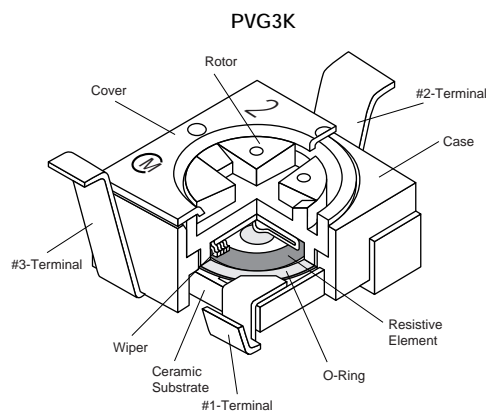
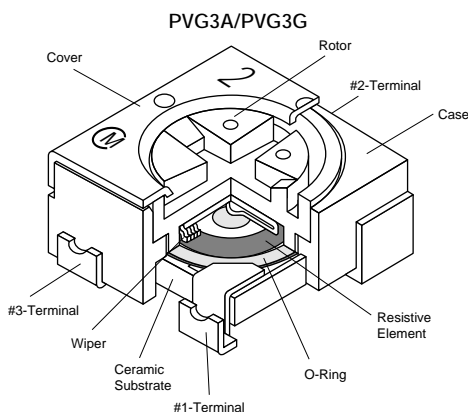

Standard Land Pattern

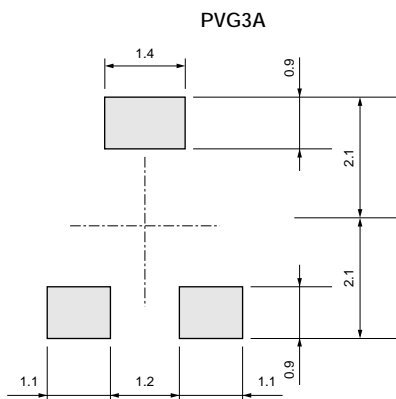

(in mm)  
(Tolerance : ±0.1)

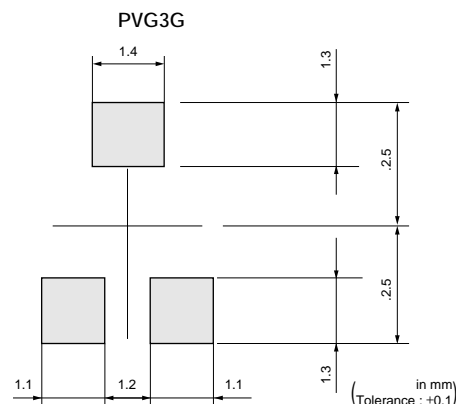

(in mm)  
(Tolerance : ±0.1)

Continued from the preceding page.

## Standard Land Pattern

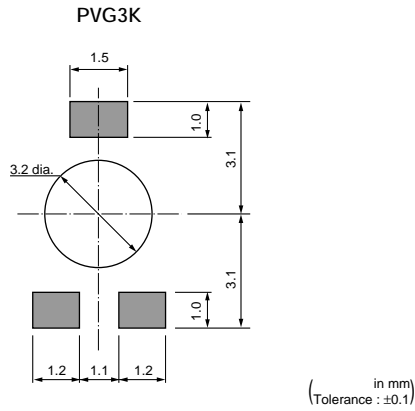

## Characteristics

Temperature Cycle	$\Delta TR$ ±2%
	$\Delta V.S.S$ ±1%
Humidity	$\Delta TR$ ±2%
	$\Delta V.S.S$ ±1%
	IR 10Mohm min.
Vibration (20G)	$\Delta TR$ ±1%
	$\Delta V.S.S$ ±1%
Shock (100G)	$\Delta TR$ ±1%
	$\Delta V.S.S$ ±1%
Temperature Load Life	$\Delta TR$ ±3% or 3ohm max., whichever is greater
	$\Delta V.S.S$ ±1%
Low Temperature Exposure	$\Delta TR$ ±2%
	$\Delta V.S.S$ ±2%
High Temperature Exposure	$\Delta TR$ ±3%
	$\Delta V.S.S$ ±2%
Rotational Life (50cycles)	$\Delta TR$ $R \leq 100\text{ohm} \dots \pm 3\%$ or 2ohm max., whichever is greater
	$R > 100\text{kohm} \dots +0/-10\%$

$\Delta TR$  : Total Resistance Change  
 $\Delta V.S.S$  : Voltage Setting Stability  
 IR : Insulation Resistance  
 R : Standard Total Resistance

## PVG3 Series Notice

### ■ Notice (Operating and Storage Conditions)

1. Store in temperatures of -10 to +40 deg. C and relative humidity of 30-85%RH.
2. Do not store in or near corrosive gases.
3. Use within six months after delivery.
4. Open the package just before using.
5. Do not store under direct sunlight.
6. If you use the trimmer potentiometer in an environment other than listed below, please consult with a Murata factory representative prior to using.  
The trimmer potentiometer should not be used under

- the following environmental conditions:
- (1) Corrosive gaseous atmosphere  
(Ex. Chlorine gas, Hydrogen sulfide gas, Ammonia gas, Sulfuric acid gas, Nitric oxide gas, etc.)
  - (2) In liquid  
(Ex. Oil, Medical liquid, Organic solvent, etc.)
  - (3) Dusty / dirty atmosphere
  - (4) Direct sunlight
  - (5) Static voltage nor electric/magnetic fields
  - (6) Direct sea breeze
  - (7) Other variations of the above

### ■ Notice (Rating)

1. When using with partial load (rheostat), minimize the power depending on the resistance value.
2. The maximum input voltage to a trimmer potentiometer should not exceed  $(P.R)^{1/2}$  or the maximum operating voltage, whichever is smaller.
3. The maximum input current to a trimmer potentiometer should not exceed  $(P/R)^{1/2}$  or the allowable wiper current, whichever is smaller.

### ■ Notice (Soldering and Mounting)

#### 1. Soldering

- (1) Standard soldering condition
  - (a) Reflow soldering :  
Refer to the standard temperature profile.
  - (b) Soldering iron  
Temperature of tip : 400 deg. C max.  
Soldering time : 3 sec. max.  
Diameter of tip : 2mm dia. max.  
Wattage of iron : 30W max.

Before using other soldering conditions more than those listed above, please consult with a Murata factory representative prior to using.  
If the soldering conditions are not suitable, e.g., excessive time and/or excessive temperature, the trimmer potentiometer may deviate from the specified characteristics.

- (2) Cannot be soldered using the flow soldering method. If you use the flow soldering method, the trimmer potentiometer may not function.
- (3) The soldering iron should not come in contact with the case of the trimmer potentiometer. If such contact does occur, the trimmer potentiometer may be damaged.
- (4) Apply the appropriate amount of solder paste.  
If the amount of solder paste applied to the land is insufficient, the required adhesive strength cannot be obtained. If an excessive amount of solder paste is applied, solder bridging or flux overflow to the resistive element surface can occur.

#### 2. Mounting

- (1) Use our standard land dimension. Excessive land area causes displacement due to the effect of the surface tension of the solder. Insufficient land area leads to insufficient soldering strength of the chip.
- (2) Do not apply excessive force (preferably 4.9N (Ref.; 500gf) max.), when the trimmer potentiometer is mounted to the PCB.
- (3) Do not warp and/or bend PC board to prevent trimmer potentiometer from breakage.
- (4) In chip placers, the size of the cylindrical pick-up nozzle should be outer dimension 2.5-3.0mm dia. and inner dimension 2.0-2.5mm dia..

#### 3. Cleaning

- (1) Isopropyl-alcohol and Ethyl-alcohol are applicable solvents for cleaning. If you use any other types of solvents, please consult with a Murata factory representative prior to using.
- (2) Less than 3 minutes of total cleaning time by dipping, vapor and ultra-sonic method.
- (3) In case of ultra-sonic cleaning method, cleaning conditions should be as follows.
  - (a) Power: 600W (67lit.) max.
  - (b) Frequency: 28kHz
  - (c) Temperature: Ambient temperature  
Due to ultra-sonic cleaning equipment's peculiar self-resonance point and that cleaning compatibility usually depends on the jig

Continued on the following page. 

## PVG3 Series Notice

Continued from the preceding page.

construction and/or the cleaning condition such as the depth of immersion, please check the cleaning equipment to determine the suitable

conditions. If the condition is not suitable, the trimmer potentiometer may deviate from specified characteristics.

### Reflow Soldering Standard Profile

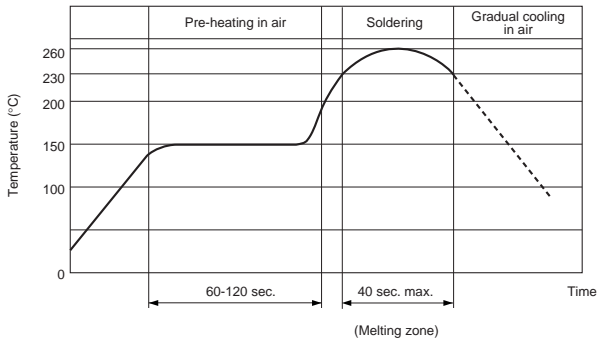

### Notice (Handling)

1. Use suitable screwdrivers that fit comfortably in driver slot.

\* Recommended screwdriver for manual adjustment  
TORAY INDUSTRIES, INC. : SA-2225  
(Murata P/N : KMDR070)

\* Recommended screwdriver bit for automatic adjustment  
TORAY INDUSTRIES, INC. : JB-2225  
(Murata P/N : KMBT070)

We can supply the screwdrivers above.

If you place order, please specify the Murata P/N.

2. Don't apply more than 9.8N (Ref.; 1kgf) of twist and stress after mounting onto PCB to prevent contact intermittence.

3. When adjusting with an adjustment tool, the applied force to the adjustment screw should not exceed 4.9N (Ref.; 500gf). If excessive force is applied, the trimmer potentiometer may not function due to damage.

4. When using a lock paint to fix slot position, please use adhesive resin without chlorine or sulfur (Three-bond "1401 series").

### Notice (Other)

1. Please make sure that your product has been evaluated and confirmed against your specifications when our product is mounted to your product.

2. Murata cannot guarantee trimmer potentiometer integrity when used under conditions other than those specified in this document.

# Trimmer Potentiometers



## SMD Sealed Type 4mm Size PVM4 Series

### ■ Features

1. Sealed construction protects the interior from dust and liquid, which achieves stable performance.
2. Available for flow and reflow soldering method while maintaining unique sealed construction.
3. Simple construction by 3-piece parts achieves high reliability.
4. Large diameter slot of rotor improves driver insertion.
5. Available for cleaning after soldering
6. High grade version is available (PVM4AxxxD01).
7. To be complied with RoHS directive by new Cd free cermet resistive material. Pb free terminals with Sn plating.

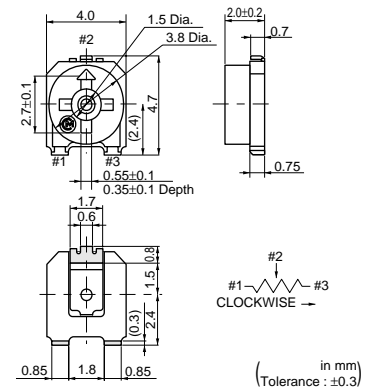

### ■ Applications

1. Security
2. OA, FA equipments
3. Measuring equipments
4. Professional cameras
5. Encoders
6. Sensors

5

Part Number	Power Rating	Soldering Method	Number of Turns (Effective Rotation Angle)	Total Resistance Value	TCR
PVM4A101C01	0.1W(70°C)	Flow/Reflow/Soldering Iron	1(240°±10°)	100ohm ±25%	±250ppm/°C
PVM4A201C01	0.1W(70°C)	Flow/Reflow/Soldering Iron	1(240°±10°)	200ohm ±25%	±250ppm/°C
PVM4A301C01	0.1W(70°C)	Flow/Reflow/Soldering Iron	1(240°±10°)	300ohm ±25%	±250ppm/°C
PVM4A501C01	0.1W(70°C)	Flow/Reflow/Soldering Iron	1(240°±10°)	500ohm ±25%	±250ppm/°C
PVM4A102C01	0.1W(70°C)	Flow/Reflow/Soldering Iron	1(240°±10°)	1k ohm ±25%	±250ppm/°C
PVM4A202C01	0.1W(70°C)	Flow/Reflow/Soldering Iron	1(240°±10°)	2k ohm ±25%	±250ppm/°C
PVM4A302C01	0.1W(70°C)	Flow/Reflow/Soldering Iron	1(240°±10°)	3k ohm ±25%	±250ppm/°C
PVM4A502C01	0.1W(70°C)	Flow/Reflow/Soldering Iron	1(240°±10°)	5k ohm ±25%	±250ppm/°C
PVM4A103C01	0.1W(70°C)	Flow/Reflow/Soldering Iron	1(240°±10°)	10k ohm ±25%	±250ppm/°C
PVM4A203C01	0.1W(70°C)	Flow/Reflow/Soldering Iron	1(240°±10°)	20k ohm ±25%	±250ppm/°C
PVM4A303C01	0.1W(70°C)	Flow/Reflow/Soldering Iron	1(240°±10°)	30k ohm ±25%	±250ppm/°C
PVM4A503C01	0.1W(70°C)	Flow/Reflow/Soldering Iron	1(240°±10°)	50k ohm ±25%	±250ppm/°C
PVM4A104C01	0.1W(70°C)	Flow/Reflow/Soldering Iron	1(240°±10°)	100k ohm ±25%	±250ppm/°C
PVM4A204C01	0.1W(70°C)	Flow/Reflow/Soldering Iron	1(240°±10°)	200k ohm ±25%	±250ppm/°C
PVM4A304C01	0.1W(70°C)	Flow/Reflow/Soldering Iron	1(240°±10°)	300k ohm ±25%	±250ppm/°C
PVM4A504C01	0.1W(70°C)	Flow/Reflow/Soldering Iron	1(240°±10°)	500k ohm ±25%	±250ppm/°C
PVM4A105C01	0.1W(70°C)	Flow/Reflow/Soldering Iron	1(240°±10°)	1M ohm ±25%	±250ppm/°C
PVM4A205C01	0.1W(70°C)	Flow/Reflow/Soldering Iron	1(240°±10°)	2M ohm ±25%	±250ppm/°C
PVM4A101D01	0.25W(70°C)	Flow/Reflow/Soldering Iron	1(240°±10°)	100ohm ±20%	±100ppm/°C
PVM4A201D01	0.25W(70°C)	Flow/Reflow/Soldering Iron	1(240°±10°)	200ohm ±20%	±100ppm/°C
PVM4A301D01	0.25W(70°C)	Flow/Reflow/Soldering Iron	1(240°±10°)	300ohm ±20%	±100ppm/°C
PVM4A501D01	0.25W(70°C)	Flow/Reflow/Soldering Iron	1(240°±10°)	500ohm ±20%	±100ppm/°C
PVM4A102D01	0.25W(70°C)	Flow/Reflow/Soldering Iron	1(240°±10°)	1k ohm ±20%	±200ppm/°C
PVM4A202D01	0.25W(70°C)	Flow/Reflow/Soldering Iron	1(240°±10°)	2k ohm ±20%	±200ppm/°C
PVM4A302D01	0.25W(70°C)	Flow/Reflow/Soldering Iron	1(240°±10°)	3k ohm ±20%	±200ppm/°C
PVM4A502D01	0.25W(70°C)	Flow/Reflow/Soldering Iron	1(240°±10°)	5k ohm ±20%	±200ppm/°C
PVM4A103D01	0.25W(70°C)	Flow/Reflow/Soldering Iron	1(240°±10°)	10k ohm ±20%	±150ppm/°C
PVM4A203D01	0.25W(70°C)	Flow/Reflow/Soldering Iron	1(240°±10°)	20k ohm ±20%	±150ppm/°C
PVM4A303D01	0.25W(70°C)	Flow/Reflow/Soldering Iron	1(240°±10°)	30k ohm ±20%	±150ppm/°C
PVM4A503D01	0.25W(70°C)	Flow/Reflow/Soldering Iron	1(240°±10°)	50k ohm ±20%	±150ppm/°C

Continued on the following page.

Continued from the preceding page.

Part Number	Power Rating	Soldering Method	Number of Turns (Effective Rotation Angle)	Total Resistance Value	TCR
PVM4A104D01	0.25W(70°C)	Flow/Reflow/Soldering Iron	1(240°±10°)	100k ohm ±20%	±150ppm/°C
PVM4A204D01	0.25W(70°C)	Flow/Reflow/Soldering Iron	1(240°±10°)	200k ohm ±20%	±150ppm/°C
PVM4A304D01	0.25W(70°C)	Flow/Reflow/Soldering Iron	1(240°±10°)	300k ohm ±20%	±150ppm/°C
PVM4A504D01	0.25W(70°C)	Flow/Reflow/Soldering Iron	1(240°±10°)	500k ohm ±20%	±150ppm/°C
PVM4A105D01	0.25W(70°C)	Flow/Reflow/Soldering Iron	1(240°±10°)	1M ohm ±20%	±150ppm/°C
PVM4A205D01	0.25W(70°C)	Flow/Reflow/Soldering Iron	1(240°±10°)	2M ohm ±20%	±150ppm/°C

The last three digits express the individual specification codes. C01 for standard type and D01 for high-liability type.

Part Number	Power Rating (W)	Soldering Method	Number of Turns (Effective Rotation Angle)	Total Resistance Value	TCR (ppm/°C)	Remarks	
PVM4A101A01	0.1(70°C)	Flow/Reflow/Soldering Iron	1(240°±10°)	100 ohm±25%	±250	Non Standard Product (Cd Free)	
PVM4A201A01	0.1(70°C)	Flow/Reflow/Soldering Iron	1(240°±10°)	200 ohm±25%	±250		
PVM4A301A01	0.1(70°C)	Flow/Reflow/Soldering Iron	1(240°±10°)	300 ohm±25%	±250		
PVM4A501A01	0.1(70°C)	Flow/Reflow/Soldering Iron	1(240°±10°)	500 ohm±25%	±250		
PVM4A102A01	0.1(70°C)	Flow/Reflow/Soldering Iron	1(240°±10°)	1k ohm±25%	±250		
PVM4A202A01	0.1(70°C)	Flow/Reflow/Soldering Iron	1(240°±10°)	2k ohm±25%	±250		
PVM4A302A01	0.1(70°C)	Flow/Reflow/Soldering Iron	1(240°±10°)	3k ohm±25%	±250		
PVM4A502A01	0.1(70°C)	Flow/Reflow/Soldering Iron	1(240°±10°)	5k ohm±25%	±250		
PVM4A103A01	0.1(70°C)	Flow/Reflow/Soldering Iron	1(240°±10°)	10k ohm±25%	±250		
PVM4A203A01	0.1(70°C)	Flow/Reflow/Soldering Iron	1(240°±10°)	20k ohm±25%	±250		
PVM4A303A01	0.1(70°C)	Flow/Reflow/Soldering Iron	1(240°±10°)	30k ohm±25%	±250	Non Standard Product (Cd included)	
PVM4A503A01	0.1(70°C)	Flow/Reflow/Soldering Iron	1(240°±10°)	50k ohm±25%	±250		
PVM4A104A01	0.1(70°C)	Flow/Reflow/Soldering Iron	1(240°±10°)	100k ohm±25%	±250		
PVM4A204A01	0.1(70°C)	Flow/Reflow/Soldering Iron	1(240°±10°)	200k ohm±25%	±250		
PVM4A304A01	0.1(70°C)	Flow/Reflow/Soldering Iron	1(240°±10°)	300k ohm±25%	±250		
PVM4A504A01	0.1(70°C)	Flow/Reflow/Soldering Iron	1(240°±10°)	500k ohm±25%	±250		
PVM4A105A01	0.1(70°C)	Flow/Reflow/Soldering Iron	1(240°±10°)	1M ohm±25%	±250		
PVM4A205A01	0.1(70°C)	Flow/Reflow/Soldering Iron	1(240°±10°)	2M ohm±25%	±250		
PVM4A101B01	0.25(70°C)	Flow/Reflow/Soldering Iron	1(240°±10°)	100 ohm±20%	±150		Non Standard Product (Cd Free)
PVM4A201B01	0.25(70°C)	Flow/Reflow/Soldering Iron	1(240°±10°)	200 ohm±20%	±100		
PVM4A301B01	0.25(70°C)	Flow/Reflow/Soldering Iron	1(240°±10°)	300 ohm±20%	±100		
PVM4A501B01	0.25(70°C)	Flow/Reflow/Soldering Iron	1(240°±10°)	500 ohm±20%	±100		
PVM4A102B01	0.25(70°C)	Flow/Reflow/Soldering Iron	1(240°±10°)	1k ohm±20%	±100		
PVM4A202B01	0.25(70°C)	Flow/Reflow/Soldering Iron	1(240°±10°)	2k ohm±20%	±100		
PVM4A302B01	0.25(70°C)	Flow/Reflow/Soldering Iron	1(240°±10°)	3k ohm±20%	±100		
PVM4A502B01	0.25(70°C)	Flow/Reflow/Soldering Iron	1(240°±10°)	5k ohm±20%	±100		
PVM4A103B01	0.25(70°C)	Flow/Reflow/Soldering Iron	1(240°±10°)	10k ohm±20%	±100		
PVM4A203B01	0.25(70°C)	Flow/Reflow/Soldering Iron	1(240°±10°)	20k ohm±20%	±100		
PVM4A303B01	0.25(70°C)	Flow/Reflow/Soldering Iron	1(240°±10°)	30k ohm±20%	±100	Non Standard Product (Cd included)	
PVM4A503B01	0.25(70°C)	Flow/Reflow/Soldering Iron	1(240°±10°)	50k ohm±20%	±100		
PVM4A104B01	0.25(70°C)	Flow/Reflow/Soldering Iron	1(240°±10°)	100k ohm±20%	±150		
PVM4A204B01	0.25(70°C)	Flow/Reflow/Soldering Iron	1(240°±10°)	200k ohm±20%	±150		
PVM4A304B01	0.25(70°C)	Flow/Reflow/Soldering Iron	1(240°±10°)	300k ohm±20%	±150		
PVM4A504B01	0.25(70°C)	Flow/Reflow/Soldering Iron	1(240°±10°)	500k ohm±20%	±150		
PVM4A105B01	0.25(70°C)	Flow/Reflow/Soldering Iron	1(240°±10°)	1M ohm±20%	±150		
PVM4A205B01	0.25(70°C)	Flow/Reflow/Soldering Iron	1(240°±10°)	2M ohm±20%	±150		

Continued on the following page. ↗

Continued from the preceding page.

■ Construction

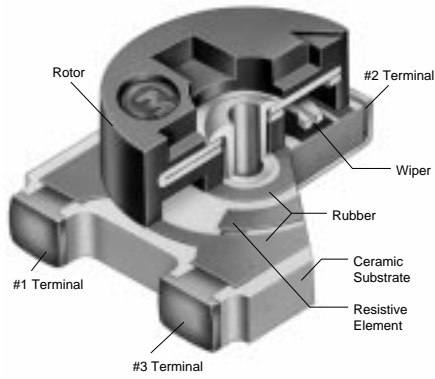

■ Standard Land Pattern

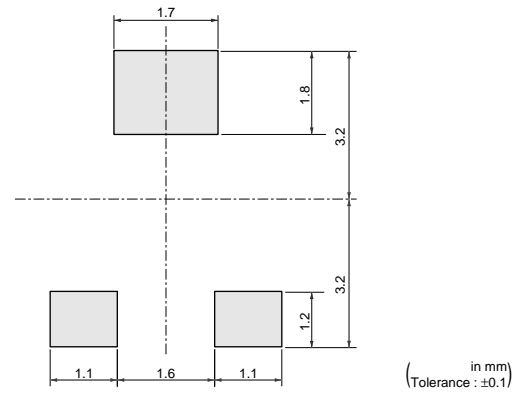

■ Characteristics

Item	PVM4A□□□C01	PVM4A□□□D01
Humidity Exposure	Res. Change : ±3%	Res. Change : ±2%
High Temperature Exposure	Res. Change : ±3%	Res. Change : ±2%
Humidity Load Life	Res. Change : ±3%	Res. Change : ±3%
Temperature Load Life	Res. Change : ±3%	Res. Change : ±3%
Temperature Cycle	Res. Change : ±3%	Res. Change : ±2%
Rotational Life	Res. Change : ±10% (20 cycles)	Res. Change : ±5% (100 cycles)

## PVM4 Series Notice

### ■ Notice (Operating and Storage Conditions)

1. Store in temperatures of -10 to +40 deg. C and relative humidity of 30-85%RH.
2. Do not store in or near corrosive gases.
3. Use within six months after delivery.
4. Open the package just before using.
5. Do not store under direct sunlight.
6. If you use the trimmer potentiometer in an environment other than listed below, please consult with a Murata factory representative prior to using.  
The trimmer potentiometer should not be used under

- the following environmental conditions:
- (1) Corrosive gaseous atmosphere  
(Ex. Chlorine gas, Hydrogen sulfide gas, Ammonia gas, Sulfuric acid gas, Nitric oxide gas, etc.)
  - (2) In liquid  
(Ex. Oil, Medical liquid, Organic solvent, etc.)
  - (3) Dusty / dirty atmosphere
  - (4) Direct sunlight
  - (5) Static voltage nor electric/magnetic fields
  - (6) Direct sea breeze
  - (7) Other variations of the above

### ■ Notice (Rating)

1. When using with partial load (rheostat), minimize the power depending on the resistance value.
2. The maximum input voltage to a trimmer potentiometer should not exceed  $(P.R)^{1/2}$  or the maximum operating voltage, whichever is smaller.
3. The maximum input current to a trimmer potentiometer should not exceed  $(P/R)^{1/2}$  or the allowable wiper current, whichever is smaller.

### ■ Notice (Soldering and Mounting)

1. Soldering
  - (1) Can be soldered by reflow soldering method, flow soldering method, and soldering iron. (In case of flow soldering, it is necessary to clean after soldering.)
  - (2) Use our standard land dimension. Excessive land area causes displacement due to the effect of the surface tension of the solder. Insufficient land area leads to insufficient soldering strength of the chip.
  - (3) Standard soldering condition
    - (a) Reflow and flow soldering :  
Refer to the standard temperature profile.
    - (b) Soldering iron:
      - >Temperature of tip 400 deg.C max.
      - >Soldering time 5 sec. max.
      - >Diameter 2mm dia. max.
      - >Wattage of iron 40W max.
- Before using other soldering conditions than those listed above, please consult with a Murata factory representative prior to using. If the soldering conditions are not suitable, e.g., excessive time and/or excessive temperature, the trimmer potentiometer may deviate from the specified characteristics.
- (4) Apply the appropriate amount of solder paste.  
The thickness of solder paste should be printed from 100 micro m to 150 micro m and the dimension of land pattern used should be Murata's standard land pattern at reflow soldering.

Insufficient amounts of solder can lead to insufficient soldering strength on PCB.  
Excessive amounts of solder may cause bridging between the terminals.

- (5) The soldering iron should not come in contact with the case of the trimmer potentiometer. If such contact does occur, the trimmer potentiometer may be damaged.
2. Mounting
  - (1) Do not apply excessive force (preferably 9.8N (Ref.; 1kgf) max.), when the trimmer potentiometer is mounted to the PCB.
  - (2) Do not warp and/or bend PC board to prevent trimmer potentiometer from breakage.
  - (3) In chip placers, the recommended size of the cylindrical pick-up nozzle should be outer dimension 4.0mm dia. and inner dimension 2.0mm dia.
3. Cleaning
  - (1) Isopropyl alcohol and Ethyl alcohol are available materials for cleaning.  
For other materials, please consult with a Murata factory representative prior to using.
  - (2) The following are the recommended cleaning conditions for the potentiometer. If this part is cleaned under any other conditions than these listed below, the sealing construction may be damaged.  
(Condition)  
Type1: Cold dipping/Max. 5 min.

Continued on the following page. 



## PVM4 Series Notice

Continued from the preceding page.

- Type2: Hot dipping/Max. 2 min.
- Type3: Ultra-sonic washing/Max. 1 min.  
(20W/litre or below)
- Type4: Hot dipping/Max. 1 min.+  
Ultra-sonic washing/Max.1 min.  
(20W/litre or below)
- Type5: Hot dipping/Max. 1 min.+  
Ultra-sonic washing/Max. 30 sec.+  
(20W/litre or below)/(Preferably max. 30 sec.)  
Vapor/Max.30 sec.

Due to ultra-sonic cleaning equipment's peculiar self-resonance point and that cleaning compatibility usually depends on the jig construction and/or the cleaning condition such as the depth of immersion, please check the cleaning equipment to determine the suitable conditions.

If the condition is not suitable, the trimmer potentiometer may deviate from specified characteristics.

### Flow Soldering Standard Profile

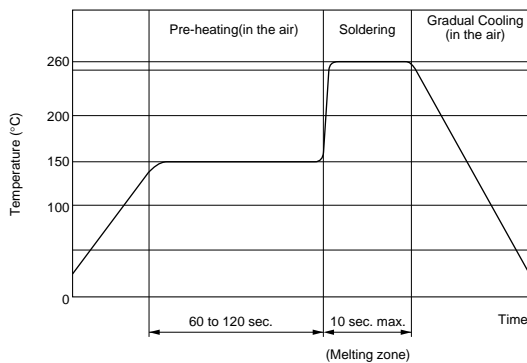

### Reflow Soldering Standard Profile

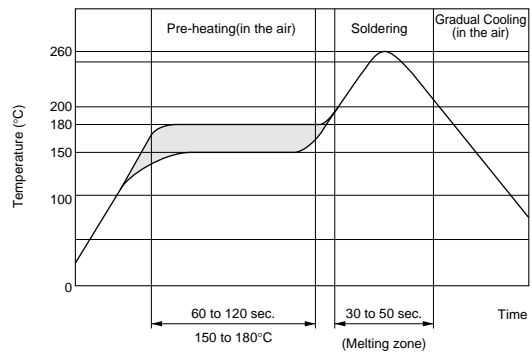

### Notice (Handling)

1. Use suitable screwdrivers that fit comfortably in driver slot. We recommend the screwdriver below.  
\* Recommended screwdriver for manual adjustment  
VESSEL MFG.: NO. 9000-2.6x30  
(Murata P/N : KMDR120)  
We can supply the screwdrivers above.  
If you place order, please specify the Murata P/N.
2. Don't apply more than 4.9N (Ref.; 500gf) of twist and stress after mounting onto PCB to prevent contact intermittence. If excessive force is

- applied, the trimmer potentiometer may not function.
3. Please use within the effective rotational angle.  
The potentiometer does not have a mechanical stop for over rotation. In cases out of effective rotational angle, the trimmer potentiometer may not function.
4. When using a lock paint to fix slot position, please use adhesive resin without chlorine or sulfur (Three-bond "1401 series").

### Notice (Other)

1. Please make sure that your product has been evaluated and confirmed against your specifications when our product is mounted to your product.
2. Murata cannot guarantee trimmer potentiometer integrity when used under conditions other than those specified in this document.

# Trimmer Potentiometers



## SMD Sealed Type Multi-turns PVG5/PV01 Series

### PVG5 Series

#### ■ Features

1. Sealed construction protects the interior from dust and liquid, which achieves stable performance.
2. Available with reflow soldering method
3. Available for ultrasonic cleaning after soldering
4. Clutch mechanism prevents excessive wiper rotation.
5. Both Top and side adjustment directions
6. Ultra smaller volume (1/5-1/2) than leaded multi-turn potentiometer.
7. To be complied with RoHS directive by new Cd free cermet resistive material. Pb free terminals with Sn plating.

#### ■ Applications

1. Measuring instruments
2. OA equipment
3. Medical equipment
4. Power supply
5. Sensors
6. Base station for cellular phone



PVG5A

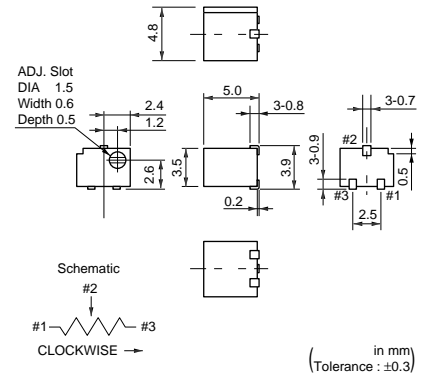

PVG5H

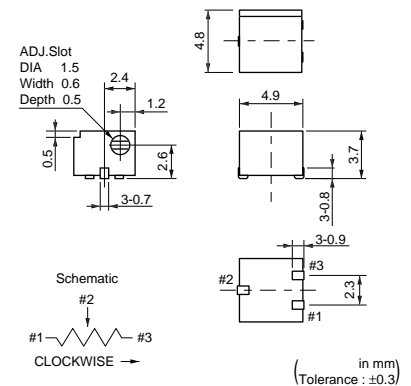

Part Number	Power Rating	Soldering Method	Number of Turns (Effective Rotation Angle)	Total Resistance Value	TCR
PVG5□100C01	0.25W(70°C)	Reflow/Soldering Iron	11	10ohm ±10%	±150ppm/°C
PVG5□200C01	0.25W(70°C)	Reflow/Soldering Iron	11	20ohm ±10%	±150ppm/°C
PVG5□500C01	0.25W(70°C)	Reflow/Soldering Iron	11	50ohm ±10%	±150ppm/°C
PVG5□101C01	0.25W(70°C)	Reflow/Soldering Iron	11	100ohm ±10%	±150ppm/°C
PVG5□201C01	0.25W(70°C)	Reflow/Soldering Iron	11	200ohm ±10%	±150ppm/°C
PVG5□501C01	0.25W(70°C)	Reflow/Soldering Iron	11	500ohm ±10%	±150ppm/°C
PVG5□102C01	0.25W(70°C)	Reflow/Soldering Iron	11	1k ohm ±10%	±150ppm/°C
PVG5□202C01	0.25W(70°C)	Reflow/Soldering Iron	11	2k ohm ±10%	±150ppm/°C
PVG5□502C01	0.25W(70°C)	Reflow/Soldering Iron	11	5k ohm ±10%	±150ppm/°C
PVG5□103C01	0.25W(70°C)	Reflow/Soldering Iron	11	10k ohm ±10%	±150ppm/°C
PVG5□203C01	0.25W(70°C)	Reflow/Soldering Iron	11	20k ohm ±10%	±150ppm/°C
PVG5□503C01	0.25W(70°C)	Reflow/Soldering Iron	11	50k ohm ±10%	±150ppm/°C
PVG5□104C01	0.25W(70°C)	Reflow/Soldering Iron	11	100k ohm ±10%	±150ppm/°C
PVG5□204C01	0.25W(70°C)	Reflow/Soldering Iron	11	200k ohm ±10%	±150ppm/°C
PVG5□504C01	0.25W(70°C)	Reflow/Soldering Iron	11	500k ohm ±10%	±150ppm/°C
PVG5□105C01	0.25W(70°C)	Reflow/Soldering Iron	11	1M ohm ±10%	±150ppm/°C
PVG5□205C01	0.25W(70°C)	Reflow/Soldering Iron	11	2M ohm ±10%	±150ppm/°C

The blank column is filled with the code of adjustment direction A (top) or H (side).

Part Number	Power Rating (W)	Soldering Method	Number of Turns (Effective Rotation Angle)	Total Resistance Value	TCR (ppm/°C)	Remarks
PVG5□100A01	0.25(70°C)	Reflow/Soldering Iron	11	10 ohm±10%	±200	Non Standard Product (Cd included)
PVG5□200A01	0.25(70°C)	Reflow/Soldering Iron	11	20 ohm±10%	±200	
PVG5□500A01	0.25(70°C)	Reflow/Soldering Iron	11	50 ohm±10%	±200	
PVG5□101A01	0.25(70°C)	Reflow/Soldering Iron	11	100 ohm±10%	±200	
PVG5□201A01	0.25(70°C)	Reflow/Soldering Iron	11	200 ohm±10%	±100	
PVG5□501A01	0.25(70°C)	Reflow/Soldering Iron	11	500 ohm±10%	±100	
PVG5□102A01	0.25(70°C)	Reflow/Soldering Iron	11	1k ohm±10%	±100	
PVG5□202A01	0.25(70°C)	Reflow/Soldering Iron	11	2k ohm±10%	±100	
PVG5□502A01	0.25(70°C)	Reflow/Soldering Iron	11	5k ohm±10%	±100	
PVG5□103A01	0.25(70°C)	Reflow/Soldering Iron	11	10k ohm±10%	±100	
PVG5□203A01	0.25(70°C)	Reflow/Soldering Iron	11	20k ohm±10%	±100	
PVG5□503A01	0.25(70°C)	Reflow/Soldering Iron	11	50k ohm±10%	±100	
PVG5□104A01	0.25(70°C)	Reflow/Soldering Iron	11	100k ohm±10%	±100	
PVG5□204A01	0.25(70°C)	Reflow/Soldering Iron	11	200k ohm±10%	±100	
PVG5□504A01	0.25(70°C)	Reflow/Soldering Iron	11	500k ohm±10%	±100	
PVG5□105A01	0.25(70°C)	Reflow/Soldering Iron	11	1M ohm±10%	±100	
PVG5□205A01	0.25(70°C)	Reflow/Soldering Iron	11	2M ohm±10%	±100	

■ Construction

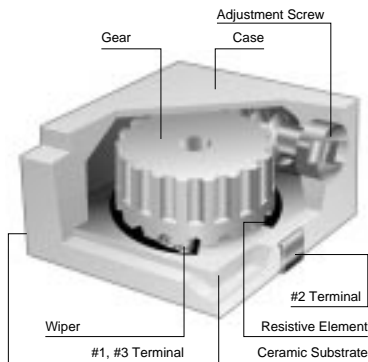

6

■ Standard Land Pattern

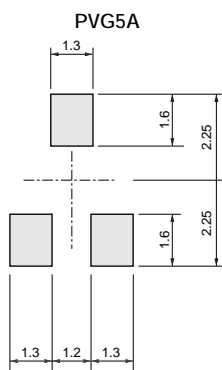

(in mm)  
(Tolerance : ±0.1)

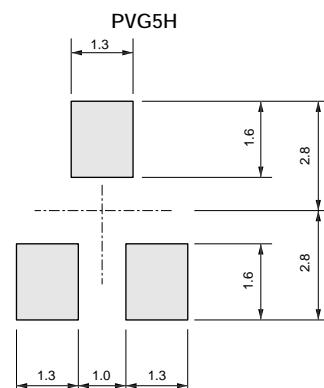

(in mm)  
(Tolerance : ±0.1)

Continued on the following page.

☐ Continued from the preceding page.

## ■ Characteristics

Temperature Cycle	$\Delta$ TR	$\pm 2\%$
	$\Delta$ V.S.S.	$\pm 1\%$
Humidity	$\Delta$ TR	$\pm 2\%$
	IR	10Mohm min.
Vibration	$\Delta$ TR	$\pm 1\%$
	$\Delta$ V.S.S.	$\pm 1\%$
Shock	$\Delta$ TR	$\pm 1\%$
	$\Delta$ V.S.S.	$\pm 1\%$
Temperature Load Life	$\Delta$ TR	$\pm 3\%$ or 3ohm max., whichever is greater
	$\Delta$ V.S.S.	$\pm 1\%$
Low Temperature Exposure	$\Delta$ TR	$\pm 1\%$
	$\Delta$ V.S.S.	$\pm 1\%$
High Temperature Exposure	$\Delta$ TR	$\pm 2\%$
	$\Delta$ V.S.S.	$\pm 1\%$
Rotational Life (100 cycles)	$\Delta$ TR	$\pm 3\%$ or 3ohm max., whichever is greater

$\Delta$ TR : Total Resistance Change

$\Delta$ V.S.S. : Voltage Setting Stability

IR : Insulation Resistance

## PV01 Series

### ■ Features

1. Small size (6.35x6.35x4.3mm)
2. Sealed construction protects the interior from dust and liquid, which achieves stable performance.
3. Available with reflow soldering method
4. Available for ultrasonic cleaning after soldering
5. Clutch mechanism prevents excessive wiper rotation.
6. To be complied with RoHS directive by new Cd free cermet resistive material. Pb free terminals with Sn plating.

### ■ Applications

1. Measuring instruments
2. FAX
3. PPCs
4. Printers
5. Sensors



PV01P

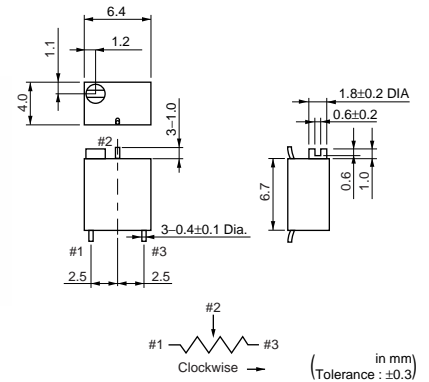

PV01W

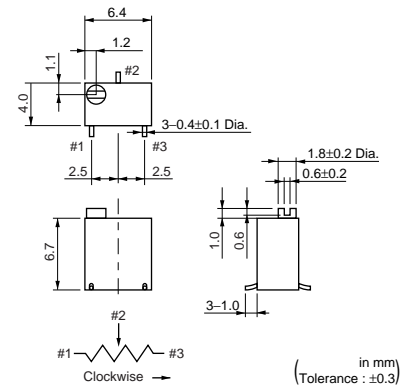

PV01X

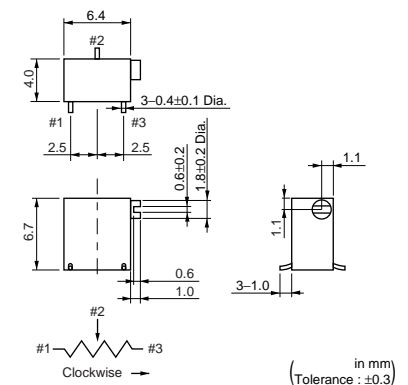

Part Number	Power Rating	Soldering Method	Number of Turns (Effective Rotation Angle)	Total Resistance Value	TCR
PV01□100C01	0.25W(85°C)	Reflow/Soldering Iron	12	10ohm ±10%	±150ppm/°C
PV01□200C01	0.25W(85°C)	Reflow/Soldering Iron	12	20ohm ±10%	±150ppm/°C
PV01□500C01	0.25W(85°C)	Reflow/Soldering Iron	12	50ohm ±10%	±150ppm/°C
PV01□101C01	0.25W(85°C)	Reflow/Soldering Iron	12	100ohm ±10%	±150ppm/°C
PV01□201C01	0.25W(85°C)	Reflow/Soldering Iron	12	200ohm ±10%	±150ppm/°C
PV01□501C01	0.25W(85°C)	Reflow/Soldering Iron	12	500ohm ±10%	±150ppm/°C
PV01□102C01	0.25W(85°C)	Reflow/Soldering Iron	12	1k ohm ±10%	±150ppm/°C
PV01□202C01	0.25W(85°C)	Reflow/Soldering Iron	12	2k ohm ±10%	±150ppm/°C
PV01□502C01	0.25W(85°C)	Reflow/Soldering Iron	12	5k ohm ±10%	±150ppm/°C
PV01□103C01	0.25W(85°C)	Reflow/Soldering Iron	12	10k ohm ±10%	±150ppm/°C
PV01□203C01	0.25W(85°C)	Reflow/Soldering Iron	12	20k ohm ±10%	±150ppm/°C
PV01□253C01	0.25W(85°C)	Reflow/Soldering Iron	12	25k ohm ±10%	±150ppm/°C
PV01□503C01	0.25W(85°C)	Reflow/Soldering Iron	12	50k ohm ±10%	±150ppm/°C
PV01□104C01	0.25W(85°C)	Reflow/Soldering Iron	12	100k ohm ±10%	±150ppm/°C
PV01□204C01	0.25W(85°C)	Reflow/Soldering Iron	12	200k ohm ±10%	±150ppm/°C
PV01□254C01	0.25W(85°C)	Reflow/Soldering Iron	12	250k ohm ±10%	±150ppm/°C

Continued on the following page. ↗

Continued from the preceding page.

Part Number	Power Rating	Soldering Method	Number of Turns (Effective Rotation Angle)	Total Resistance Value	TCR
PV01□504C01	0.25W(85°C)	Reflow/Soldering Iron	12	500k ohm ±10%	±150ppm/°C
PV01□105C01	0.25W(85°C)	Reflow/Soldering Iron	12	1M ohm ±10%	±150ppm/°C

The blank column is filled with the code of adjustment direction P (side), W (top) or X (side).  
Magazine packaging is standard for PV01 series.

Part Number	Power Rating (W)	Soldering Method	Number of Turns (Effective Rotation Angle)	Total Resistance Value	TCR (ppm/°C)	Remarks
PV01□100A01	0.25(85°C)	Reflow/Soldering Iron	12	10 ohm±10%	±100	Non Standard Product (Cd included)
PV01□200A01	0.25(85°C)	Reflow/Soldering Iron	12	20 ohm±10%	±100	
PV01□500A01	0.25(85°C)	Reflow/Soldering Iron	12	50 ohm±10%	±100	
PV01□101A01	0.25(85°C)	Reflow/Soldering Iron	12	100 ohm±10%	±100	
PV01□201A01	0.25(85°C)	Reflow/Soldering Iron	12	200 ohm±10%	±100	
PV01□501A01	0.25(85°C)	Reflow/Soldering Iron	12	500 ohm±10%	±100	
PV01□102A01	0.25(85°C)	Reflow/Soldering Iron	12	1k ohm±10%	±100	
PV01□202A01	0.25(85°C)	Reflow/Soldering Iron	12	2k ohm±10%	±100	
PV01□502A01	0.25(85°C)	Reflow/Soldering Iron	12	5k ohm±10%	±100	
PV01□103A01	0.25(85°C)	Reflow/Soldering Iron	12	10k ohm±10%	±100	
PV01□203A01	0.25(85°C)	Reflow/Soldering Iron	12	20k ohm±10%	±100	
PV01□253A01	0.25(85°C)	Reflow/Soldering Iron	12	25k ohm±10%	±100	
PV01□503A01	0.25(85°C)	Reflow/Soldering Iron	12	50k ohm±10%	±100	
PV01□104A01	0.25(85°C)	Reflow/Soldering Iron	12	100k ohm±10%	±100	
PV01□204A01	0.25(85°C)	Reflow/Soldering Iron	12	200k ohm±10%	±100	
PV01□254A01	0.25(85°C)	Reflow/Soldering Iron	12	250k ohm±10%	±100	
PV01□504A01	0.25(85°C)	Reflow/Soldering Iron	12	500k ohm±10%	±100	
PV01□105A01	0.25(85°C)	Reflow/Soldering Iron	12	1M ohm±10%	±100	

■ Construction

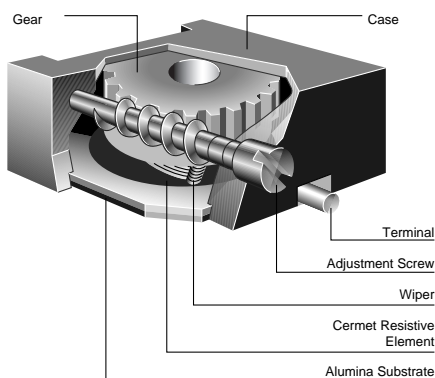

6

■ Standard Land Pattern

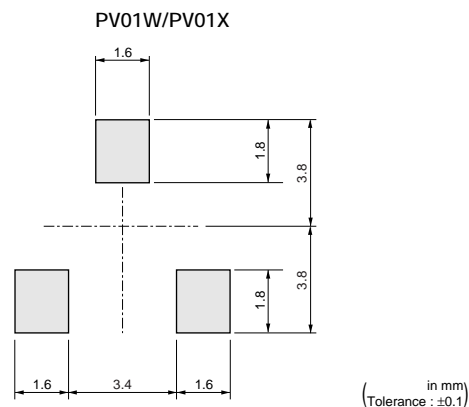
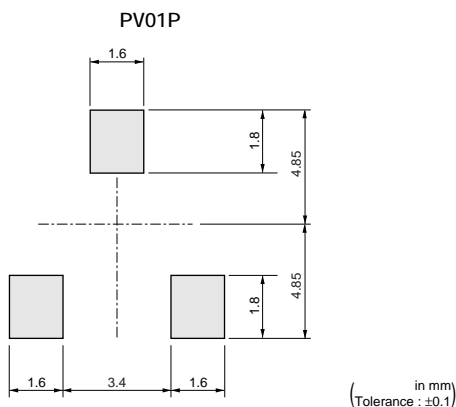

Continued on the following page. ↗

↳ Continued from the preceding page.

## ■ Characteristics

Temperature Cycle	$\Delta TR$	$\pm 1\%$
	$\Delta V.S.S.$	$\pm 1\%$
Humidity	$\Delta TR$	$\pm 2\%$
	IR	100Mohm min.
Vibration (20G)	$\Delta TR$	$\pm 1\%$
	$\Delta V.S.S.$	$\pm 1\%$
Shock (100G)	$\Delta TR$	$\pm 1\%$
	$\Delta V.S.S.$	$\pm 1\%$
Temperature Load Life	$\Delta TR$	$\pm 2\%$
	$\Delta V.S.S.$	$\pm 1\%$
Low Temperature Exposure	$\Delta TR$	$\pm 1\%$
	$\Delta V.S.S.$	$\pm 1\%$
High Temperature Exposure	$\Delta TR$	$\pm 2\%$
	$\Delta V.S.S.$	$\pm 1\%$
Rotational Life (200 cycles)	$\Delta TR$	R $\leq$ 100ohm ... $\pm 3\%$
		R $>$ 100ohm ... $\pm 2\%$

$\Delta TR$  : Total Resistance Change  
 $\Delta V.S.S.$  : Voltage Setting Stability  
 IR : Insulation Resistance  
 R : Standard Total Resistance

## PVG5/PV01 Series Notice

### ■ Notice (Operating and Storage Conditions)

1. Store in temperatures of -10 to +40 deg. C and relative humidity of 30-85%RH.
2. Do not store in or near corrosive gases.
3. Use within six months after delivery.
4. Open the package just before using.
5. Do not store under direct sunlight.
6. If you use the trimmer potentiometer in an environment other than listed below, please consult with a Murata factory representative prior to using.  
The trimmer potentiometer should not be used under

- the following environmental conditions:
- (1) Corrosive gaseous atmosphere  
(Ex. Chlorine gas, Hydrogen sulfide gas, Ammonia gas, Sulfuric acid gas, Nitric oxide gas, etc.)
  - (2) In liquid  
(Ex. Oil, Medical liquid, Organic solvent, etc.)
  - (3) Dusty / dirty atmosphere
  - (4) Direct sunlight
  - (5) Static voltage nor electric/magnetic fields
  - (6) Direct sea breeze
  - (7) Other variations of the above

### ■ Notice (Rating)

1. When using with partial load (rheostat), minimize the power depending on the resistance value.
2. The maximum input voltage to a trimmer potentiometer should not exceed  $(P.R)^{1/2}$  or the maximum operating voltage, whichever is smaller.
3. The maximum input current to a trimmer potentiometer should not exceed  $(P/R)^{1/2}$  or the allowable wiper current, whichever is smaller.

### ■ Notice (Soldering and Mounting)

1. Soldering
  - (1) Standard soldering condition
    - (a) Reflow and flow soldering:  
Refer to the standard temperature profile.
    - (b) Soldering iron:
      - >Temperature of tip 260 deg.C max.
      - >Soldering time 3 sec. max.
      - >Diameter 2mm dia. max.
      - >Wattage of iron 30W max.

Before using other soldering conditions than those listed above, please consult with a Murata factory representative prior to using. If the soldering conditions are not suitable, e.g., excessive time and/or excessive temperature, the trimmer capacitor may deviate from the specified characteristics.

  - (2) Cannot be soldered using the flow soldering method. If you use the flow soldering method, the trimmer potentiometer may not function.
  - (3) The soldering iron should not come in contact with the case of the trimmer potentiometer. If such contact does occur, the trimmer potentiometer may be damaged.
  - (4) Insufficient amounts of solder can lead to insufficient soldering strength on PCB.  
Excessive amounts of solder may cause bridging between the terminals.
2. Mounting
  - (1) Use our standard land dimension. Excessive land area causes displacement due to the effect of the

- surface tension of the solder. Insufficient land area leads to insufficient soldering strength of the chip.
- (2) Do not apply excessive force (preferably 9.8N (Ref.; 1kgf) max.), when the trimmer potentiometer is mounted to the PCB.
  - (3) Do not warp and/or bend PC board to prevent trimmer potentiometer from breakage.
  - (4) In chip placers, the recommended size of the cylindrical pick-up nozzle should be outer dimension 4.0mm dia. and inner dimension 2.0mm dia.
3. Cleaning
    - (1) Isopropyl-alcohol and Ethyl-alcohol are applicable solvents for cleaning. If you use any other types of solvents, please consult with a Murata factory representative prior to using.
    - (2) The total cleaning time by cold dipping, vapor and ultrasonic washing (conditions as below) method should be less than 3 minutes.
    - (3) For ultra-sonic cleaning, the available condition is as follows.
      - >Power: 600W (67 liter) max.
      - >Frequency: 28kHz
      - >Temperature: Ambient temperatureDue to the ultra-sonic cleaning equipment's peculiar self-resonance point and that the cleaning compatibility usually depends on the jig construction and/or the cleaning condition such as the depth of immersion, please check the



## PVG5/PV01 Series Notice

Continued from the preceding page.

cleaning equipment to determine the suitable conditions.

If the trimmer potentiometer is cleaned by other

conditions, the trimmer potentiometer may be damaged.

### Reflow Soldering Standard Profile

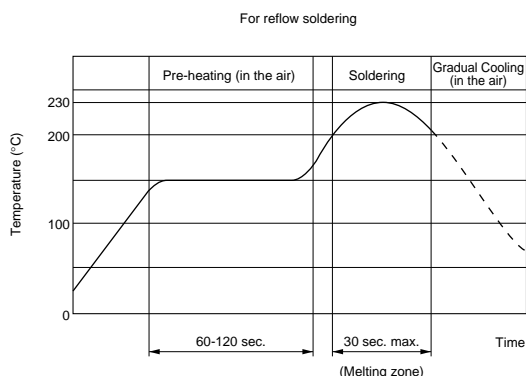

### Notice (Handling)

1. Use suitable screwdrivers that fit comfortably in driver slot. We recommend the screwdrivers below.  
\* Recommended screwdrivers for manual adjustment

<PVG5 series>

VESSEL MFG. : NO.9000-1.3x30

(Murata P/N : KMDR130)

<PV01 series>

ENGINEER INC. : DA-40

(Murata P/N : KMDR180)

We can supply the screwdrivers above.

If you place order, please specify Murata P/N.

2. Don't apply more than 9.8N (Ref.; 1kgf) of twist and stress after mounting onto PCB to prevent contact intermittence. If excessive force is applied, the trimmer potentiometer may not function.
3. When adjusting with a screwdriver, do not apply excessive force (preferable 4.9N (Ref; 500gf) max.)
4. When using a lock paint to fix slot position, please use adhesive resin without chlorine or sulfur (Three-bond "1401 series").

### Notice (Other)

1. Please make sure that your product has been evaluated and confirmed against your specifications when our product is mounted to your product.
2. Murata cannot guarantee trimmer potentiometer integrity when used under conditions other than those specified in this document.

# Trimmer Potentiometers



## Lead Sealed Type Single-turn PVC6/PV32/PV34 Series

### PVC6 Series

#### ■ Features

1. Enlarged and colored rotor provides superior adjustability.
2. Cone-shaped rotor improves driver insertion during automatic adjustment.
3. Available for "Zero" plus adjustment tool (taper head) use
4. Easy to see 11-scales adjustment positions.
5. Sealed construction protects the interior from dust and liquid, which achieves stable performance.
6. Available for ultrasonic cleaning after soldering
7. During cutting process by the inserter machine, the round shaped lead wire prevents clinch problems and realizes longer life of cutter than flat shaped lead wire.
8. Flammability: UL94V-0
9. To be complied with RoHS directive by new Cd free cermet resistive material. Pb free terminals with Sn plating.

#### ■ Applications

- |                 |                         |
|-----------------|-------------------------|
| 1. DY           | 2. CRT display          |
| 3. Power supply | 4. Professional cameras |
| 5. CATV         | 6. FAX                  |
| 7. Printers     | 8. OA Equipment         |
| 9. Sensors      |                         |

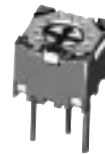

PVC6A

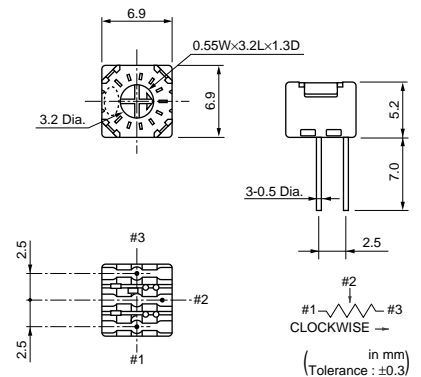

PVC6D

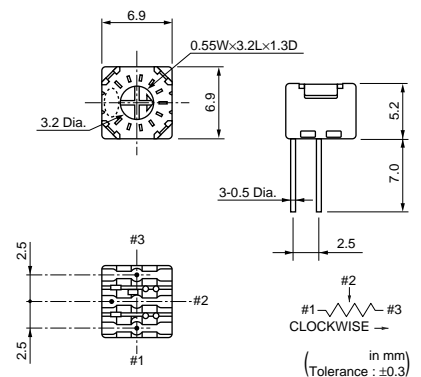

PVC6E

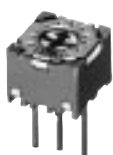
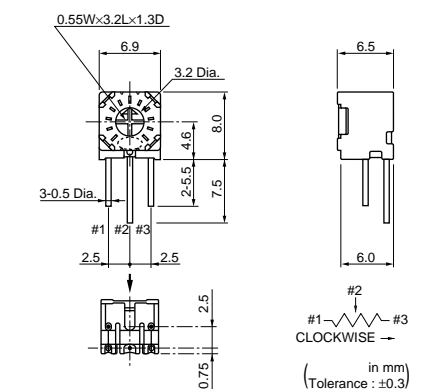

PVC6M

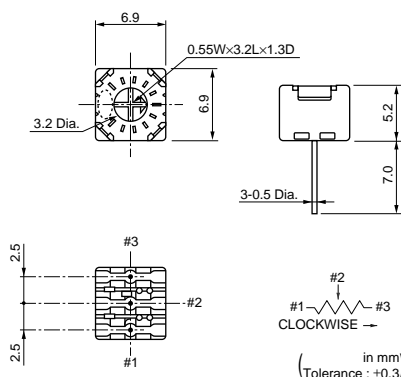

PVC6H

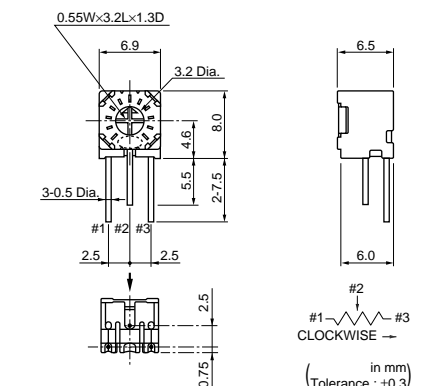

Continued on the following page.

Continued from the preceding page.

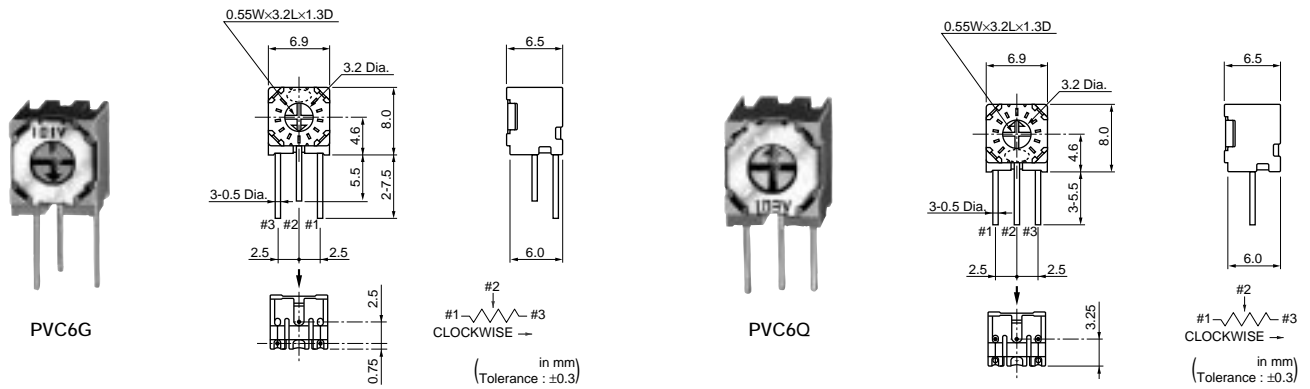

Part Number	Power Rating	Soldering Method	Number of Turns (Effective Rotation Angle)	Total Resistance Value	TCR
PVC6□100C01	0.5W(70°C)	Flow/Soldering Iron	1(240°±5°)	10ohm ±10%	±100ppm/°C
PVC6□200C01	0.5W(70°C)	Flow/Soldering Iron	1(240°±5°)	20ohm ±10%	±100ppm/°C
PVC6□250C01	0.5W(70°C)	Flow/Soldering Iron	1(240°±5°)	25ohm ±10%	±100ppm/°C
PVC6□500C01	0.5W(70°C)	Flow/Soldering Iron	1(240°±5°)	50ohm ±10%	±100ppm/°C
PVC6□101C01	0.5W(70°C)	Flow/Soldering Iron	1(240°±5°)	100ohm ±10%	±100ppm/°C
PVC6□201C01	0.5W(70°C)	Flow/Soldering Iron	1(240°±5°)	200ohm ±10%	±100ppm/°C
PVC6□251C01	0.5W(70°C)	Flow/Soldering Iron	1(240°±5°)	250ohm ±10%	±100ppm/°C
PVC6□501C01	0.5W(70°C)	Flow/Soldering Iron	1(240°±5°)	500ohm ±10%	±100ppm/°C
PVC6□102C01	0.5W(70°C)	Flow/Soldering Iron	1(240°±5°)	1k ohm ±10%	±100ppm/°C
PVC6□202C01	0.5W(70°C)	Flow/Soldering Iron	1(240°±5°)	2k ohm ±10%	±100ppm/°C
PVC6□252C01	0.5W(70°C)	Flow/Soldering Iron	1(240°±5°)	2.5k ohm ±10%	±100ppm/°C
PVC6□502C01	0.5W(70°C)	Flow/Soldering Iron	1(240°±5°)	5k ohm ±10%	±100ppm/°C
PVC6□103C01	0.5W(70°C)	Flow/Soldering Iron	1(240°±5°)	10k ohm ±10%	±100ppm/°C
PVC6□203C01	0.5W(70°C)	Flow/Soldering Iron	1(240°±5°)	20k ohm ±10%	±100ppm/°C
PVC6□253C01	0.5W(70°C)	Flow/Soldering Iron	1(240°±5°)	25k ohm ±10%	±100ppm/°C
PVC6□503C01	0.5W(70°C)	Flow/Soldering Iron	1(240°±5°)	50k ohm ±10%	±100ppm/°C
PVC6□104C01	0.5W(70°C)	Flow/Soldering Iron	1(240°±5°)	100k ohm ±10%	±100ppm/°C
PVC6□204C01	0.5W(70°C)	Flow/Soldering Iron	1(240°±5°)	200k ohm ±10%	±100ppm/°C
PVC6□254C01	0.5W(70°C)	Flow/Soldering Iron	1(240°±5°)	250k ohm ±10%	±100ppm/°C
PVC6□504C01	0.5W(70°C)	Flow/Soldering Iron	1(240°±5°)	500k ohm ±10%	±100ppm/°C
PVC6□105C01	0.5W(70°C)	Flow/Soldering Iron	1(240°±5°)	1M ohm ±10%	±100ppm/°C
PVC6□205C01	0.5W(70°C)	Flow/Soldering Iron	1(240°±5°)	2M ohm ±10%	±100ppm/°C
PVC6□505C01	0.5W(70°C)	Flow/Soldering Iron	1(240°±5°)	5M ohm ±10%	±100ppm/°C
PVC6□100C04	0.5W(70°C)	Flow/Soldering Iron	1(240°±5°)	10ohm ±10%	±100ppm/°C
PVC6□200C04	0.5W(70°C)	Flow/Soldering Iron	1(240°±5°)	20ohm ±10%	±100ppm/°C
PVC6□250C04	0.5W(70°C)	Flow/Soldering Iron	1(240°±5°)	25ohm ±10%	±100ppm/°C
PVC6□500C04	0.5W(70°C)	Flow/Soldering Iron	1(240°±5°)	50ohm ±10%	±100ppm/°C
PVC6□101C04	0.5W(70°C)	Flow/Soldering Iron	1(240°±5°)	100ohm ±10%	±100ppm/°C
PVC6□201C04	0.5W(70°C)	Flow/Soldering Iron	1(240°±5°)	200ohm ±10%	±100ppm/°C
PVC6□251C04	0.5W(70°C)	Flow/Soldering Iron	1(240°±5°)	250ohm ±10%	±100ppm/°C
PVC6□501C04	0.5W(70°C)	Flow/Soldering Iron	1(240°±5°)	500ohm ±10%	±100ppm/°C
PVC6□102C04	0.5W(70°C)	Flow/Soldering Iron	1(240°±5°)	1k ohm ±10%	±100ppm/°C
PVC6□202C04	0.5W(70°C)	Flow/Soldering Iron	1(240°±5°)	2k ohm ±10%	±100ppm/°C
PVC6□252C04	0.5W(70°C)	Flow/Soldering Iron	1(240°±5°)	2.5k ohm ±10%	±100ppm/°C
PVC6□502C04	0.5W(70°C)	Flow/Soldering Iron	1(240°±5°)	5k ohm ±10%	±100ppm/°C
PVC6□103C04	0.5W(70°C)	Flow/Soldering Iron	1(240°±5°)	10k ohm ±10%	±100ppm/°C
PVC6□203C04	0.5W(70°C)	Flow/Soldering Iron	1(240°±5°)	20k ohm ±10%	±100ppm/°C
PVC6□253C04	0.5W(70°C)	Flow/Soldering Iron	1(240°±5°)	25k ohm ±10%	±100ppm/°C
PVC6□503C04	0.5W(70°C)	Flow/Soldering Iron	1(240°±5°)	50k ohm ±10%	±100ppm/°C
PVC6□104C04	0.5W(70°C)	Flow/Soldering Iron	1(240°±5°)	100k ohm ±10%	±100ppm/°C
PVC6□204C04	0.5W(70°C)	Flow/Soldering Iron	1(240°±5°)	200k ohm ±10%	±100ppm/°C
PVC6□254C04	0.5W(70°C)	Flow/Soldering Iron	1(240°±5°)	250k ohm ±10%	±100ppm/°C
PVC6□504C04	0.5W(70°C)	Flow/Soldering Iron	1(240°±5°)	500k ohm ±10%	±100ppm/°C
PVC6□105C04	0.5W(70°C)	Flow/Soldering Iron	1(240°±5°)	1M ohm ±10%	±100ppm/°C

Continued on the following page. ↗

Continued from the preceding page.

Part Number	Power Rating	Soldering Method	Number of Turns (Effective Rotation Angle)	Total Resistance Value	TCR
PVC6□205C04	0.5W(70°C)	Flow/Soldering Iron	1(240°±5°)	2M ohm ±10%	±100ppm/°C
PVC6□505C04	0.5W(70°C)	Flow/Soldering Iron	1(240°±5°)	5M ohm ±10%	±100ppm/°C

Operating Temperature Range: -55 to 125 °C

The blank column is filled with the code of adjustment direction and lead type (A, D, E, G, H, M and Q).

The order quantity should be an integral multiple of the "Minimum Quantity" .

The last three digits express the individual specification codes. C01 for standard type and C04 for radial taping type (PVC6M/PVC6Q series only).

Part Number	Power Rating (W)	Soldering Method	Number of Turns (Effective Rotation Angle)	Total Resistance Value	TCR (ppm/°C)	Remarks
PVC6□100A01	0.5(70°C)	Flow/Soldering Iron	1(240°±5°)	10 ohm±10%	±100	Non Standard Product (Cd Free)
PVC6□200A01	0.5(70°C)	Flow/Soldering Iron	1(240°±5°)	20 ohm±10%	±100	
PVC6□250A01	0.5(70°C)	Flow/Soldering Iron	1(240°±5°)	25 ohm±10%	±100	
PVC6□500A01	0.5(70°C)	Flow/Soldering Iron	1(240°±5°)	50 ohm±10%	±100	
PVC6□101A01	0.5(70°C)	Flow/Soldering Iron	1(240°±5°)	100 ohm±10%	±100	
PVC6□201A01	0.5(70°C)	Flow/Soldering Iron	1(240°±5°)	200 ohm±10%	±100	
PVC6□251A01	0.5(70°C)	Flow/Soldering Iron	1(240°±5°)	250 ohm±10%	±100	
PVC6□501A01	0.5(70°C)	Flow/Soldering Iron	1(240°±5°)	500 ohm±10%	±100	
PVC6□102A01	0.5(70°C)	Flow/Soldering Iron	1(240°±5°)	1k ohm±10%	±100	Non Standard Product (Cd included)
PVC6□202A01	0.5(70°C)	Flow/Soldering Iron	1(240°±5°)	2k ohm±10%	±100	
PVC6□252A01	0.5(70°C)	Flow/Soldering Iron	1(240°±5°)	2.5k ohm±10%	±100	
PVC6□502A01	0.5(70°C)	Flow/Soldering Iron	1(240°±5°)	5k ohm±10%	±100	
PVC6□103A01	0.5(70°C)	Flow/Soldering Iron	1(240°±5°)	10k ohm±10%	±100	
PVC6□203A01	0.5(70°C)	Flow/Soldering Iron	1(240°±5°)	20k ohm±10%	±100	
PVC6□253A01	0.5(70°C)	Flow/Soldering Iron	1(240°±5°)	25k ohm±10%	±100	
PVC6□503A01	0.5(70°C)	Flow/Soldering Iron	1(240°±5°)	50k ohm±10%	±100	
PVC6□104A01	0.5(70°C)	Flow/Soldering Iron	1(240°±5°)	100k ohm±10%	±100	
PVC6□204A01	0.5(70°C)	Flow/Soldering Iron	1(240°±5°)	200k ohm±10%	±100	
PVC6□254A01	0.5(70°C)	Flow/Soldering Iron	1(240°±5°)	250k ohm±10%	±100	
PVC6□504A01	0.5(70°C)	Flow/Soldering Iron	1(240°±5°)	500k ohm±10%	±100	
PVC6□105A01	0.5(70°C)	Flow/Soldering Iron	1(240°±5°)	1M ohm±10%	±100	
PVC6□205A01	0.5(70°C)	Flow/Soldering Iron	1(240°±5°)	2M ohm±10%	±100	
PVC6□505A01	0.5(70°C)	Flow/Soldering Iron	1(240°±5°)	5M ohm±10%	±100	
PVC6□100A04	0.5(70°C)	Flow/Soldering Iron	1(240°±5°)	10 ohm±10%	±100	
PVC6□200A04	0.5(70°C)	Flow/Soldering Iron	1(240°±5°)	20 ohm±10%	±100	
PVC6□250A04	0.5(70°C)	Flow/Soldering Iron	1(240°±5°)	25 ohm±10%	±100	
PVC6□500A04	0.5(70°C)	Flow/Soldering Iron	1(240°±5°)	50 ohm±10%	±100	
PVC6□101A04	0.5(70°C)	Flow/Soldering Iron	1(240°±5°)	100 ohm±10%	±100	
PVC6□201A04	0.5(70°C)	Flow/Soldering Iron	1(240°±5°)	200 ohm±10%	±100	
PVC6□251A04	0.5(70°C)	Flow/Soldering Iron	1(240°±5°)	250 ohm±10%	±100	
PVC6□501A04	0.5(70°C)	Flow/Soldering Iron	1(240°±5°)	500 ohm±10%	±100	
PVC6□102A04	0.5(70°C)	Flow/Soldering Iron	1(240°±5°)	1k ohm±10%	±100	Non Standard Product (Cd included)
PVC6□202A04	0.5(70°C)	Flow/Soldering Iron	1(240°±5°)	2k ohm±10%	±100	
PVC6□252A04	0.5(70°C)	Flow/Soldering Iron	1(240°±5°)	2.5k ohm±10%	±100	
PVC6□502A04	0.5(70°C)	Flow/Soldering Iron	1(240°±5°)	5k ohm±10%	±100	
PVC6□103A04	0.5(70°C)	Flow/Soldering Iron	1(240°±5°)	10k ohm±10%	±100	
PVC6□203A04	0.5(70°C)	Flow/Soldering Iron	1(240°±5°)	20k ohm±10%	±100	
PVC6□253A04	0.5(70°C)	Flow/Soldering Iron	1(240°±5°)	25k ohm±10%	±100	
PVC6□503A04	0.5(70°C)	Flow/Soldering Iron	1(240°±5°)	50k ohm±10%	±100	
PVC6□104A04	0.5(70°C)	Flow/Soldering Iron	1(240°±5°)	100k ohm±10%	±100	
PVC6□204A04	0.5(70°C)	Flow/Soldering Iron	1(240°±5°)	200k ohm±10%	±100	
PVC6□254A04	0.5(70°C)	Flow/Soldering Iron	1(240°±5°)	250k ohm±10%	±100	
PVC6□504A04	0.5(70°C)	Flow/Soldering Iron	1(240°±5°)	500k ohm±10%	±100	
PVC6□105A04	0.5(70°C)	Flow/Soldering Iron	1(240°±5°)	1M ohm±10%	±100	
PVC6□205A04	0.5(70°C)	Flow/Soldering Iron	1(240°±5°)	2M ohm±10%	±100	
PVC6□505A04	0.5(70°C)	Flow/Soldering Iron	1(240°±5°)	5M ohm±10%	±100	

Continued on the following page.

Continued from the preceding page.

■ Construction

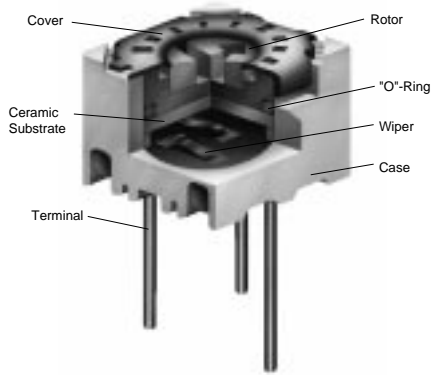

■ Mounting Holes

PVC6A/PVC6E

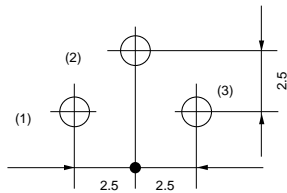

(Tolerance:±0.1 in mm)

PVC6D/PVC6H

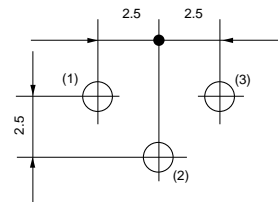

(Tolerance:±0.1 in mm)

PVC6M/PVC6Q

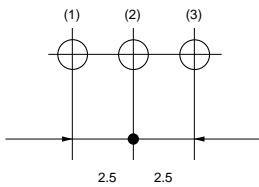

(Tolerance:±0.1 in mm)

PVC6G

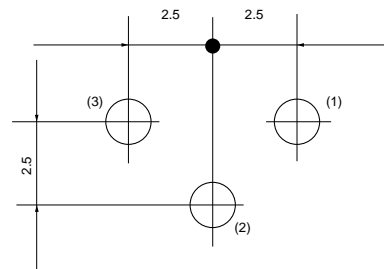

(Tolerance:±0.1 in mm)

Continued on the following page. ↗

☐ Continued from the preceding page.

## ■ Characteristics

Temperature Cycle	$\Delta$ TR	$\pm 2\%$
	$\Delta$ V.S.S.	$\pm 1\%$
Humidity	$\Delta$ TR	$\pm 2\%$
	$\Delta$ V.S.S.	$\pm 1\%$
	IR	100Mohm min.
Vibration (20G)	$\Delta$ TR	$\pm 1\%$
	$\Delta$ V.S.S.	$\pm 1\%$
Shock (100G)	$\Delta$ TR	$\pm 1\%$
	$\Delta$ V.S.S.	$\pm 1\%$
Temperature Load Life	$\Delta$ TR	$\pm 2\%$
	$\Delta$ V.S.S.	$\pm 2\%$
Low Temperature Exposure	$\Delta$ TR	$\pm 2\%$
	$\Delta$ V.S.S.	$\pm 1\%$
High Temperature Exposure	$\Delta$ TR	$\pm 2\%$
	$\Delta$ V.S.S.	$\pm 1\%$
Rotational Life (200 cycles)	$\Delta$ TR	$\pm 4\%$

$\Delta$ TR : Total Resistance Change  
 $\Delta$ V.S.S. : Voltage Setting Stability  
 IR : Insulation Resistance

## PV32 Series

### ■ Features

1. 6 standard terminal styles
2. Round shaped body enables smaller area mount than same 6mm square potentiometer.
3. Sealed construction protects the interior from dust and liquid, which achieves stable performance.
4. Available for ultrasonic cleaning after soldering
5. Flammability : UL94V-0

### ■ Applications

1. HDTVs
2. Professional cameras
3. CATV
4. FAX
5. Printers
6. Sensors
7. Power supply



PV32H

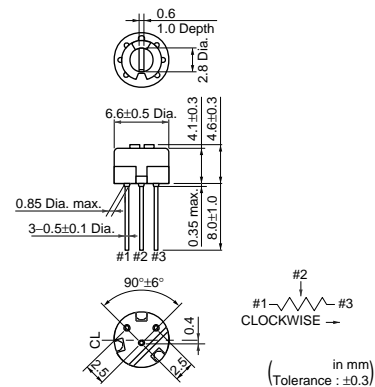

PV32R

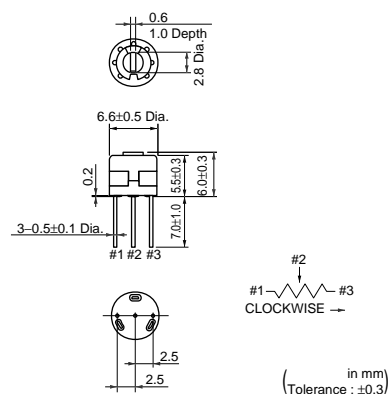

PV32P

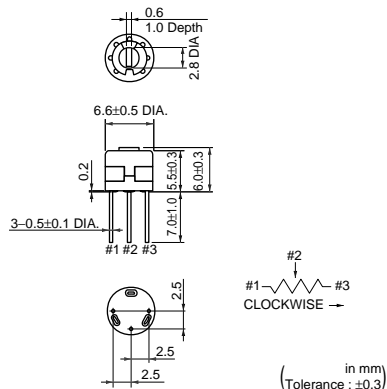

PV32N

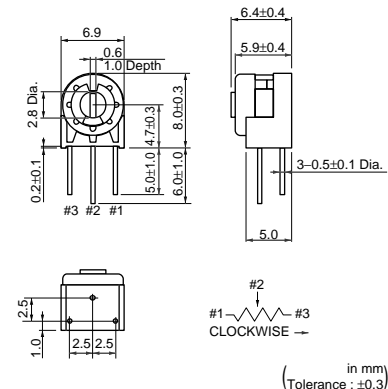

PV32S

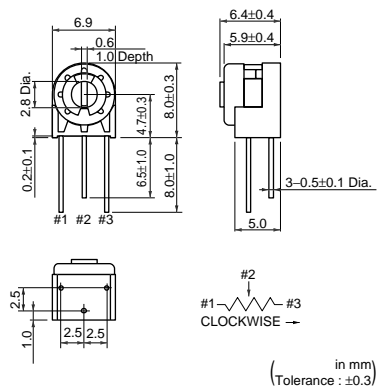

PV32T

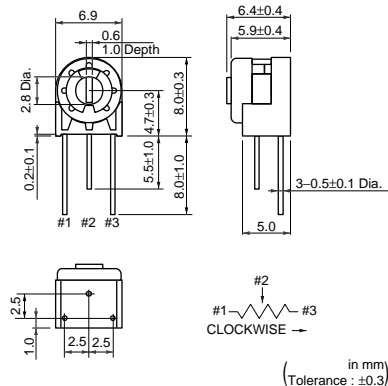

Part Number	Power Rating	Soldering Method	Number of Turns (Effective Rotation Angle)	Total Resistance Value	TCR
PV32□100A01	0.5W(70°C)	Flow/Soldering Iron	1(230°±5°)	10ohm ±20%	±100ppm/°C
PV32□200A01	0.5W(70°C)	Flow/Soldering Iron	1(230°±5°)	20ohm ±20%	±100ppm/°C
PV32□250A01	0.5W(70°C)	Flow/Soldering Iron	1(230°±5°)	25ohm ±20%	±100ppm/°C

Continued on the following page. ↗

Continued from the preceding page.

Part Number	Power Rating	Soldering Method	Number of Turns (Effective Rotation Angle)	Total Resistance Value	TCR
PV32□500A01	0.5W(70°C)	Flow/Soldering Iron	1(230°±5°)	50ohm ±20%	±100ppm/°C
PV32□101A01	0.5W(70°C)	Flow/Soldering Iron	1(230°±5°)	100ohm ±20%	±100ppm/°C
PV32□201A01	0.5W(70°C)	Flow/Soldering Iron	1(230°±5°)	200ohm ±20%	±100ppm/°C
PV32□251A01	0.5W(70°C)	Flow/Soldering Iron	1(230°±5°)	250ohm ±20%	±100ppm/°C
PV32□501A01	0.5W(70°C)	Flow/Soldering Iron	1(230°±5°)	500ohm ±20%	±100ppm/°C
PV32□102A01	0.5W(70°C)	Flow/Soldering Iron	1(230°±5°)	1k ohm ±20%	±100ppm/°C
PV32□202A01	0.5W(70°C)	Flow/Soldering Iron	1(230°±5°)	2k ohm ±20%	±100ppm/°C
PV32□252A01	0.5W(70°C)	Flow/Soldering Iron	1(230°±5°)	2.5k ohm ±20%	±100ppm/°C
PV32□502A01	0.5W(70°C)	Flow/Soldering Iron	1(230°±5°)	5k ohm ±20%	±100ppm/°C
PV32□103A01	0.5W(70°C)	Flow/Soldering Iron	1(230°±5°)	10k ohm ±20%	±100ppm/°C
PV32□203A01	0.5W(70°C)	Flow/Soldering Iron	1(230°±5°)	20k ohm ±20%	±100ppm/°C
PV32□253A01	0.5W(70°C)	Flow/Soldering Iron	1(230°±5°)	25k ohm ±20%	±100ppm/°C
PV32□503A01	0.5W(70°C)	Flow/Soldering Iron	1(230°±5°)	50k ohm ±20%	±100ppm/°C
PV32□104A01	0.5W(70°C)	Flow/Soldering Iron	1(230°±5°)	100k ohm ±20%	±100ppm/°C
PV32□204A01	0.5W(70°C)	Flow/Soldering Iron	1(230°±5°)	200k ohm ±20%	±100ppm/°C
PV32□254A01	0.5W(70°C)	Flow/Soldering Iron	1(230°±5°)	250k ohm ±20%	±100ppm/°C
PV32□504A01	0.5W(70°C)	Flow/Soldering Iron	1(230°±5°)	500k ohm ±20%	±100ppm/°C
PV32□105A01	0.5W(70°C)	Flow/Soldering Iron	1(230°±5°)	1M ohm ±20%	±100ppm/°C
PV32□205A01	0.5W(70°C)	Flow/Soldering Iron	1(230°±5°)	2M ohm ±20%	±100ppm/°C
PV32□505A01	0.5W(70°C)	Flow/Soldering Iron	1(230°±5°)	5M ohm ±20%	±100ppm/°C

Operating Temperature Range: -55 to 125 °C

The blank column is filled with the code of adjustment direction and lead type (H, P, R, N, S and T).

The order quantity should be an integral multiple of the "Minimum Quantity".

## Construction

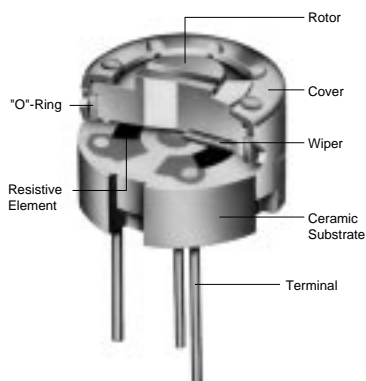

## Mounting Holes

PV32H

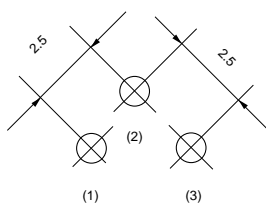

(Tolerance:±0.1 in mm)

PV32R

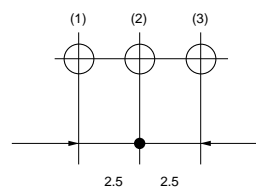

(Tolerance:±0.1 in mm)

Continued on the following page. ↗



Continued from the preceding page.

## ■ Mounting Holes

PV32P/PV32S

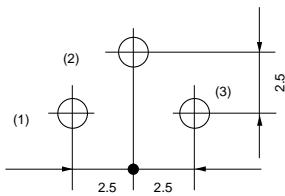

(Tolerance:±0.1  
in mm)

PV32N

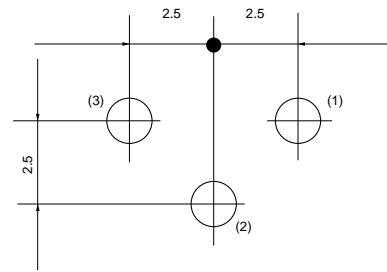

(Tolerance ±0.1  
in mm)

PV32T

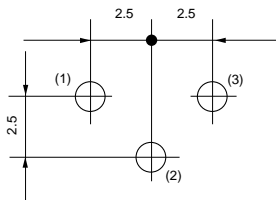

(Tolerance:±0.1  
in mm)

## ■ Characteristics

Temperature Cycle	$\Delta$ TR	±2%
	$\Delta$ V.S.S.	±1%
Humidity	$\Delta$ TR	±2%
	IR	100Mohm min.
Vibration (20G)	$\Delta$ TR	±1%
	$\Delta$ V.S.S.	±1%
Shock (100G)	$\Delta$ TR	±1%
	$\Delta$ V.S.S.	±1%
Temperature Load Life	$\Delta$ TR	±2%
	$\Delta$ V.S.S.	±2%
Low Temperature Exposure	$\Delta$ TR	±2%
	$\Delta$ V.S.S.	±1%
High Temperature Exposure	$\Delta$ TR	±2%
	$\Delta$ V.S.S.	±1%
Rotational Life (200 cycles)	$\Delta$ TR	±4%

$\Delta$ TR : Total Resistance Change  
 $\Delta$ V.S.S. : Voltage Setting Stability  
IR : Insulation Resistance

## PV34 Series

### ■ Features

1. 5 standard terminal styles
2. Sealed construction protects the interior from dust and liquid, which achieves stable performance.
3. Available for ultrasonic cleaning after soldering
4. Flammability : UL94V-0
5. To be complied with RoHS directive by new Cd free cermet resistive material. Pb free terminals with Sn plating.

### ■ Applications

1. HDTVs
2. Professional cameras
3. CATV
4. Printers
5. Sensors
6. Switching power supplies



PV34F

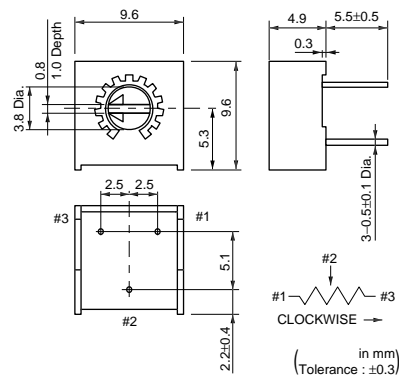

PV34H

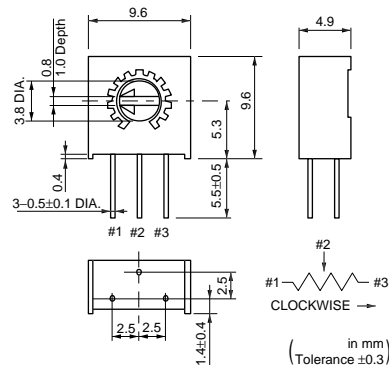

PV34P

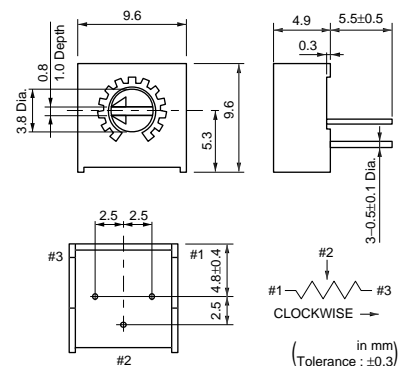

PV34W

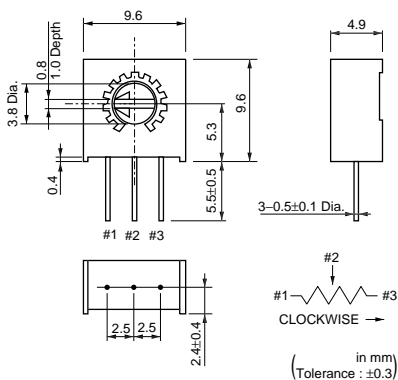

PV34X

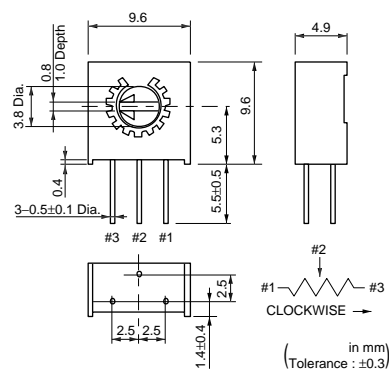

Part Number	Power Rating	Soldering Method	Number of Turns (Effective Rotation Angle)	Total Resistance Value	TCR
PV34□100C01	0.5W(70°C)	Flow/Soldering Iron	1(280°±15°)	10ohm ±10%	±150ppm/°C
PV34□200C01	0.5W(70°C)	Flow/Soldering Iron	1(280°±15°)	20ohm ±10%	±150ppm/°C
PV34□500C01	0.5W(70°C)	Flow/Soldering Iron	1(280°±15°)	50ohm ±10%	±150ppm/°C

Continued on the following page.

Continued from the preceding page.

Part Number	Power Rating	Soldering Method	Number of Turns (Effective Rotation Angle)	Total Resistance Value	TCR
PV34□101C01	0.5W(70°C)	Flow/Soldering Iron	1(280°±15°)	100ohm ±10%	±150ppm/°C
PV34□201C01	0.5W(70°C)	Flow/Soldering Iron	1(280°±15°)	200ohm ±10%	±100ppm/°C
PV34□501C01	0.5W(70°C)	Flow/Soldering Iron	1(280°±15°)	500ohm ±10%	±100ppm/°C
PV34□102C01	0.5W(70°C)	Flow/Soldering Iron	1(280°±15°)	1k ohm ±10%	±100ppm/°C
PV34□202C01	0.5W(70°C)	Flow/Soldering Iron	1(280°±15°)	2k ohm ±10%	±100ppm/°C
PV34□502C01	0.5W(70°C)	Flow/Soldering Iron	1(280°±15°)	5k ohm ±10%	±100ppm/°C
PV34□103C01	0.5W(70°C)	Flow/Soldering Iron	1(280°±15°)	10k ohm ±10%	±100ppm/°C
PV34□203C01	0.5W(70°C)	Flow/Soldering Iron	1(280°±15°)	20k ohm ±10%	±100ppm/°C
PV34□253C01	0.5W(70°C)	Flow/Soldering Iron	1(280°±15°)	25k ohm ±10%	±100ppm/°C
PV34□503C01	0.5W(70°C)	Flow/Soldering Iron	1(280°±15°)	50k ohm ±10%	±100ppm/°C
PV34□104C01	0.5W(70°C)	Flow/Soldering Iron	1(280°±15°)	100k ohm ±10%	±100ppm/°C
PV34□204C01	0.5W(70°C)	Flow/Soldering Iron	1(280°±15°)	200k ohm ±10%	±100ppm/°C
PV34□254C01	0.5W(70°C)	Flow/Soldering Iron	1(280°±15°)	250k ohm ±10%	±100ppm/°C
PV34□504C01	0.5W(70°C)	Flow/Soldering Iron	1(280°±15°)	500k ohm ±10%	±100ppm/°C
PV34□105C01	0.5W(70°C)	Flow/Soldering Iron	1(280°±15°)	1M ohm ±10%	±100ppm/°C
PV34□205C01	0.5W(70°C)	Flow/Soldering Iron	1(280°±15°)	2M ohm ±10%	±100ppm/°C

Operating Temperature Range: -55 to 125 °C

The blank column is filled with the code of adjustment direction and lead type (F, H, P, X and W).

The order quantity should be an integral multiple of the "Minimum Quantity".

Part Number	Power Rating (W)	Soldering Method	Number of Turns (Effective Rotation Angle)	Total Resistance Value	TCR (ppm/°C)	Remarks
PV34□100A01	0.5(70°C)	Flow/Soldering Iron	1(280°±15°)	10 ohm±10%	±100	Non Standard Product (Cd included)
PV34□200A01	0.5(70°C)	Flow/Soldering Iron	1(280°±15°)	20 ohm±10%	±100	
PV34□500A01	0.5(70°C)	Flow/Soldering Iron	1(280°±15°)	50 ohm±10%	±100	
PV34□101A01	0.5(70°C)	Flow/Soldering Iron	1(280°±15°)	100 ohm±10%	±100	
PV34□201A01	0.5(70°C)	Flow/Soldering Iron	1(280°±15°)	200 ohm±10%	±100	
PV34□501A01	0.5(70°C)	Flow/Soldering Iron	1(280°±15°)	500 ohm±10%	±100	
PV34□102A01	0.5(70°C)	Flow/Soldering Iron	1(280°±15°)	1k ohm±10%	±100	
PV34□202A01	0.5(70°C)	Flow/Soldering Iron	1(280°±15°)	2k ohm±10%	±100	
PV34□502A01	0.5(70°C)	Flow/Soldering Iron	1(280°±15°)	5k ohm±10%	±100	
PV34□103A01	0.5(70°C)	Flow/Soldering Iron	1(280°±15°)	10k ohm±10%	±100	
PV34□203A01	0.5(70°C)	Flow/Soldering Iron	1(280°±15°)	20k ohm±10%	±100	
PV34□253A01	0.5(70°C)	Flow/Soldering Iron	1(280°±15°)	25k ohm±10%	±100	
PV34□503A01	0.5(70°C)	Flow/Soldering Iron	1(280°±15°)	50k ohm±10%	±100	
PV34□104A01	0.5(70°C)	Flow/Soldering Iron	1(280°±15°)	100k ohm±10%	±100	
PV34□204A01	0.5(70°C)	Flow/Soldering Iron	1(280°±15°)	200k ohm±10%	±100	
PV34□254A01	0.5(70°C)	Flow/Soldering Iron	1(280°±15°)	250k ohm±10%	±100	
PV34□504A01	0.5(70°C)	Flow/Soldering Iron	1(280°±15°)	500k ohm±10%	±100	
PV34□105A01	0.5(70°C)	Flow/Soldering Iron	1(280°±15°)	1M ohm±10%	±100	
PV34□205A01	0.5(70°C)	Flow/Soldering Iron	1(280°±15°)	2M ohm±10%	±100	

## Construction

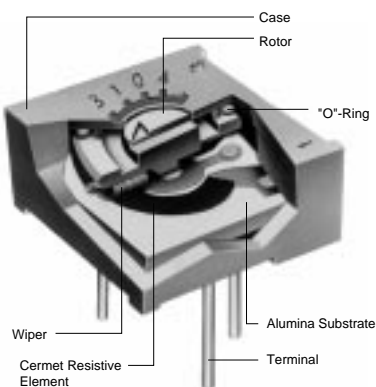

## ■ Mounting Holes

PV34F

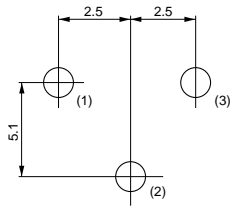

(Tolerance:±0.1  
in mm)

PV34H/PV34P

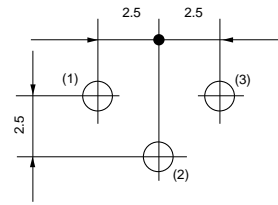

(Tolerance:±0.1  
in mm)

PV34W

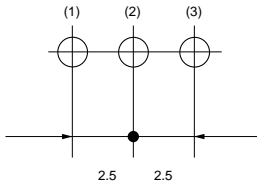

(Tolerance:±0.1  
in mm)

PV34X

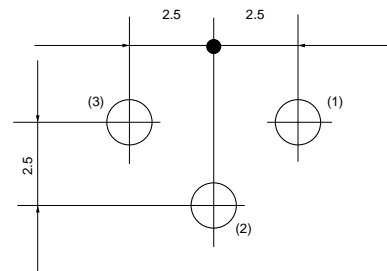

(Tolerance:±0.1  
in mm)

## ■ Characteristics

Temperature Cycle	$\Delta TR$	±2%
	$\Delta V.S.S.$	±1%
Humidity	$\Delta TR$	±2%
	IR	100Mohm min.
Vibration (20G)	$\Delta TR$	±1%
	$\Delta V.S.S.$	±1%
Shock (100G)	$\Delta TR$	±1%
	$\Delta V.S.S.$	±1%
Temperature Load Life	$\Delta TR$	±2%
	$\Delta V.S.S.$	±2%
Low Temperature Exposure	$\Delta TR$	±1%
	$\Delta V.S.S.$	±1%
High Temperature Exposure	$\Delta TR$	±2%
	$\Delta V.S.S.$	±1%
Rotational Life (200 cycles)	$\Delta TR$	R≤100kohm ... ±3%
		R>100kohm ... ±5%

$\Delta TR$  : Total Resistance Change  
 $\Delta V.S.S.$  : Voltage Setting Stability  
 IR : Insulation Resistance  
 R : Standard Total Resistance

## PVC6/PV32/PV34 Series Notice

### ■ Notice (Operating and Storage Conditions)

1. Store in temperatures of -10 to +40 deg. C and relative humidity of 30-85%RH.
2. Do not store in or near corrosive gases.
3. Use within six months after delivery.
4. Open the package just before using.
5. Do not store under direct sunlight.
6. If you use the trimmer potentiometer in an environment other than listed below, please consult with a Murata factory representative prior to using.  
The trimmer potentiometer should not be used under

- the following environmental conditions:
- (1) Corrosive gaseous atmosphere  
(Ex. Chlorine gas, Hydrogen sulfide gas, Ammonia gas, Sulfuric acid gas, Nitric oxide gas, etc.)
  - (2) In liquid  
(Ex. Oil, Medical liquid, Organic solvent, etc.)
  - (3) Dusty / dirty atmosphere
  - (4) Direct sunlight
  - (5) Static voltage nor electric/magnetic fields
  - (6) Direct sea breeze
  - (7) Other variations of the above

### ■ Notice (Rating)

1. When using with partial load (rheostat), minimize the power depending on the resistance value.
2. The maximum input voltage to a trimmer potentiometer should not exceed  $(P.R)^{1/2}$  or the maximum operating voltage, whichever is smaller.
3. The maximum input current to a trimmer potentiometer should not exceed  $(P/R)^{1/2}$  or the allowable wiper current, whichever is smaller.

### ■ Notice (Soldering and Mounting)

#### 1. Soldering

##### (1) Standard soldering condition

###### (a) Flow soldering :

- >Pre-heating temp. 80-100 deg. C
- >Soldering temp. 260 deg. C max.
- >Soldering time 3 sec. max.

###### (b) Soldering iron :

- >Temperature of tip 300 deg. C max.
- >Soldering time 3 sec. max.
- >Wattage of iron 40W max.

Before using other soldering conditions than those listed above, please consult with Murata factory representative prior to using. If the soldering conditions are not suitable, e.g., excessive time and/or excessive temperature, the trimmer potentiometer may deviate from the specified characteristics.

- (2) To minimize mechanical stress when adjusting, the trimmer potentiometer should be mounted onto PCB without gap.
  - (3) The soldering iron should not come in contact with the case of the trimmer potentiometer. If such contact does occur, the trimmer potentiometer may be damaged.
- #### 2. Mounting
- (1) Use PCB hole to meet the pin of the trimmer potentiometer. If the trimmer potentiometer installs into insufficient PCB hole, the

trimmer potentiometer may be damaged by mechanical stress.

- (2) Do not apply excessive force (preferably 9.8N (Ref.: 1kgf) max.), when the trimmer potentiometer is mounted to the PCB.

#### 3. Cleaning

- (1) Isopropyl-alcohol and Ethyl-alcohol are applicable solvents for cleaning. If you use any other types of solvents, please consult with a Murata factory representative prior to using.
- (2) The total cleaning time by cold dipping, vapor and ultrasonic washing (conditions as below) method should be less than 3 minutes.
- (3) For ultra-sonic cleaning, the available condition is as follows.
  - >Power: 600W (67 liter) max.
  - >Frequency: 28kHz
  - >Temperature: Ambient temperature

Due to the ultra-sonic cleaning equipment's peculiar self-resonance point and that the cleaning compatibility usually depends on the jig construction and/or the cleaning condition such as the depth of immersion, please check the cleaning equipment to determine the suitable conditions.

If the trimmer potentiometer is cleaned by other conditions, the trimmer potentiometer may be damaged.

## PVC6/PV32/PV34 Series Notice

### ■ Notice (Handling)

1. Use suitable screwdrivers that fit comfortably in driver slot. We recommend the screwdrivers below.

\* Recommended screwdriver for manual adjustment

<PVC6 series>

VESSEL MFG. : NO.9000+0x30

(Murata P/N : KMDR150)

TORAY INDUSTRIES, INC. : SA-2225

(Murata P/N : KMDR070)

<PV32/34 series>

ENGINEER INC. : DA-40

(Murata P/N : KMDR180)

\* Recommended screwdriver bit for automatic adjustment

<PVC6 series>

VESSEL MFG. : NO.CA-10

(Murata P/N : KMBT090)

TORAY INDUSTRIES, INC. : JB-2225

(Murata P/N : KMBT070)

We can supply the screwdrivers above.

If you place an order, please specify the Murata P/N.

2. Don't apply more than 9.8N (Ref.; 1kgf) of twist and stress after mounting onto PCB to prevent contact intermittence. If excessive force is applied, the trimmer potentiometer may not function.
3. When adjusting with an adjustment tool, the applied force to the adjustment screw should not exceed 4.9N (Ref.; 500gf). If excessive force is applied, the trimmer potentiometer may not function due to damage.
4. The rotational torque at the position of the adjustment range should not exceed the stop strength.
5. When using a lock paint to fix slot position, please use adhesive resin without chlorine or sulfur (Three-bond "1401 series").

### ■ Notice (Other)

1. Please make sure that your product has been evaluated and confirmed against your specifications when our product is mounted to your product.
2. Murata cannot guarantee trimmer potentiometer integrity when used under conditions other than those specified in this document.

# Trimmer Potentiometers



## Lead Sealed Type Multi-turns PV12/PV37/PV23/PV22/PV36 Series

### PV12 Series

#### ■ Features

1. The unique inner gear system recognizes the position of the center of the shaft of the potentiometer.
2. Sealed construction protects the interior from dust and liquid, which achieves stable performance.
3. Available for ultrasonic cleaning after soldering
4. Clutch mechanism prevents excessive wiper rotation.

#### ■ Applications

1. HDTVs
2. Professional cameras
3. CATV
4. FAX
5. Printers
6. Sensors
7. Switching power supplies



PV12H

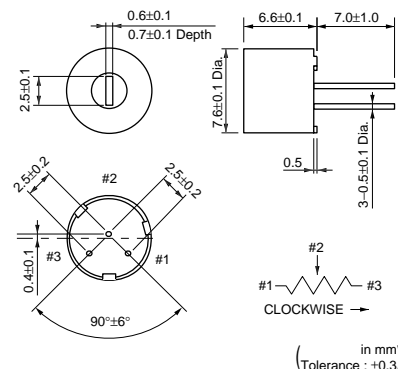

PV12P

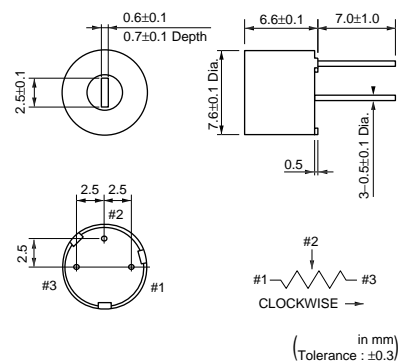

PV12S

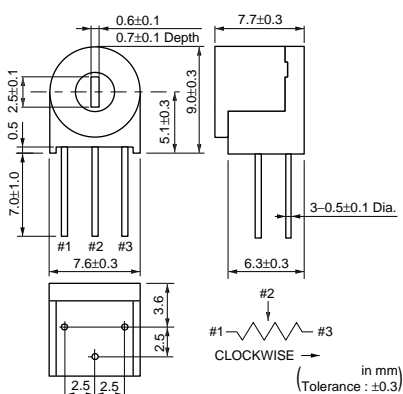

PV12T

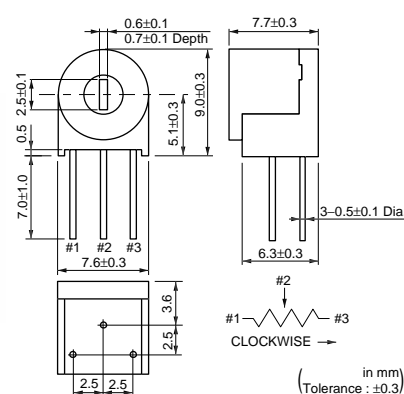

Part Number	Power Rating	Soldering Method	Number of Turns (Effective Rotation Angle)	Total Resistance Value	TCR
PV12□100A01	0.5W(70°C)	Flow/Soldering Iron	4	10ohm ±10%	±100ppm/°C
PV12□200A01	0.5W(70°C)	Flow/Soldering Iron	4	20ohm ±10%	±100ppm/°C
PV12□500A01	0.5W(70°C)	Flow/Soldering Iron	4	50ohm ±10%	±100ppm/°C
PV12□101A01	0.5W(70°C)	Flow/Soldering Iron	4	100ohm ±10%	±100ppm/°C
PV12□201A01	0.5W(70°C)	Flow/Soldering Iron	4	200ohm ±10%	±100ppm/°C
PV12□501A01	0.5W(70°C)	Flow/Soldering Iron	4	500ohm ±10%	±100ppm/°C
PV12□102A01	0.5W(70°C)	Flow/Soldering Iron	4	1k ohm ±10%	±100ppm/°C
PV12□202A01	0.5W(70°C)	Flow/Soldering Iron	4	2k ohm ±10%	±100ppm/°C
PV12□502A01	0.5W(70°C)	Flow/Soldering Iron	4	5k ohm ±10%	±100ppm/°C
PV12□103A01	0.5W(70°C)	Flow/Soldering Iron	4	10k ohm ±10%	±100ppm/°C

Continued on the following page.

Continued from the preceding page.

Part Number	Power Rating	Soldering Method	Number of Turns (Effective Rotation Angle)	Total Resistance Value	TCR
PV12□203A01	0.5W(70°C)	Flow/Soldering Iron	4	20k ohm ±10%	±100ppm/°C
PV12□503A01	0.5W(70°C)	Flow/Soldering Iron	4	50k ohm ±10%	±100ppm/°C
PV12□104A01	0.5W(70°C)	Flow/Soldering Iron	4	100k ohm ±10%	±100ppm/°C
PV12□204A01	0.5W(70°C)	Flow/Soldering Iron	4	200k ohm ±10%	±100ppm/°C
PV12□504A01	0.5W(70°C)	Flow/Soldering Iron	4	500k ohm ±10%	±100ppm/°C
PV12□105A01	0.5W(70°C)	Flow/Soldering Iron	4	1M ohm ±10%	±100ppm/°C
PV12□205A01	0.5W(70°C)	Flow/Soldering Iron	4	2M ohm ±10%	±100ppm/°C

Operating Temperature Range: -55 to 125 °C

The blank column is filled with the code of adjustment direction and lead type (H, P, T and S).

The order quantity should be an integral multiple of the "Minimum Quantity".

## Construction

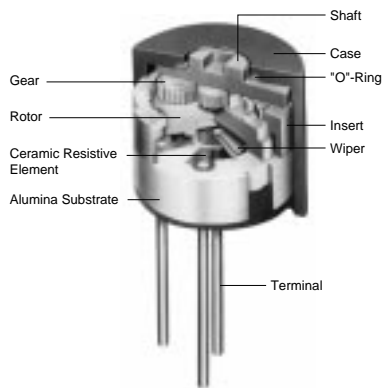

## Mounting Holes

PV12H

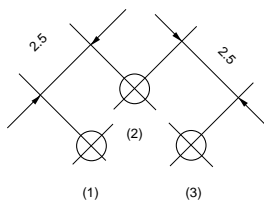

(Tolerance:±0.1  
in mm)

PV12P/PV12S

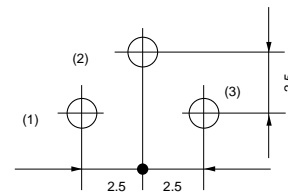

(Tolerance:±0.1  
in mm)

PV12T

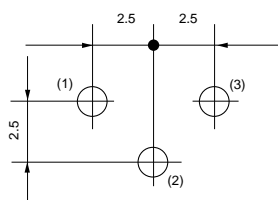

(Tolerance:±0.1  
in mm)



## ■ Characteristics

Temperature Cycle	$\Delta$ TR	$\pm 2\%$
	$\Delta$ V.S.S.	$\pm 1\%$
Humidity	$\Delta$ TR	$\pm 2\%$
	IR	100Mohm min.
Vibration (20G)	$\Delta$ TR	$\pm 1\%$
	$\Delta$ V.S.S.	$\pm 1\%$
Shock (100G)	$\Delta$ TR	$\pm 1\%$
	$\Delta$ V.S.S.	$\pm 1\%$
Temperature Load Life	$\Delta$ TR	$\pm 3\%$
	$\Delta$ V.S.S.	$\pm 2\%$
Low Temperature Exposure	$\Delta$ TR	$\pm 3\%$
	$\Delta$ V.S.S.	$\pm 1.5\%$
High Temperature Exposure	$\Delta$ TR	$\pm 3\%$
	$\Delta$ V.S.S.	$\pm 1.5\%$
Rotational Life (200 cycles)	$\Delta$ TR	$\pm 3\%$

$\Delta$ TR : Total Resistance Change  
 $\Delta$ V.S.S. : Voltage Setting Stability  
 IR : Insulation Resistance

## PV37 Series

### ■ Features

1. Smaller volume (about one-third) than 25-turns potentiometer
2. Sealed construction protects the interior from dust and liquid, which achieves stable performance.
3. Available for ultrasonic cleaning after soldering
4. Clutch mechanism prevents excessive wiper rotation.
5. 5 standard terminal styles
6. Both Top and side adjustment directions
7. To be complied with RoHS directive by new Cd free cermet resistive material. Pb free terminals with Sn plating.

### ■ Applications

1. Measuring instruments
2. OA equipment
3. Medical equipment
4. Power supply
5. Base station for cellular phone



PV37P

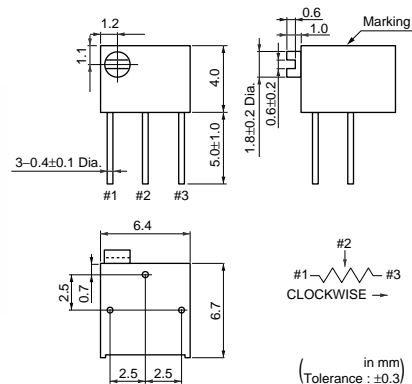

PV37W

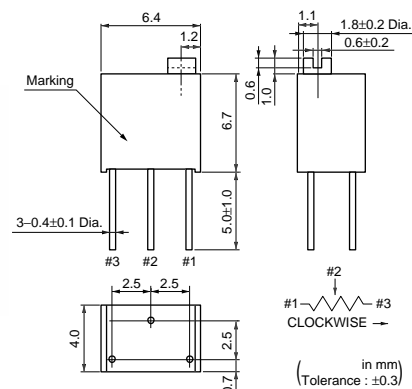

PV37X

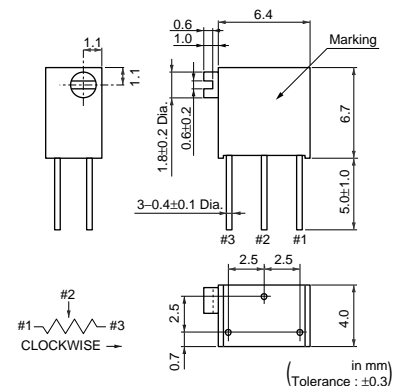

PV37Y

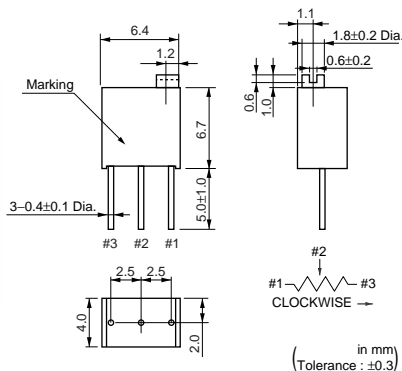

PV37Z

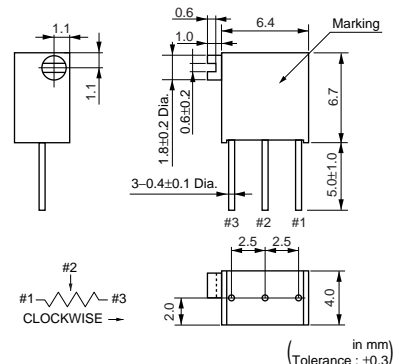

Part Number	Power Rating	Soldering Method	Number of Turns (Effective Rotation Angle)	Total Resistance Value	TCR
PV37□100C01	0.25W(85°C)	Flow/Soldering Iron	12	10ohm ±10%	±150ppm/°C
PV37□200C01	0.25W(85°C)	Flow/Soldering Iron	12	20ohm ±10%	±150ppm/°C
PV37□500C01	0.25W(85°C)	Flow/Soldering Iron	12	50ohm ±10%	±150ppm/°C

Continued on the following page. ↗

Continued from the preceding page.

Part Number	Power Rating	Soldering Method	Number of Turns (Effective Rotation Angle)	Total Resistance Value	TCR
PV37□101C01	0.25W(85°C)	Flow/Soldering Iron	12	100ohm ±10%	±150ppm/°C
PV37□201C01	0.25W(85°C)	Flow/Soldering Iron	12	200ohm ±10%	±150ppm/°C
PV37□501C01	0.25W(85°C)	Flow/Soldering Iron	12	500ohm ±10%	±150ppm/°C
PV37□102C01	0.25W(85°C)	Flow/Soldering Iron	12	1k ohm ±10%	±150ppm/°C
PV37□202C01	0.25W(85°C)	Flow/Soldering Iron	12	2k ohm ±10%	±150ppm/°C
PV37□502C01	0.25W(85°C)	Flow/Soldering Iron	12	5k ohm ±10%	±150ppm/°C
PV37□103C01	0.25W(85°C)	Flow/Soldering Iron	12	10k ohm ±10%	±150ppm/°C
PV37□203C01	0.25W(85°C)	Flow/Soldering Iron	12	20k ohm ±10%	±150ppm/°C
PV37□253C01	0.25W(85°C)	Flow/Soldering Iron	12	25k ohm ±10%	±150ppm/°C
PV37□503C01	0.25W(85°C)	Flow/Soldering Iron	12	50k ohm ±10%	±150ppm/°C
PV37□104C01	0.25W(85°C)	Flow/Soldering Iron	12	100k ohm ±10%	±150ppm/°C
PV37□204C01	0.25W(85°C)	Flow/Soldering Iron	12	200k ohm ±10%	±150ppm/°C
PV37□254C01	0.25W(85°C)	Flow/Soldering Iron	12	250k ohm ±10%	±150ppm/°C
PV37□504C01	0.25W(85°C)	Flow/Soldering Iron	12	500k ohm ±10%	±150ppm/°C
PV37□105C01	0.25W(85°C)	Flow/Soldering Iron	12	1M ohm ±10%	±150ppm/°C
PV37□205C01	0.25W(85°C)	Flow/Soldering Iron	12	2M ohm ±10%	±150ppm/°C
PV37□100C31	0.25W(85°C)	Flow/Soldering Iron	12	10ohm ±10%	±150ppm/°C
PV37□200C31	0.25W(85°C)	Flow/Soldering Iron	12	20ohm ±10%	±150ppm/°C
PV37□500C31	0.25W(85°C)	Flow/Soldering Iron	12	50ohm ±10%	±150ppm/°C
PV37□101C31	0.25W(85°C)	Flow/Soldering Iron	12	100ohm ±10%	±150ppm/°C
PV37□201C31	0.25W(85°C)	Flow/Soldering Iron	12	200ohm ±10%	±150ppm/°C
PV37□501C31	0.25W(85°C)	Flow/Soldering Iron	12	500ohm ±10%	±150ppm/°C
PV37□102C31	0.25W(85°C)	Flow/Soldering Iron	12	1k ohm ±10%	±150ppm/°C
PV37□202C31	0.25W(85°C)	Flow/Soldering Iron	12	2k ohm ±10%	±150ppm/°C
PV37□502C31	0.25W(85°C)	Flow/Soldering Iron	12	5k ohm ±10%	±150ppm/°C
PV37□103C31	0.25W(85°C)	Flow/Soldering Iron	12	10k ohm ±10%	±150ppm/°C
PV37□203C31	0.25W(85°C)	Flow/Soldering Iron	12	20k ohm ±10%	±150ppm/°C
PV37□253C31	0.25W(85°C)	Flow/Soldering Iron	12	25k ohm ±10%	±150ppm/°C
PV37□503C31	0.25W(85°C)	Flow/Soldering Iron	12	50k ohm ±10%	±150ppm/°C
PV37□104C31	0.25W(85°C)	Flow/Soldering Iron	12	100k ohm ±10%	±150ppm/°C
PV37□204C31	0.25W(85°C)	Flow/Soldering Iron	12	200k ohm ±10%	±150ppm/°C
PV37□254C31	0.25W(85°C)	Flow/Soldering Iron	12	250k ohm ±10%	±150ppm/°C
PV37□504C31	0.25W(85°C)	Flow/Soldering Iron	12	500k ohm ±10%	±150ppm/°C
PV37□105C31	0.25W(85°C)	Flow/Soldering Iron	12	1M ohm ±10%	±150ppm/°C
PV37□205C31	0.25W(85°C)	Flow/Soldering Iron	12	2M ohm ±10%	±150ppm/°C

Operating Temperature Range: -55 to 125 °C

The blank column is filled with the code of adjustment direction and lead type (P, X, Y, W and Z).

The order quantity should be an integral multiple of the "Minimum Quantity".

The last three digits express the individual specification codes. C01 for standard type and C31 for radial taping type (PV37Y/PV37Z series only).

Part Number	Power Rating (W)	Soldering Method	Number of Turns (Effective Rotation Angle)	Total Resistance Value	TCR (ppm/°C)	Remarks
PV37□100A01	0.25(85°C)	Flow/Soldering Iron	12	10 ohm±10%	±100	Non Standard Product (Cd included)
PV37□200A01	0.25(85°C)	Flow/Soldering Iron	12	20 ohm±10%	±100	
PV37□500A01	0.25(85°C)	Flow/Soldering Iron	12	50 ohm±10%	±100	
PV37□101A01	0.25(85°C)	Flow/Soldering Iron	12	100 ohm±10%	±100	
PV37□201A01	0.25(85°C)	Flow/Soldering Iron	12	200 ohm±10%	±100	
PV37□501A01	0.25(85°C)	Flow/Soldering Iron	12	500 ohm±10%	±100	
PV37□102A01	0.25(85°C)	Flow/Soldering Iron	12	1k ohm±10%	±100	
PV37□202A01	0.25(85°C)	Flow/Soldering Iron	12	2k ohm±10%	±100	
PV37□502A01	0.25(85°C)	Flow/Soldering Iron	12	5k ohm±10%	±100	
PV37□103A01	0.25(85°C)	Flow/Soldering Iron	12	10k ohm±10%	±100	
PV37□203A01	0.25(85°C)	Flow/Soldering Iron	12	20k ohm±10%	±100	
PV37□253A01	0.25(85°C)	Flow/Soldering Iron	12	25k ohm±10%	±100	
PV37□503A01	0.25(85°C)	Flow/Soldering Iron	12	50k ohm±10%	±100	
PV37□104A01	0.25(85°C)	Flow/Soldering Iron	12	100k ohm±10%	±100	
PV37□204A01	0.25(85°C)	Flow/Soldering Iron	12	200k ohm±10%	±100	
PV37□254A01	0.25(85°C)	Flow/Soldering Iron	12	250k ohm±10%	±100	
PV37□504A01	0.25(85°C)	Flow/Soldering Iron	12	500k ohm±10%	±100	
PV37□105A01	0.25(85°C)	Flow/Soldering Iron	12	1M ohm±10%	±100	
PV37□205A01	0.25(85°C)	Flow/Soldering Iron	12	2M ohm±10%	±100	
PV37□100A31	0.25(85°C)	Flow/Soldering Iron	12	10 ohm±10%	±100	
PV37□200A31	0.25(85°C)	Flow/Soldering Iron	12	20 ohm±10%	±100	
PV37□500A31	0.25(85°C)	Flow/Soldering Iron	12	50 ohm±10%	±100	
PV37□101A31	0.25(85°C)	Flow/Soldering Iron	12	100 ohm±10%	±100	
PV37□201A31	0.25(85°C)	Flow/Soldering Iron	12	200 ohm±10%	±100	
PV37□501A31	0.25(85°C)	Flow/Soldering Iron	12	500 ohm±10%	±100	
PV37□102A31	0.25(85°C)	Flow/Soldering Iron	12	1k ohm±10%	±100	
PV37□202A31	0.25(85°C)	Flow/Soldering Iron	12	2k ohm±10%	±100	
PV37□502A31	0.25(85°C)	Flow/Soldering Iron	12	5k ohm±10%	±100	
PV37□103A31	0.25(85°C)	Flow/Soldering Iron	12	10k ohm±10%	±100	
PV37□203A31	0.25(85°C)	Flow/Soldering Iron	12	20k ohm±10%	±100	
PV37□253A31	0.25(85°C)	Flow/Soldering Iron	12	25k ohm±10%	±100	
PV37□503A31	0.25(85°C)	Flow/Soldering Iron	12	50k ohm±10%	±100	
PV37□104A31	0.25(85°C)	Flow/Soldering Iron	12	100k ohm±10%	±100	
PV37□204A31	0.25(85°C)	Flow/Soldering Iron	12	200k ohm±10%	±100	
PV37□254A31	0.25(85°C)	Flow/Soldering Iron	12	250k ohm±10%	±100	
PV37□504A31	0.25(85°C)	Flow/Soldering Iron	12	500k ohm±10%	±100	
PV37□105A31	0.25(85°C)	Flow/Soldering Iron	12	1M ohm±10%	±100	
PV37□205A31	0.25(85°C)	Flow/Soldering Iron	12	2M ohm±10%	±100	

■ Construction

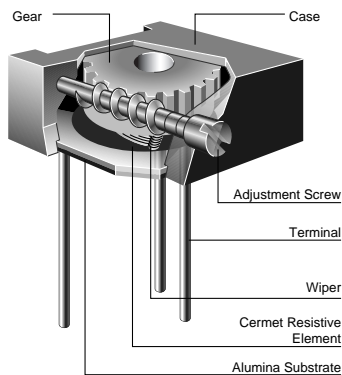

## ■ Mounting Holes

PV37P

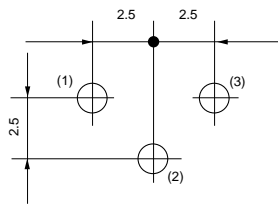

(Tolerance:±0.1  
in mm)

PV37W/PV37X

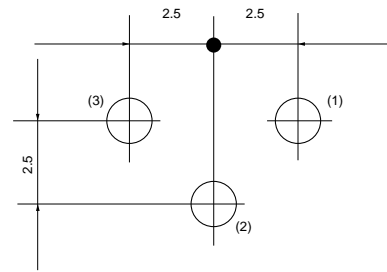

(Tolerance ±0.1  
in mm)

PV37Y/PV37Z

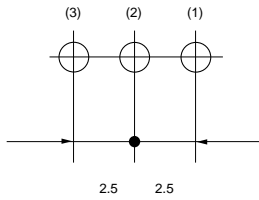

(Tolerance:±0.1  
in mm)

## ■ Characteristics

Temperature Cycle	$\Delta TR$	±1%
	$\Delta V.S.S.$	±1%
Humidity	$\Delta TR$	±2%
	IR	100Mohm min.
Vibration (20G)	$\Delta TR$	±1%
	$\Delta V.S.S.$	±1%
Shock (100G)	$\Delta TR$	±1%
	$\Delta V.S.S.$	±1%
Temperature Load Life	$\Delta TR$	±2%
	$\Delta V.S.S.$	±1%
Low Temperature Exposure	$\Delta TR$	±1%
	$\Delta V.S.S.$	±1%
High Temperature Exposure	$\Delta TR$	±2%
	$\Delta V.S.S.$	±1%
Rotational Life (200 cycles)	$\Delta TR$	R≤100ohm ... ±3%
		R>100ohm ... ±2%

$\Delta TR$  : Total Resistance Change  
 $\Delta V.S.S.$  : Voltage Setting Stability  
 IR : Insulation Resistance  
 R : Standard Total Resistance

## PV23 Series

### ■ Features

1. Small size (4.6x6.4x19.1mm) and high power rating (0.75W at 70deg.C)
2. Sealed construction protects the interior from dust and liquid, which achieves stable performance.
3. Available for ultrasonic cleaning after soldering
4. Clutch mechanism prevents excessive wiper rotation.
5. To be complied with RoHS directive by new Cd free cermet resistive material. Pb free terminals with Sn plating.

### ■ Applications

1. Measuring instruments
2. FAX
3. Copier
4. Printers
5. Sensors



PV23P

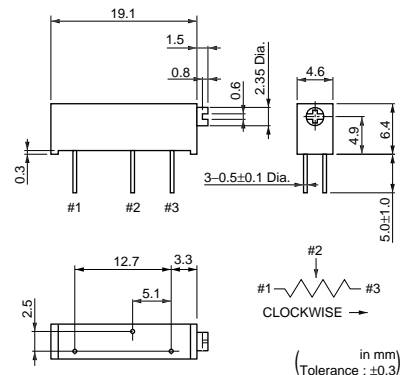

PV23Y

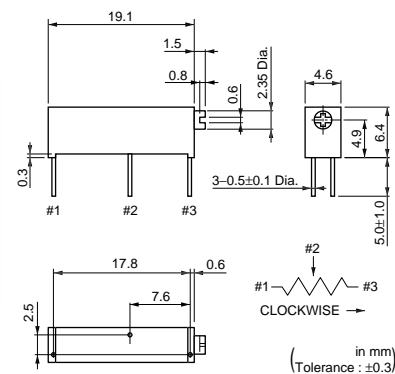

Part Number	Power Rating	Soldering Method	Number of Turns (Effective Rotation Angle)	Total Resistance Value	TCR
PV23□100C01	0.75W(70°C)	Flow/Soldering Iron	15	10ohm ±10%	±150ppm/°C
PV23□200C01	0.75W(70°C)	Flow/Soldering Iron	15	20ohm ±10%	±150ppm/°C
PV23□500C01	0.75W(70°C)	Flow/Soldering Iron	15	50ohm ±10%	±150ppm/°C
PV23□101C01	0.75W(70°C)	Flow/Soldering Iron	15	100ohm ±10%	±150ppm/°C
PV23□201C01	0.75W(70°C)	Flow/Soldering Iron	15	200ohm ±10%	±100ppm/°C
PV23□501C01	0.75W(70°C)	Flow/Soldering Iron	15	500ohm ±10%	±100ppm/°C
PV23□102C01	0.75W(70°C)	Flow/Soldering Iron	15	1k ohm ±10%	±100ppm/°C
PV23□202C01	0.75W(70°C)	Flow/Soldering Iron	15	2k ohm ±10%	±100ppm/°C
PV23□502C01	0.75W(70°C)	Flow/Soldering Iron	15	5k ohm ±10%	±100ppm/°C
PV23□103C01	0.75W(70°C)	Flow/Soldering Iron	15	10k ohm ±10%	±100ppm/°C
PV23□203C01	0.75W(70°C)	Flow/Soldering Iron	15	20k ohm ±10%	±100ppm/°C
PV23□503C01	0.75W(70°C)	Flow/Soldering Iron	15	50k ohm ±10%	±100ppm/°C
PV23□104C01	0.75W(70°C)	Flow/Soldering Iron	15	100k ohm ±10%	±100ppm/°C
PV23□204C01	0.75W(70°C)	Flow/Soldering Iron	15	200k ohm ±10%	±100ppm/°C
PV23□504C01	0.75W(70°C)	Flow/Soldering Iron	15	500k ohm ±10%	±100ppm/°C
PV23□105C01	0.75W(70°C)	Flow/Soldering Iron	15	1M ohm ±10%	±100ppm/°C
PV23□205C01	0.75W(70°C)	Flow/Soldering Iron	15	2M ohm ±10%	±100ppm/°C

Operating Temperature Range: -55 to 125 °C

The blank column is filled with the code of adjustment direction and lead type (P and Y).

The order quantity should be an integral multiple of the "Minimum Quantity".

Part Number	Power Rating (W)	Soldering Method	Number of Turns (Effective Rotation Angle)	Total Resistance Value	TCR (ppm/°C)	Remarks
PV23□100A01	0.75(70°C)	Flow/Soldering Iron	15	10 ohm±10%	±100	Non Standard Product (Cd included)
PV23□200A01	0.75(70°C)	Flow/Soldering Iron	15	20 ohm±10%	±100	
PV23□500A01	0.75(70°C)	Flow/Soldering Iron	15	50 ohm±10%	±100	
PV23□101A01	0.75(70°C)	Flow/Soldering Iron	15	100 ohm±10%	±100	
PV23□201A01	0.75(70°C)	Flow/Soldering Iron	15	200 ohm±10%	±100	
PV23□501A01	0.75(70°C)	Flow/Soldering Iron	15	500 ohm±10%	±100	
PV23□102A01	0.75(70°C)	Flow/Soldering Iron	15	1k ohm±10%	±100	
PV23□202A01	0.75(70°C)	Flow/Soldering Iron	15	2k ohm±10%	±100	
PV23□502A01	0.75(70°C)	Flow/Soldering Iron	15	5k ohm±10%	±100	
PV23□103A01	0.75(70°C)	Flow/Soldering Iron	15	10k ohm±10%	±100	
PV23□203A01	0.75(70°C)	Flow/Soldering Iron	15	20k ohm±10%	±100	
PV23□503A01	0.75(70°C)	Flow/Soldering Iron	15	50k ohm±10%	±100	
PV23□104A01	0.75(70°C)	Flow/Soldering Iron	15	100k ohm±10%	±100	
PV23□204A01	0.75(70°C)	Flow/Soldering Iron	15	200k ohm±10%	±100	
PV23□504A01	0.75(70°C)	Flow/Soldering Iron	15	500k ohm±10%	±100	
PV23□105A01	0.75(70°C)	Flow/Soldering Iron	15	1M ohm±10%	±100	
PV23□205A01	0.75(70°C)	Flow/Soldering Iron	15	2M ohm±10%	±100	

### ■ Construction

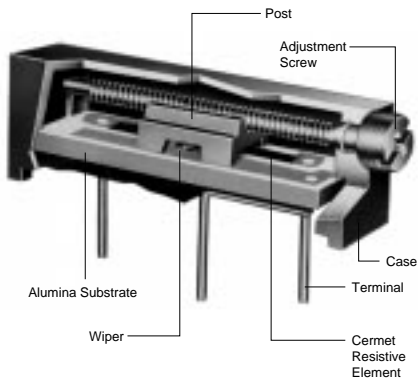

### ■ Mounting Holes

PV23P

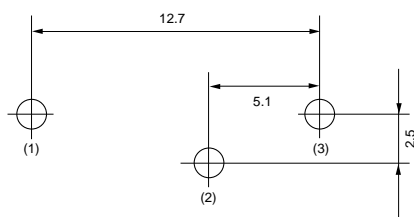

(Tolerance:±0.1 in mm)

PV23Y

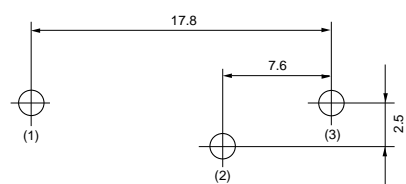

(Tolerance:±0.1 in mm)

## ■ Characteristics

Temperature Cycle	$\Delta$ TR	$\pm 2\%$
	$\Delta$ V.S.S.	$\pm 1\%$
Humidity	$\Delta$ TR	$\pm 2\%$
	IR	100Mohm min.
Vibration (20G)	$\Delta$ TR	$\pm 1\%$
	$\Delta$ V.S.S.	$\pm 1\%$
Shock (50G)	$\Delta$ TR	$\pm 1\%$
	$\Delta$ V.S.S.	$\pm 1\%$
Temperature Load Life	$\Delta$ TR	$\pm 3\%$
	$\Delta$ V.S.S.	$\pm 1\%$
Low Temperature Exposure	$\Delta$ TR	$\pm 1\%$
	$\Delta$ V.S.S.	$\pm 1\%$
High Temperature Exposure	$\Delta$ TR	$\pm 2\%$
	$\Delta$ V.S.S.	$\pm 1\%$
Rotational Life (200 cycles)	$\Delta$ TR	$\pm 3\%$

$\Delta$ TR : Total Resistance Change  
 $\Delta$ V.S.S. : Voltage Setting Stability  
 IR : Insulation Resistance



## PV22 Series

### ■ Features

1. High power rating (1W at 70 deg.C)
2. Sealed construction protects the interior from dust and liquid, which achieves stable performance.
3. Available for ultrasonic cleaning after soldering
4. Clutch mechanism prevents excessive wiper rotation.
5. To be complied with RoHS directive by new Cd free cermet resistive material. Pb free terminals with Sn plating.

### ■ Applications

1. Measuring instruments
2. FAX
3. Copier
4. Printers
5. Sensors



PV22L

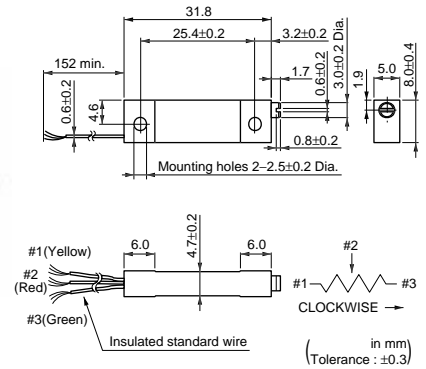

PV22S

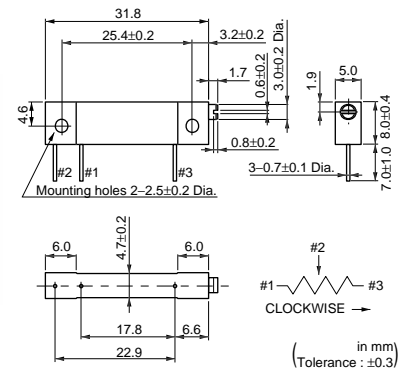

PV22Y

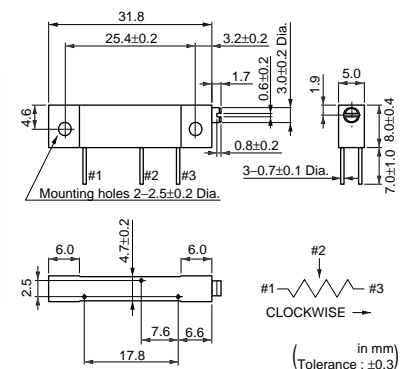

Part Number	Power Rating	Soldering Method	Number of Turns (Effective Rotation Angle)	Total Resistance Value	TCR
PV22□100C01	1.0W(70°C)	Flow/Soldering Iron	22	10ohm ±10%	±100ppm/°C
PV22□200C01	1.0W(70°C)	Flow/Soldering Iron	22	20ohm ±10%	±100ppm/°C
PV22□500C01	1.0W(70°C)	Flow/Soldering Iron	22	50ohm ±10%	±100ppm/°C
PV22□101C01	1.0W(70°C)	Flow/Soldering Iron	22	100ohm ±10%	±100ppm/°C
PV22□201C01	1.0W(70°C)	Flow/Soldering Iron	22	200ohm ±10%	±100ppm/°C
PV22□501C01	1.0W(70°C)	Flow/Soldering Iron	22	500ohm ±10%	±100ppm/°C
PV22□102C01	1.0W(70°C)	Flow/Soldering Iron	22	1k ohm ±10%	±100ppm/°C
PV22□202C01	1.0W(70°C)	Flow/Soldering Iron	22	2k ohm ±10%	±100ppm/°C
PV22□502C01	1.0W(70°C)	Flow/Soldering Iron	22	5k ohm ±10%	±100ppm/°C
PV22□103C01	1.0W(70°C)	Flow/Soldering Iron	22	10k ohm ±10%	±100ppm/°C
PV22□203C01	1.0W(70°C)	Flow/Soldering Iron	22	20k ohm ±10%	±100ppm/°C
PV22□503C01	1.0W(70°C)	Flow/Soldering Iron	22	50k ohm ±10%	±100ppm/°C
PV22□104C01	1.0W(70°C)	Flow/Soldering Iron	22	100k ohm ±10%	±100ppm/°C
PV22□204C01	1.0W(70°C)	Flow/Soldering Iron	22	200k ohm ±10%	±100ppm/°C
PV22□504C01	1.0W(70°C)	Flow/Soldering Iron	22	500k ohm ±10%	±100ppm/°C
PV22□105C01	1.0W(70°C)	Flow/Soldering Iron	22	1M ohm ±10%	±100ppm/°C

Continued on the following page. ↗

Continued from the preceding page.

Part Number	Power Rating	Soldering Method	Number of Turns (Effective Rotation Angle)	Total Resistance Value	TCR
PV22□205C01	1.0W(70°C)	Flow/Soldering Iron	22	2M ohm ±10%	±100ppm/°C

Operating Temperature Range: -55 to 150 °C

The blank column is filled with the code of adjustment direction and lead type (L, S and Y).

The order quantity should be an integral multiple of the "Minimum Quantity".

Part Number	Power Rating (W)	Soldering Method	Number of Turns (Effective Rotation Angle)	Total Resistance Value	TCR (ppm/°C)	Remarks
PV22□100A01	1.0(70°C)	Flow/Soldering Iron	22	10 ohm±10%	±100	Non Standard Product (Cd included)
PV22□200A01	1.0(70°C)	Flow/Soldering Iron	22	20 ohm±10%	±100	
PV22□500A01	1.0(70°C)	Flow/Soldering Iron	22	50 ohm±10%	±100	
PV22□101A01	1.0(70°C)	Flow/Soldering Iron	22	100 ohm±10%	±100	
PV22□201A01	1.0(70°C)	Flow/Soldering Iron	22	200 ohm±10%	±100	
PV22□501A01	1.0(70°C)	Flow/Soldering Iron	22	500 ohm±10%	±100	
PV22□102A01	1.0(70°C)	Flow/Soldering Iron	22	1k ohm±10%	±100	
PV22□202A01	1.0(70°C)	Flow/Soldering Iron	22	2k ohm±10%	±100	
PV22□502A01	1.0(70°C)	Flow/Soldering Iron	22	5k ohm±10%	±100	
PV22□103A01	1.0(70°C)	Flow/Soldering Iron	22	10k ohm±10%	±100	
PV22□203A01	1.0(70°C)	Flow/Soldering Iron	22	20k ohm±10%	±100	
PV22□503A01	1.0(70°C)	Flow/Soldering Iron	22	50k ohm±10%	±100	
PV22□104A01	1.0(70°C)	Flow/Soldering Iron	22	100k ohm±10%	±100	
PV22□204A01	1.0(70°C)	Flow/Soldering Iron	22	200k ohm±10%	±100	
PV22□504A01	1.0(70°C)	Flow/Soldering Iron	22	500k ohm±10%	±100	
PV22□105A01	1.0(70°C)	Flow/Soldering Iron	22	1M ohm±10%	±100	
PV22□205A01	1.0(70°C)	Flow/Soldering Iron	22	2M ohm±10%	±100	

■ Construction

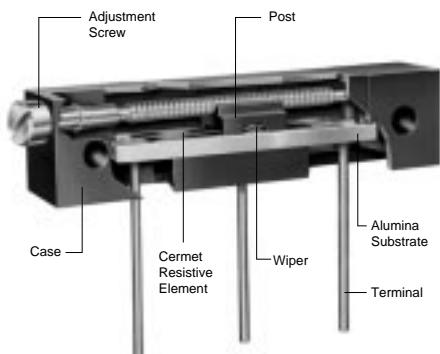

■ Mounting Holes

PV22S

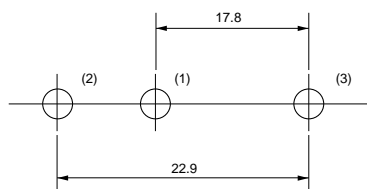

(Tolerance:±0.1 in mm)

PV22Y

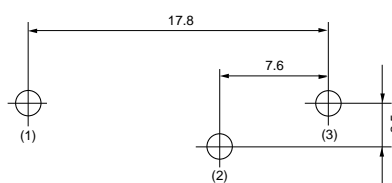

(Tolerance:±0.1 in mm)

Continued on the following page. ↗

↳ Continued from the preceding page.

## ■ Characteristics

Temperature Cycle	$\Delta$ TR	$\pm 2\%$
	$\Delta$ V.S.S.	$\pm 1\%$
Humidity	$\Delta$ TR	$\pm 2\%$
	IR	100Mohm min.
Vibration (20G)	$\Delta$ TR	$\pm 1\%$
	$\Delta$ V.S.S.	$\pm 1\%$
Shock (50G)	$\Delta$ TR	$\pm 1\%$
	$\Delta$ V.S.S.	$\pm 1\%$
Temperature Load Life	$\Delta$ TR	$\pm 3\%$
	$\Delta$ V.S.S.	$\pm 1\%$
Low Temperature Exposure	$\Delta$ TR	$\pm 1\%$
	$\Delta$ V.S.S.	$\pm 1\%$
High Temperature Exposure	$\Delta$ TR	$\pm 2\%$
	$\Delta$ V.S.S.	$\pm 1\%$
Rotational Life (200 cycles)	$\Delta$ TR	$\pm 2\%$

$\Delta$ TR : Total Resistance Change  
 $\Delta$ V.S.S. : Voltage Setting Stability  
 IR : Insulation Resistance

## PV36 Series

### ■ Features

1. High resolution 25-turns enables precision adjustment easily.
2. Sealed construction protects the interior from dust and liquid, which achieves stable performance.
3. Available for ultrasonic cleaning after soldering
4. Clutch mechanism prevents excessive wiper rotation.
5. 5 standard terminal styles
6. Both Top and side adjustment directions.
7. To be complied with RoHS directive by new Cd free cermet resistive material. Pb free terminals with Sn plating.

### ■ Applications

1. Measuring instruments
2. OA equipment
3. Medical equipment
4. Power supply
5. Base station for cellular phone



PV36P

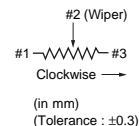
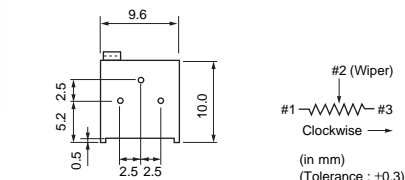
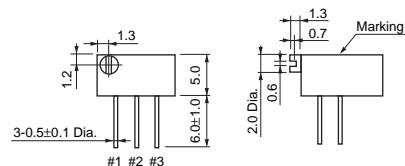

PV36W

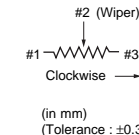
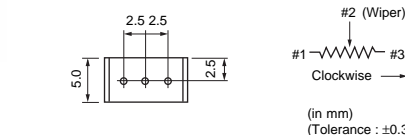
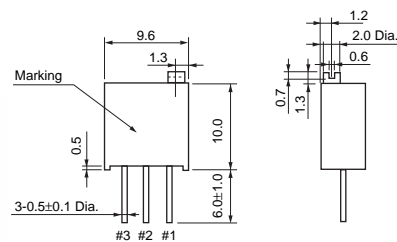

PV36X

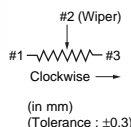
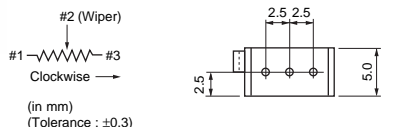
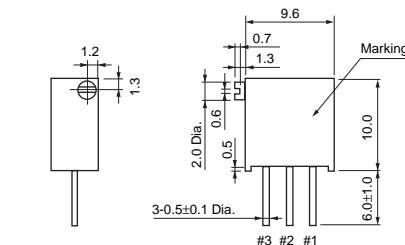

PV36Y

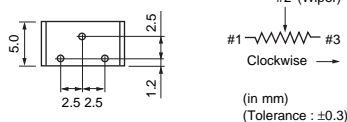
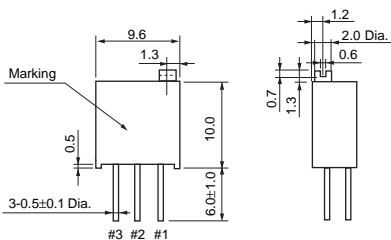

PV36Z

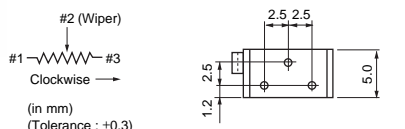
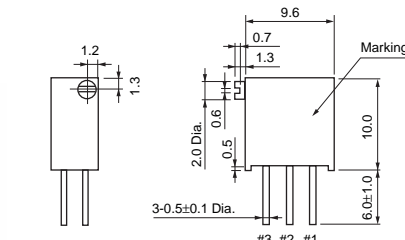

Part Number	Power Rating	Soldering Method	Number of Turns (Effective Rotation Angle)	Total Resistance Value	TCR
PV36□100C01	0.5W(70°C)	Flow/Soldering Iron	25	10ohm ±10%	±150ppm/°C
PV36□200C01	0.5W(70°C)	Flow/Soldering Iron	25	20ohm ±10%	±150ppm/°C
PV36□500C01	0.5W(70°C)	Flow/Soldering Iron	25	50ohm ±10%	±150ppm/°C

Continued on the following page.

Continued from the preceding page.

Part Number	Power Rating	Soldering Method	Number of Turns (Effective Rotation Angle)	Total Resistance Value	TCR
PV36□101C01	0.5W(70°C)	Flow/Soldering Iron	25	100ohm ±10%	±150ppm/°C
PV36□201C01	0.5W(70°C)	Flow/Soldering Iron	25	200ohm ±10%	±100ppm/°C
PV36□501C01	0.5W(70°C)	Flow/Soldering Iron	25	500ohm ±10%	±100ppm/°C
PV36□102C01	0.5W(70°C)	Flow/Soldering Iron	25	1k ohm ±10%	±100ppm/°C
PV36□202C01	0.5W(70°C)	Flow/Soldering Iron	25	2k ohm ±10%	±100ppm/°C
PV36□502C01	0.5W(70°C)	Flow/Soldering Iron	25	5k ohm ±10%	±100ppm/°C
PV36□103C01	0.5W(70°C)	Flow/Soldering Iron	25	10k ohm ±10%	±100ppm/°C
PV36□203C01	0.5W(70°C)	Flow/Soldering Iron	25	20k ohm ±10%	±100ppm/°C
PV36□253C01	0.5W(70°C)	Flow/Soldering Iron	25	25k ohm ±10%	±100ppm/°C
PV36□503C01	0.5W(70°C)	Flow/Soldering Iron	25	50k ohm ±10%	±100ppm/°C
PV36□104C01	0.5W(70°C)	Flow/Soldering Iron	25	100k ohm ±10%	±100ppm/°C
PV36□204C01	0.5W(70°C)	Flow/Soldering Iron	25	200k ohm ±10%	±100ppm/°C
PV36□254C01	0.5W(70°C)	Flow/Soldering Iron	25	250k ohm ±10%	±100ppm/°C
PV36□504C01	0.5W(70°C)	Flow/Soldering Iron	25	500k ohm ±10%	±100ppm/°C
PV36□105C01	0.5W(70°C)	Flow/Soldering Iron	25	1M ohm ±10%	±100ppm/°C
PV36□205C01	0.5W(70°C)	Flow/Soldering Iron	25	2M ohm ±10%	±100ppm/°C
PV36□100C31	0.5W(70°C)	Flow/Soldering Iron	25	10ohm ±10%	±150ppm/°C
PV36□200C31	0.5W(70°C)	Flow/Soldering Iron	25	20ohm ±10%	±150ppm/°C
PV36□500C31	0.5W(70°C)	Flow/Soldering Iron	25	50ohm ±10%	±150ppm/°C
PV36□101C31	0.5W(70°C)	Flow/Soldering Iron	25	100ohm ±10%	±150ppm/°C
PV36□201C31	0.5W(70°C)	Flow/Soldering Iron	25	200ohm ±10%	±100ppm/°C
PV36□501C31	0.5W(70°C)	Flow/Soldering Iron	25	500ohm ±10%	±100ppm/°C
PV36□102C31	0.5W(70°C)	Flow/Soldering Iron	25	1k ohm ±10%	±100ppm/°C
PV36□202C31	0.5W(70°C)	Flow/Soldering Iron	25	2k ohm ±10%	±100ppm/°C
PV36□502C31	0.5W(70°C)	Flow/Soldering Iron	25	5k ohm ±10%	±100ppm/°C
PV36□103C31	0.5W(70°C)	Flow/Soldering Iron	25	10k ohm ±10%	±100ppm/°C
PV36□203C31	0.5W(70°C)	Flow/Soldering Iron	25	20k ohm ±10%	±100ppm/°C
PV36□253C31	0.5W(70°C)	Flow/Soldering Iron	25	25k ohm ±10%	±100ppm/°C
PV36□503C31	0.5W(70°C)	Flow/Soldering Iron	25	50k ohm ±10%	±100ppm/°C
PV36□104C31	0.5W(70°C)	Flow/Soldering Iron	25	100k ohm ±10%	±100ppm/°C
PV36□204C31	0.5W(70°C)	Flow/Soldering Iron	25	200k ohm ±10%	±100ppm/°C
PV36□254C31	0.5W(70°C)	Flow/Soldering Iron	25	250k ohm ±10%	±100ppm/°C
PV36□504C31	0.5W(70°C)	Flow/Soldering Iron	25	500k ohm ±10%	±100ppm/°C
PV36□105C31	0.5W(70°C)	Flow/Soldering Iron	25	1M ohm ±10%	±100ppm/°C
PV36□205C31	0.5W(70°C)	Flow/Soldering Iron	25	2M ohm ±10%	±100ppm/°C

Operating Temperature Range: -55 to 125 °C

The blank column is filled with the code of adjustment direction and lead type (P, X, Y, W and Z).

The order quantity should be an integral multiple of the "Minimum Quantity".

The last three digits express the individual specification codes. C01 for standard type and C31 for radial taping type (PV36W/PV36X series only).

Part Number	Power Rating (W)	Soldering Method	Number of Turns (Effective Rotation Angle)	Total Resistance Value	TCR (ppm/°C)	Remarks
PV36□100A01	0.5(70°C)	Flow/Soldering Iron	25	10 ohm±10%	±100	Non Standard Product (Cd included)
PV36□200A01	0.5(70°C)	Flow/Soldering Iron	25	20 ohm±10%	±100	
PV36□500A01	0.5(70°C)	Flow/Soldering Iron	25	50 ohm±10%	±100	
PV36□101A01	0.5(70°C)	Flow/Soldering Iron	25	100 ohm±10%	±100	
PV36□201A01	0.5(70°C)	Flow/Soldering Iron	25	200 ohm±10%	±100	
PV36□501A01	0.5(70°C)	Flow/Soldering Iron	25	500 ohm±10%	±100	
PV36□102A01	0.5(70°C)	Flow/Soldering Iron	25	1k ohm±10%	±100	
PV36□202A01	0.5(70°C)	Flow/Soldering Iron	25	2k ohm±10%	±100	
PV36□502A01	0.5(70°C)	Flow/Soldering Iron	25	5k ohm±10%	±100	
PV36□103A01	0.5(70°C)	Flow/Soldering Iron	25	10k ohm±10%	±100	
PV36□203A01	0.5(70°C)	Flow/Soldering Iron	25	20k ohm±10%	±100	
PV36□253A01	0.5(70°C)	Flow/Soldering Iron	25	25k ohm±10%	±100	
PV36□503A01	0.5(70°C)	Flow/Soldering Iron	25	50k ohm±10%	±100	
PV36□104A01	0.5(70°C)	Flow/Soldering Iron	25	100k ohm±10%	±100	
PV36□204A01	0.5(70°C)	Flow/Soldering Iron	25	200k ohm±10%	±100	
PV36□254A01	0.5(70°C)	Flow/Soldering Iron	25	250k ohm±10%	±100	
PV36□504A01	0.5(70°C)	Flow/Soldering Iron	25	500k ohm±10%	±100	
PV36□105A01	0.5(70°C)	Flow/Soldering Iron	25	1M ohm±10%	±100	
PV36□205A01	0.5(70°C)	Flow/Soldering Iron	25	2M ohm±10%	±100	
PV36□100A31	0.5(70°C)	Flow/Soldering Iron	25	10 ohm±10%	±100	
PV36□200A31	0.5(70°C)	Flow/Soldering Iron	25	20 ohm±10%	±100	
PV36□500A31	0.5(70°C)	Flow/Soldering Iron	25	50 ohm±10%	±100	
PV36□101A31	0.5(70°C)	Flow/Soldering Iron	25	100 ohm±10%	±100	
PV36□201A31	0.5(70°C)	Flow/Soldering Iron	25	200 ohm±10%	±100	
PV36□501A31	0.5(70°C)	Flow/Soldering Iron	25	500 ohm±10%	±100	
PV36□102A31	0.5(70°C)	Flow/Soldering Iron	25	1k ohm±10%	±100	
PV36□202A31	0.5(70°C)	Flow/Soldering Iron	25	2k ohm±10%	±100	
PV36□502A31	0.5(70°C)	Flow/Soldering Iron	25	5k ohm±10%	±100	
PV36□103A31	0.5(70°C)	Flow/Soldering Iron	25	10k ohm±10%	±100	
PV36□203A31	0.5(70°C)	Flow/Soldering Iron	25	20k ohm±10%	±100	
PV36□253A31	0.5(70°C)	Flow/Soldering Iron	25	25k ohm±10%	±100	
PV36□503A31	0.5(70°C)	Flow/Soldering Iron	25	50k ohm±10%	±100	
PV36□104A31	0.5(70°C)	Flow/Soldering Iron	25	100k ohm±10%	±100	
PV36□204A31	0.5(70°C)	Flow/Soldering Iron	25	200k ohm±10%	±100	
PV36□254A31	0.5(70°C)	Flow/Soldering Iron	25	250k ohm±10%	±100	
PV36□504A31	0.5(70°C)	Flow/Soldering Iron	25	500k ohm±10%	±100	
PV36□105A31	0.5(70°C)	Flow/Soldering Iron	25	1M ohm±10%	±100	
PV36□205A31	0.5(70°C)	Flow/Soldering Iron	25	2M ohm±10%	±100	

■ Construction

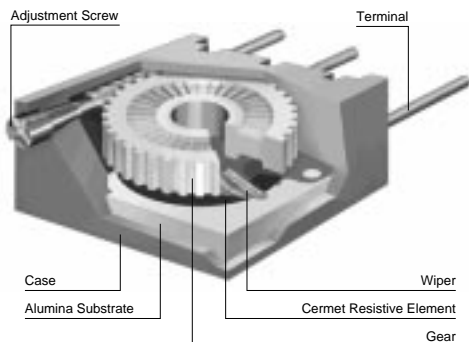

## ■ Mounting Holes

PV36P

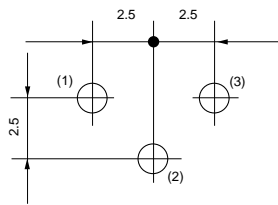

(Tolerance:±0.1  
in mm)

PV36W/X

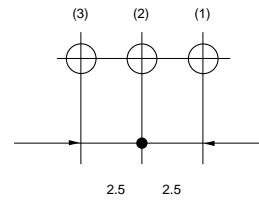

(Tolerance:±0.1  
in mm)

PV36Y/Z

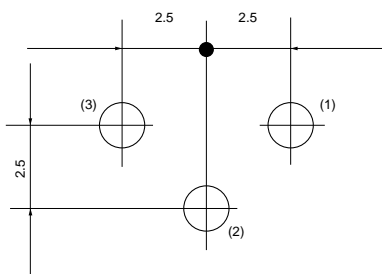

(Tolerance:±0.1  
in mm)

## ■ Characteristics

Temperature Cycle	$\Delta TR$	±2%
	$\Delta V.S.S.$	±1%
Humidity	$\Delta TR$	±2%
	IR	100Mohm min.
Vibration (20G)	$\Delta TR$	±1%
	$\Delta V.S.S.$	±1%
Shock (100G)	$\Delta TR$	±1%
	$\Delta V.S.S.$	±1%
Temperature Load Life	$\Delta TR$	±3%
	$\Delta V.S.S.$	±1%
Low Temperature Exposure	$\Delta TR$	±2%
	$\Delta V.S.S.$	±1%
High Temperature Exposure	$\Delta TR$	±3%
	$\Delta V.S.S.$	±1%
Rotational Life (200 cycles)	$\Delta TR$	$R \leq 1\text{kohm}, R \geq 500\text{kohm} \dots \pm 5\%$ $1\text{kohm} < R < 500\text{kohm} \dots \pm 3\%$

$\Delta TR$  : Total Resistance Change  
 $\Delta V.S.S.$  : Voltage Setting Stability  
 IR : Insulation Resistance  
 R : Standard Total Resistance

## PV12/PV37/PV23/PV22/PV36 Series Notice

### ■ Notice (Operating and Storage Conditions)

1. Store in temperatures of -10 to +40 deg. C and relative humidity of 30-85%RH.
2. Do not store in or near corrosive gases.
3. Use within six months after delivery.
4. Open the package just before using.
5. Do not store under direct sunlight.
6. If you use the trimmer potentiometer in an environment other than listed below, please consult with a Murata factory representative prior to using.  
The trimmer potentiometer should not be used under

- the following environmental conditions:
- (1) Corrosive gaseous atmosphere  
(Ex. Chlorine gas, Hydrogen sulfide gas, Ammonia gas, Sulfuric acid gas, Nitric oxide gas, etc.)
  - (2) In liquid  
(Ex. Oil, Medical liquid, Organic solvent, etc.)
  - (3) Dusty / dirty atmosphere
  - (4) Direct sunlight
  - (5) Static voltage nor electric/magnetic fields
  - (6) Direct sea breeze
  - (7) Other variations of the above

### ■ Notice (Rating)

1. When using with partial load (rheostat), minimize the power depending on the resistance value.
2. The maximum input voltage to a trimmer potentiometer should not exceed  $(P.R)^{1/2}$  or the maximum operating voltage, whichever is smaller.
3. The maximum input current to a trimmer potentiometer should not exceed  $(P/R)^{1/2}$  or the allowable wiper current, whichever is smaller.

### ■ Notice (Soldering and Mounting)

1. Soldering
  - (1) Standard soldering condition
    - (a) Flow soldering :
      - >Pre-heating temp. 80-100 deg. C
      - >Soldering temp. 260 deg. C max.
      - >Soldering time 3 sec. max.
    - (b) Soldering iron :
      - >Temperature of tip 300 deg. C max.
      - >Soldering time 3 sec. max.
      - >Wattage of iron 40W max.

Before using other soldering conditions than those listed above, please consult with Murata factory representative prior to using. If the soldering conditions are not suitable, e.g., excessive time and/or excessive temperature, the trimmer potentiometer may deviate from the specified characteristics.

  - (2) To minimize mechanical stress when adjusting, the trimmer potentiometer should be mounted onto PCB without gap.
  - (3) The soldering iron should not come in contact with the case of the trimmer potentiometer. If such contact does occur, the trimmer potentiometer may be damaged.
2. Mounting
  - (1) Use PCB hole to meet the pin of the trimmer potentiometer. If the trimmer potentiometer installs into insufficient PCB hole, the

- trimmer potentiometer may be damaged by mechanical stress.
- (2) Do not apply excessive force (preferably 9.8N (Ref.: 1kgf) max.), when the trimmer potentiometer is mounted to the PCB.
3. Cleaning
  - (1) Isopropyl-alcohol and Ethyl-alcohol are applicable solvents for cleaning. If you use any other types of solvents, please consult with a Murata factory representative prior to using.
  - (2) The total cleaning time by cold dipping, vapor and ultrasonic washing (conditions as below) method should be less than 3 minutes.
  - (3) For ultra-sonic cleaning, the available condition is as follows.
    - >Power: 600W (67 liter) max.
    - >Frequency: 28kHz
    - >Temperature: Ambient temperature

Due to the ultra-sonic cleaning equipment's peculiar self-resonance point and that the cleaning compatibility usually depends on the jig construction and/or the cleaning condition such as the depth of immersion, please check the cleaning equipment to determine the suitable conditions.

If the trimmer potentiometer is cleaned by other conditions, the trimmer potentiometer may be damaged.



## PV12/PV37/PV23/PV22/PV36 Series Notice

### ■ Notice (Handling)

1. Use suitable screwdrivers that fit comfortably in driver slot. We recommend the screwdrivers below.
  - \* Recommended screwdriver for manual adjustment  
ENGINEER INC. : DA-40  
(Murata P/N : KMDR180)We can supply the screwdrivers above.  
If you place order, please specify the Murata P/N.
2. Don't apply more than 9.8N (Ref.; 1kgf) of twist and stress after mounting onto PCB to prevent contact intermittence. If excessive force is applied, the trimmer potentiometer may not function.
3. When adjusting with an adjustment tool, the applied force to the adjustment screw should not exceed 4.9N (Ref.; 500gf). If excessive force is applied, the trimmer potentiometer may not function due to damage.
4. When using a lock paint to fix slot position, please use adhesive resin without chlorine or sulfur (Three-bond "1401 series").

### ■ Notice (Other)

1. Please make sure that your product has been evaluated and confirmed against your specifications when our product is mounted to your product.
2. Murata cannot guarantee trimmer potentiometer integrity when used under conditions other than those specified in this document.

# Trimmer Potentiometers



## Angle Sensing Potentiometer SMD Dust-proof Type 12mm Size PVS1 Series

### ■ Features

1. Dust-proof construction protects the interior from dust, which maintains stable characteristics.
2. Compliant to high peak temperature lead free soldering.
3. Excellent resistance materials and high reliability wiper achieves 1M cycles.
4. D formation thru-hole rotor enables selection of any kind of gear shape.
5. Leaded terminal type is available.
6. Ultra-thin size (2.1mm height)
7. Au plated terminals without Lead.

### ■ Applications

1. Animal robot
2. Switch for automotive
3. Motor drive unit
4. Radio control equipment
5. Electric motor-driven bicycle



PVS1A

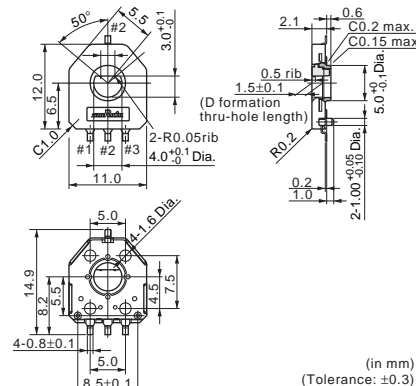

PVS1L

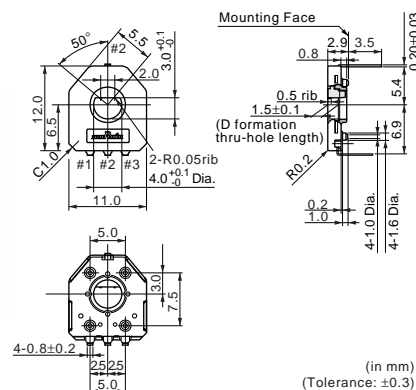

Part Number	Total Resistance Value (k ohm)	Linearity (%)	Effective Rotational Angle	TCR	Rotational Life
<b>PVS1A103A01 (SV01A103AEA01)</b>	10 ±30%	±2	333.3° (Ref.)	±500ppm/°C	1M cycles
<b>PVS1L103A03 (SV01L103AEA11)</b>	10 ±30%	±2	333.3° (Ref.)	±500ppm/°C	1M cycles

PVS1 series will be changed to new part number "SV01" since Oct. 1, 2004.

### ■ Construction

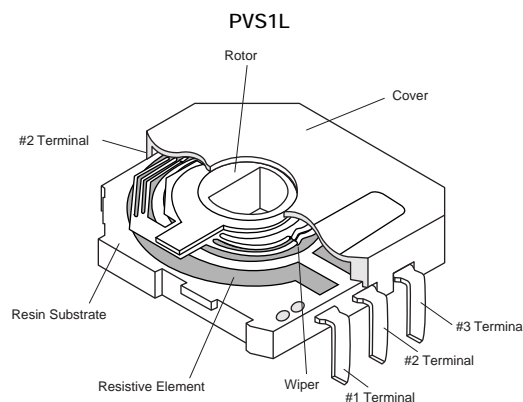
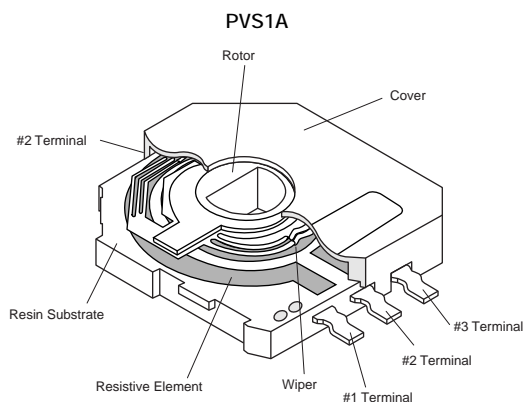

Continued on the following page. ↗

Continued from the preceding page.

### Standard Land Pattern

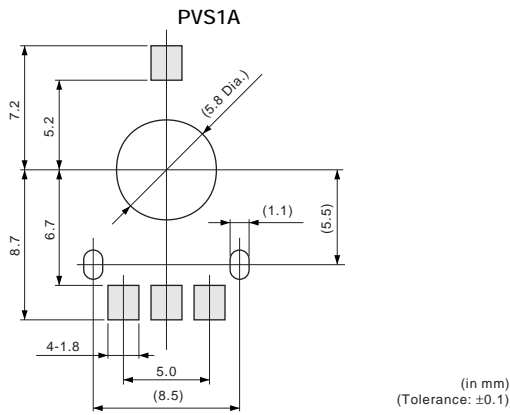

### Standard Mounting Holes

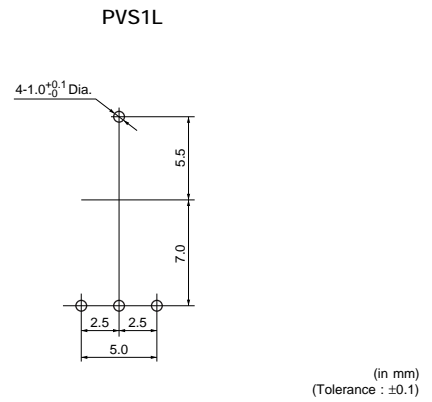

### Characteristics

Temperature Cycle (Thermal Shock)	$\Delta$ TR	±20%
	Linearity	±3%
Humidity	$\Delta$ TR	±20%
	Linearity	±3%
Vibration	$\Delta$ TR	±10%
	Linearity	±3%
Shock (20G)	$\Delta$ TR	±10%
	Linearity	±3%
Humidity Load Life	$\Delta$ TR	±20%
	Linearity	±3%
High Temperature Exposure	$\Delta$ TR	+5/-30%
	Linearity	±3%
Low Temperature Exposure	$\Delta$ TR	±20%
	Linearity	±3%
Rotational Life (1M cycles)	$\Delta$ TR	±20%
	Linearity	±3%

$\Delta$ TR: Total Resistance Change

## PVS1 Series Notice

### ■ Notice (Operating and Storage Conditions)

1. Store in temperatures of -10 to +40deg. C and relative humidity of 30-85%RH.
2. Do not store in or near corrosive gases.
3. Use within six months after delivery.
4. Open the package just before using.
5. Do not store under direct sunlight.
6. Do not use the rotary position sensor under the following environmental conditions. If you use the rotary position sensor in an environment other than these listed below, please consult with Murata factory representative prior to using.

- (1) Corrosive gasses atmosphere  
(Ex. Chlorine gas, Hydrogen sulfide gas, Ammonia gas, Sulfuric acid gas, Nitric oxide gas, etc.)
- (2) In liquid  
(Ex. Water, Oil, Medical liquid, Organic solvent, etc.)
- (3) Dusty / dirty atmosphere
- (4) Direct sunlight
- (5) Static voltage nor electric/magnetic fields
- (6) Direct sea breeze
- (7) Other variations of the above

### ■ Notice (Soldering and Mounting)-PVS1A Type

1. Soldering
    - (1) PVS1A series can be soldered by reflow soldering method and soldering iron. Do not use flow soldering method (dipping).
    - (2) The dimension of land pattern used should be Murata's standard land pattern at reflow soldering. Excessive land area may cause displacement due to the effect of the surface tension of the solder. Insufficient land area may cause insufficient soldering strength on PCB.
    - (3) Standard soldering condition
      - (a) Reflow soldering : Refer to the standard temperature profile.
      - (b) Soldering iron:
        - >Temperature of tip 360 deg. C max.
        - >Soldering time 3 sec. max./1 terminal
        - >Diameter 3mm max.
        - >Wattage of iron 30W max.
- Before using other soldering conditions than those listed above, please consult with Murata factory representative prior to using. If the

- soldering conditions are not suitable, e.g., excessive time and/or excessive temperature, the rotary position sensor may deviate from the specified characteristics.
- (4) The amount of solder is critical. Insufficient amounts of solder can lead to insufficient soldering strength on PCB. Excessive amounts of solder may cause bridging between the terminals.
  - (5) The soldering iron should not come in contact with the cover of the rotary position sensor. If such contact does occur, the rotary position sensor may be damaged.

#### 2. Mounting

- (1) Do not apply excessive force (preferable 9.8N (Ref.; 1kgf) max.), when the rotary position sensor is mounted to the PCB.
- (2) Do not warp and/or bend PCB to prevent the rotary position sensor from breakage.

#### 3. Cleaning

Cannot be cleaned because of open construction.

### ■ Notice (Soldering and Mounting)-PVS1L Type

1. Soldering
    - (1) PVS1L series can be soldered by flow soldering method and soldering iron. Do not use reflow soldering method.
    - (2) Standard soldering condition
      - (a) Flow soldering
        - >Pre-heating temp.: 80-100 deg. C
        - >Soldering temp. : 260 deg. C max.
        - >Soldering time : 3 sec. max.
      - (b) Soldering iron
        - >Temperature of tip: 360 deg. C max.
        - >Soldering time : 3 sec. max./1 terminal
        - >Diameter : 3mm max.
        - >Wattage of iron : 30W max.
- Before using other soldering conditions than those listed above, please consult with Murata factory representative prior to using. If the

- soldering conditions are not suitable, e.g., excessive time and/or excessive temperature, the rotary position sensor may deviate from the specified characteristics.
- (3) The amount of solder is critical.
  - (4) The soldering iron should not come in contact with the cover of the rotary position sensor. If such contact does occur, the rotary position sensor may be damaged.

#### 2. Mounting

- (1) Use PCB hole to meet the pin of the rotary position sensor. If the rotary position sensor is installed into insufficient PCB hole, the rotary position sensor may be damaged by mechanical stress.
- (2) Do not apply excessive force (preferably 9.8N (Ref.; 1kgf) max.), when the rotary position

Continued on the following page. 

## PVS1 Series Notice

☒ Continued from the preceding page.

sensor is mounted to the PCB.

Cannot be cleaned because of open construction.

### 3. Cleaning

#### ■ Reflow Soldering Standard Profile

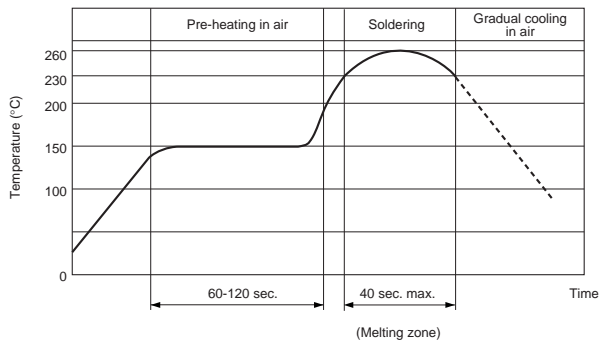

#### ■ Notice (Handling)

Uncontrolled mechanical force except usual rotation on the hollow rotor of product, may cause big change of electrical characteristic, big increase of rotational torque or mechanical damage of product.

Therefore, please pay your attention on the following points for your design.

1. The fixing method of product must be soldering by the terminals of product. And please don't fix by screw cramping of supporting board which might cause mechanical deformation of product.
2. Your connecting shaft must be sustained by your bearing and any uncontrolled force should not apply on the hollow rotor of product.

#### ■ Notice (Other)

1. Please make sure the connecting impedance is not to be less than 10M ohm. The rotary position sensor is designed to connect the output terminal and A/D port of the microprocessor directly. Therefore, connecting impedance presupposes certain M ohm and the contact resistance is set high.
2. To minimize the processing error and noise influence which occur in rare cases, when data is installed through the product, please note the following items and program your software.
  - (1) Data install should be done plural times and applied the mean value.
  - (2) Data considered as error should be invalid.
  - (3) If suspicious data is found, the data should be re-installed.
3. Before using rotary position sensor, please test after assembly in your particular mass production system.
4. MURATA cannot guarantee rotary position sensor integrity when used under conditions other than those specified in this document.

## SMD Open Type and SMD Sealed Type PVM4A\_C01 Series Specifications and Test Methods

The tests and measurements should be conducted under the condition of 15 to 35°C of temperature, 25 to 75% of relative humidity and 86 to 106 kpa of atmospheric pressure unless otherwise specified. If questionable results occur that have been measured in accordance with the above mentioned conditions, the tests and measurements should be conducted under the condition of 25±2°C of temperature and, 45 to 55% of relative humidity and 86 to 106 kpa of atmospheric pressure.

No.	Item	Test Methods																														
1	Total Resistance	<p>Measure total resistance between the resistance element and terminals (terminals #1 and #3) with the contact arm positioned against a stop. The positioning of the contact arm and terminal should be the same for subsequent total resistance measurements on the same device.</p> <p>Use the test voltage specified in Table-1 for total resistance measurements. This voltage should be used whenever a subsequent total resistance measurement is made.</p> <table border="1"> <thead> <tr> <th>Total Resistance, Nominal (ohm)</th> <th>Maximum Test Voltage (V)</th> </tr> </thead> <tbody> <tr> <td>10≤R≤100</td> <td>1.0</td> </tr> <tr> <td>100&lt;R≤1k</td> <td>3.0</td> </tr> <tr> <td>1k&lt;R≤10k</td> <td>10.0</td> </tr> <tr> <td>10k&lt;R≤100k</td> <td>30.0</td> </tr> <tr> <td>100k&lt;R</td> <td>100.0</td> </tr> </tbody> </table> <p>Table 1: Total resistance test voltage</p>	Total Resistance, Nominal (ohm)	Maximum Test Voltage (V)	10≤R≤100	1.0	100<R≤1k	3.0	1k<R≤10k	10.0	10k<R≤100k	30.0	100k<R	100.0																		
Total Resistance, Nominal (ohm)	Maximum Test Voltage (V)																															
10≤R≤100	1.0																															
100<R≤1k	3.0																															
1k<R≤10k	10.0																															
10k<R≤100k	30.0																															
100k<R	100.0																															
2	Residual Resistance	<p>Position the contact arm at the extreme counterclockwise limit of mechanical travel and measure the resistance between the contact arm and the corresponding end terminal. Then, position the contact arm at the extreme clockwise limit of mechanical travel and measure the resistance between the contact arm and the corresponding end terminal. During this test, take suitable precautions to ensure that the rated current of the resistance element is not exceeded.</p>																														
3	Contact Resistance	<p>Contact resistance variation should be measured with the measuring circuit shown below, or its equivalent. The operating wiper should be rotated in both directions through 90% of the actual effective-electrical travel for a total of 6 cycles.</p> <p>The rate of rotation of the operating wiper should be such that the wiper completes 1 count in determining whether or not a contact resistance variation is observed at least twice in the same location. The test current should follow the value given in Table-2 unless otherwise limited by the power rating.</p> <table border="1"> <thead> <tr> <th>Standard Total Resistance R (ohm)</th> <th>Test Current</th> </tr> </thead> <tbody> <tr> <td>100≤R&lt;10k</td> <td>10mA max.</td> </tr> <tr> <td>10k≤R&lt;100k</td> <td>1mA max.</td> </tr> <tr> <td>100k≤R</td> <td>100μA max.</td> </tr> </tbody> </table> <p>Table 2: Test current for CRV</p> <p>Figure 1: CRV measuring circuit</p>	Standard Total Resistance R (ohm)	Test Current	100≤R<10k	10mA max.	10k≤R<100k	1mA max.	100k≤R	100μA max.																						
Standard Total Resistance R (ohm)	Test Current																															
100≤R<10k	10mA max.																															
10k≤R<100k	1mA max.																															
100k≤R	100μA max.																															
4	Humidity Exposure	<p>The wiper contact point should be preset at about 50% position of effective rotational angle. After that, the potentiometer should be placed in a chamber at 40±2°C and 90 - 95% without loading for 500±12 hours.</p> <p>The resistance value should be measured after keeping the potentiometer in a room for 5±1/6 hours.</p>																														
5	High Temperature Exposure	<p>The wiper contact point should be preset at about 50% position of effective rotational angle. After that, the potentiometer should be placed in a chamber at 70±2°C without loading for 500±12 hours. The resistance value should be measured after keeping the potentiometer in a room for 1.5±1/6 hours.</p>																														
6	Humidity Load Life	<p>The wiper contact point should be preset at about 50% position of effective rotational angle. After that, the potentiometer should be placed in a chamber at 40±2°C and 90 - 95% with loading the 1/2 rated voltage between #1 and #2 terminals, intermittently 1.5 hours ON and 0.5 hours OFF for 1000±12 hours.</p> <p>The resistance value should be measured after keeping the potentiometer in a room for 5±1/6 hours.</p>																														
7	Load Life	<p>The wiper contact point should be preset at about 50% position of effective rotational angle. After that, the potentiometer should be placed in a chamber at 70±2°C (50±2°C for PVZ) with loading the 1/2 rated voltage between #1 and #2 terminals, intermittently 1.5 hours ON and 0.5 hours OFF for 1000±12 hours. The resistance value should be measured after keeping the potentiometer in a room for 1.5±1/6 hours.</p>																														
8	Temperature Cycle	<p>The wiper contact point should be preset at about 50% position of effective rotational angle. After that, the potentiometer should be subjected to Table 3, Table 4 temperature for 5 cycles. The resistance value should be measured after keeping the potentiometer in a room for 1.5±10 minutes.</p> <table border="1"> <thead> <tr> <th>Sequence</th> <th>1</th> <th>2</th> <th>3</th> <th>4</th> </tr> </thead> <tbody> <tr> <td>Temp. (°C)</td> <td>-25±3</td> <td>+25±2</td> <td>+85±3</td> <td>+25±2</td> </tr> <tr> <td>Time (min.)</td> <td>30±3</td> <td>10max.</td> <td>30±3</td> <td>10max.</td> </tr> </tbody> </table> <p>Table 3: PVZ</p> <table border="1"> <thead> <tr> <th>Sequence</th> <th>1</th> <th>2</th> <th>3</th> <th>4</th> </tr> </thead> <tbody> <tr> <td>Temp. (°C)</td> <td>-55±3</td> <td>+25±2</td> <td>+125±3</td> <td>+25±2</td> </tr> <tr> <td>Time (min.)</td> <td>30±3</td> <td>10max.</td> <td>30±3</td> <td>10max.</td> </tr> </tbody> </table> <p>Table 4: PVA3/PVS3/PVM4A□□□C01</p>	Sequence	1	2	3	4	Temp. (°C)	-25±3	+25±2	+85±3	+25±2	Time (min.)	30±3	10max.	30±3	10max.	Sequence	1	2	3	4	Temp. (°C)	-55±3	+25±2	+125±3	+25±2	Time (min.)	30±3	10max.	30±3	10max.
Sequence	1	2	3	4																												
Temp. (°C)	-25±3	+25±2	+85±3	+25±2																												
Time (min.)	30±3	10max.	30±3	10max.																												
Sequence	1	2	3	4																												
Temp. (°C)	-55±3	+25±2	+125±3	+25±2																												
Time (min.)	30±3	10max.	30±3	10max.																												

Continued on the following page.

## SMD Open Type and SMD Sealed Type PVM4A\_C01 Series Specifications and Test Methods

Continued from the preceding page.

No.	Item	Test Methods																				
9	Temperature Coefficient of Resistance	<p>The trimmer potentiometer should be subjected to each of the following temperatures (see Table 5, Table 6) for 30 to 45 minutes. The resistance value should be measured in the chamber.</p> $TCR = \frac{R_2 - R_1}{R_1 (T_2 - T_1)} \times 10^6 \text{ (ppm/}^\circ\text{C)}$ <p>                     T<sub>1</sub> : Reference temperature in degrees celsius                      T<sub>2</sub> : Test temperature in degrees celsius                      R<sub>1</sub> : Resistance at reference temperature in ohm                      R<sub>2</sub> : Resistance at test temperature in ohm                 </p> <table border="1" style="display: inline-table; margin-right: 20px;"> <thead> <tr> <th>Sequence</th> <th>1*</th> <th>2</th> <th>3*</th> <th>4</th> </tr> </thead> <tbody> <tr> <td>Temp. (°C)</td> <td>+25±2</td> <td>-25±3</td> <td>+25±2</td> <td>+85±3</td> </tr> </tbody> </table> <p>Note*: Norm temp.</p> <p style="text-align: center;">Table 5: PVZ</p> <table border="1" style="display: inline-table;"> <thead> <tr> <th>Sequence</th> <th>1</th> <th>2</th> <th>3*</th> <th>4</th> </tr> </thead> <tbody> <tr> <td>Temp. (°C)</td> <td>+25±2</td> <td>-55±3</td> <td>+25±2</td> <td>+125±3</td> </tr> </tbody> </table> <p style="text-align: center;">Table 6: PVA3/PVS3/PVM4A□□□C01</p>	Sequence	1*	2	3*	4	Temp. (°C)	+25±2	-25±3	+25±2	+85±3	Sequence	1	2	3*	4	Temp. (°C)	+25±2	-55±3	+25±2	+125±3
Sequence	1*	2	3*	4																		
Temp. (°C)	+25±2	-25±3	+25±2	+85±3																		
Sequence	1	2	3*	4																		
Temp. (°C)	+25±2	-55±3	+25±2	+125±3																		
10	Rotational Life	<p>The wiper should be rotated over 90% of the effective rotational angle without loading at a speed of 10 cycles per minute, for 10 cycles continuously. The resistance value should be measured after keeping the potentiometer in a room for 10±5 minutes.</p>																				

## SMD Sealed Type/Lead Sealed Type Specifications and Test Methods

The following describes trimmer potentiometer testing conducted by Murata Manufacturing Co., Ltd. in accordance with MIL-R-22097 (Military specification for variable resistors, non-wirewound) and MIL-STD-202 (Test methods for electronic and electrical component parts).

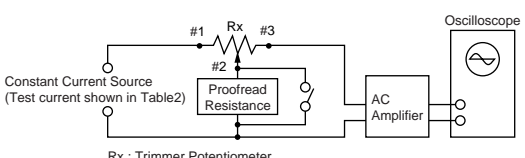
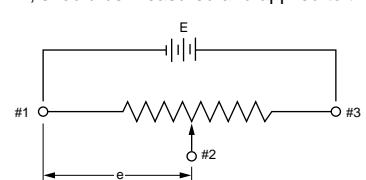
No.	Item	Test Methods																				
1	Total Resistance	<p>Measure total resistance between the resistance element and terminals (#1 and #3) with the contact arm positioned against a stop. The positioning of the contact arm and terminal should be the same for subsequent total resistance measurements on the same device. Use the test voltage specified in Table 1 for total resistance measurements. This voltage should be used for all subsequent total resistance measurements.</p> <table border="1" style="margin-left: auto; margin-right: auto; border-collapse: collapse;"> <thead> <tr style="background-color: #f2f2f2;"> <th>Total Resistance, Nominal (ohm)</th> <th>Maximum Test Voltage (V)</th> </tr> </thead> <tbody> <tr> <td>10 ≤ R ≤ 100</td> <td>1.0</td> </tr> <tr> <td>100 &lt; R ≤ 1k</td> <td>3.0</td> </tr> <tr> <td>1k &lt; R ≤ 10k</td> <td>10.0</td> </tr> <tr> <td>10k &lt; R ≤ 100k</td> <td>30.0</td> </tr> <tr> <td>100k &lt; R</td> <td>100.0</td> </tr> </tbody> </table> <p style="text-align: center;">Table 1: Total resistance test voltage</p>	Total Resistance, Nominal (ohm)	Maximum Test Voltage (V)	10 ≤ R ≤ 100	1.0	100 < R ≤ 1k	3.0	1k < R ≤ 10k	10.0	10k < R ≤ 100k	30.0	100k < R	100.0								
Total Resistance, Nominal (ohm)	Maximum Test Voltage (V)																					
10 ≤ R ≤ 100	1.0																					
100 < R ≤ 1k	3.0																					
1k < R ≤ 10k	10.0																					
10k < R ≤ 100k	30.0																					
100k < R	100.0																					
2	Residual Resistance	<p>Position the contact arm at the extreme counterclockwise limit of mechanical travel and measure the resistance between the contact arm and the corresponding end terminal. Then, position the contact arm at the extreme clockwise limit of mechanical travel and measure the resistance between the contact arm and the corresponding end terminal. During this test, take suitable precautions to ensure that the rated current of the resistance element is not exceeded.</p>																				
3	Contact Resistance Variation	<p>Contact resistance variation should be measured with the measuring circuit shown in Figure 1, or its equivalent. The adjustment rotor (screw) should be rotated in both directions through 90% of the actual effective-electrical rotational angle (number of turns) for a total of 6 cycles. Only the last 3 cycles should count in determining whether or not a contact resistance variation is observed at least twice in the same location, exclusive of the roll-on or roll-off points where the contact arm moves from the termination, on or off, the resistance element. The rate of rotation of the adjustment rotor (screw) should be such that the adjustment rotor (screw) completes 1 cycle for 5 seconds minimum to 2 minutes maximum. The test current used should follow the value given in Table 2 unless otherwise limited by power rating.</p> <table border="1" style="margin-left: auto; margin-right: auto; border-collapse: collapse;"> <thead> <tr style="background-color: #f2f2f2;"> <th>Standard Total Resistance R (ohm)</th> <th>Test Current</th> </tr> </thead> <tbody> <tr> <td>R ≤ 100</td> <td>20mA</td> </tr> <tr> <td>100 &lt; R &lt; 500</td> <td>10mA</td> </tr> <tr> <td>500 ≤ R &lt; 1k</td> <td>4mA</td> </tr> <tr> <td>1k ≤ R &lt; 2k</td> <td>2mA</td> </tr> <tr> <td>2k ≤ R &lt; 50k</td> <td>1mA</td> </tr> <tr> <td>50k ≤ R &lt; 200k</td> <td>200µA</td> </tr> <tr> <td>200k ≤ R &lt; 1M</td> <td>100µA</td> </tr> <tr> <td>1M ≤ R &lt; 2M</td> <td>50µA</td> </tr> <tr> <td>2M ≤ R</td> <td>30µA</td> </tr> </tbody> </table> <p style="text-align: center;">Table 2: Test current for CRV</p> <div style="text-align: right; margin-top: 10px;">  <p style="font-size: small;">Rx : Trimmer Potentiometer Oscilloscope bandwidth : 100Hz to 50kHz</p> <p style="text-align: center;">Figure 1: CRV measuring circuit</p> </div>	Standard Total Resistance R (ohm)	Test Current	R ≤ 100	20mA	100 < R < 500	10mA	500 ≤ R < 1k	4mA	1k ≤ R < 2k	2mA	2k ≤ R < 50k	1mA	50k ≤ R < 200k	200µA	200k ≤ R < 1M	100µA	1M ≤ R < 2M	50µA	2M ≤ R	30µA
Standard Total Resistance R (ohm)	Test Current																					
R ≤ 100	20mA																					
100 < R < 500	10mA																					
500 ≤ R < 1k	4mA																					
1k ≤ R < 2k	2mA																					
2k ≤ R < 50k	1mA																					
50k ≤ R < 200k	200µA																					
200k ≤ R < 1M	100µA																					
1M ≤ R < 2M	50µA																					
2M ≤ R	30µA																					
4	Temperature Coefficient of Resistance	<p>The trimmer potentiometer should be subjected to each of the following temperatures (see Table 3) for 30-45 minutes. Temperature coefficient of resistance should be applied to the following formula.</p> $TCR = \frac{R_2 - R_1}{R_1 (T_2 - T_1)} \times 10^6 \text{ (ppm/°C)}$ <p style="margin-left: 20px;"> <math>T_1</math> : Reference temperature in degrees celsius  <math>T_2</math> : Test temperature in degrees celsius  <math>R_1</math> : Resistance at reference temperature ohm  <math>R_2</math> : Resistance at test temperature in ohm         </p> <table border="1" style="margin-left: auto; margin-right: auto; border-collapse: collapse; text-align: center;"> <thead> <tr style="background-color: #f2f2f2;"> <th>Sequence</th> <th>1*</th> <th>2</th> <th>3</th> <th>4*</th> <th>5</th> <th>6</th> </tr> </thead> <tbody> <tr> <td>Temperature (°C)</td> <td>+25</td> <td>-15</td> <td>Min. operating Temperature</td> <td>+25</td> <td>+65</td> <td>Max. operating Temperature</td> </tr> </tbody> </table> <p style="font-size: x-small;">Note*: Reference temperature</p> <p style="text-align: center;">Table 3: Test temperatures</p>	Sequence	1*	2	3	4*	5	6	Temperature (°C)	+25	-15	Min. operating Temperature	+25	+65	Max. operating Temperature						
Sequence	1*	2	3	4*	5	6																
Temperature (°C)	+25	-15	Min. operating Temperature	+25	+65	Max. operating Temperature																
5	Voltage Setting Stability	<p>The wiper should be set at approximately 40% of the actual effective-electrical rotational angle (number of turns). An adequate DC test potential should be applied between terminal #1 and terminal #3. The voltage between terminal #1 and terminal #3, and the voltage between terminal #1 and terminal #2, should be measured and applied to the following formula.</p> $\text{Voltage setting stability} = \left( \frac{e'}{E} - \frac{e}{E} \right) \times 100 \text{ (\%)}$ <p style="margin-left: 20px;"> <math>e</math> : Before test              (The voltage between terminal #1 and terminal #2)  <math>e'</math> : After test              (The voltage between terminal #1 and terminal #2)  <math>E</math> : The voltage between terminal #1 and terminal #3         </p> <div style="text-align: right; margin-top: 10px;">  <p style="text-align: center;">Figure 2</p> </div>																				

Continued on the following page.



## SMD Sealed Type/Lead Sealed Type Specifications and Test Methods

Continued from the preceding page.

No.	Item	Test Methods																				
6	Temperature Cycle	<p>The trimmer potentiometer should be subjected to Table 4 temperature for 5 cycles. The trimmer potentiometer should be removed from the chamber, and maintained at a temperature of 25±5°C for 1–2 hours.</p> <table border="1"> <thead> <tr> <th>Sequence</th> <th>1</th> <th>2</th> <th>3</th> <th>4</th> </tr> </thead> <tbody> <tr> <td>Temp. (°C)</td> <td>PV□□ series -55±3</td> <td>+25±2</td> <td>+125±3 +150±3</td> <td>+25±2</td> </tr> <tr> <td></td> <td>PV22 series -25±3</td> <td></td> <td>+60±3</td> <td></td> </tr> <tr> <td>Time (min.)</td> <td>30</td> <td>5 max.</td> <td>30</td> <td>5 max.</td> </tr> </tbody> </table> <p>Table 4: One cycle of temperature cycle.</p>	Sequence	1	2	3	4	Temp. (°C)	PV□□ series -55±3	+25±2	+125±3 +150±3	+25±2		PV22 series -25±3		+60±3		Time (min.)	30	5 max.	30	5 max.
Sequence	1	2	3	4																		
Temp. (°C)	PV□□ series -55±3	+25±2	+125±3 +150±3	+25±2																		
	PV22 series -25±3		+60±3																			
Time (min.)	30	5 max.	30	5 max.																		
7	Humidity	<p>1) PVC6, PV12, PV32, PV34 PVM4A□□□D01 series The trimmer potentiometer should be placed in a chamber at a temperature of 40±2°C and a humidity of 90–95% without loading for 250±8 hours (500±12 hours for PVM4A□□□D01 series). The trimmer potentiometer should be removed from the chamber, and maintained at a temperature of 25±5°C for 5±1/6 hours.</p> <p>2) PVF2 series The trimmer potentiometer should be placed in a chamber at 60±2°C and 90–95% without loading for 1000±12 hours. The trimmer potentiometer should be removed from the chamber, and maintained at a temperature of 25±5°C for 5±1/6 hours</p> <p>2) PVG3, PVG5, PV01, PV22, PV23, PV36, PV37 series The trimmer potentiometer should be subjected Figure-3 the programmed humidity environment for 10 cycle. The trimmer potentiometer should be removed from the chamber, and maintained at a temperature of 25±5°C for 1.5±1/2 hours.</p> <p>Figure 3</p>																				
8	Vibration	<p>1) PV□□ series The trimmer potentiometer should be vibrated throughout the frequency range at the 20G level. A complete frequency range, 10Hz to 2000Hz and back, should be made within 15 minutes for a total of 4 sweeps in each of the three axis direction for a total of 12 sweeps.</p> <p>2) PVF2 series The trimmer potentiometer should be subjected to vibration at 0.3 inch amplitude. The frequency should be varied uniformly between the approximate limits of 10Hz and 55Hz. This motion should be applied for period of 2 hours in each of 3 mutually perpendicular directions (total of 6 hours).</p>																				
9	Shock	<p>1) PV□□ series The trimmer potentiometer should be shocked at the 100G (50G for PV22 and PV23 series) level and should be subjected to 4 shocks in each of the three axis directions for a total of 12 shocks.</p> <p>2) PVM4A□□□D01 series The trimmer potentiometer should be shocked at the 100G level and should be subjected to 3 shocks in each of the six axis directions for a total of 18 shocks.</p>																				
10	Temperature Road Life	<p>Full rated continuous working voltage not exceeding the maximum rated voltage should be applied intermittently between terminal #1 and terminal #3 of the trimmer potentiometer, 1.5 hours on and 0.5 hours off, for a total of 1000±12 hours, at a temperature of 70±2°C (85±2°C for PV01 and PV37 series, 50±2°C for PVF2 series). The trimmer potentiometer should be removed from the chamber, and maintained at a temperature of 25±5°C for 1 to 2 hours.</p>																				
11	High Temperature Exposure (Except for PVF2)	<p>The trimmer potentiometer should be placed in a chamber at a temperature of 125±3°C (150±3°C for PV22 series) 250±8 hours without loading. The trimmer potentiometer should be removed from the chamber, and maintained at a temperature of 25±5°C for 1 to 2 hours.</p>																				
12	Low Temperature Exposure (Except for PVF2 and PVM4A□□□D01)	<p>The trimmer potentiometer should be placed in a chamber at a temperature of -55±3°C for 1 hours without loading. Full rated continuous working voltage not exceeding the maximum rated voltage should be applied for 45 minutes. The trimmer potentiometer should be removed from the chamber, and maintained at a temperature of 25±5°C for approximately 24 hours.</p>																				

Continued on the following page. ↗

## SMD Sealed Type/Lead Sealed Type Specifications and Test Methods

☐ Continued from the preceding page.

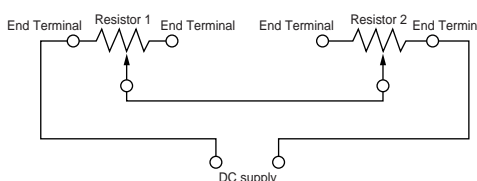
No.	Item	Test Methods
13	Low Temperature Operation (Only for PVF2 and PVM4A□□□D01)	The trimmer potentiometer should be placed in a chamber at a temperature of $-25\pm 3^{\circ}\text{C}$ ( $-55\pm 3^{\circ}\text{C}$ for PVM4A□□□D01 series) $48\pm 4$ hours without loading. The trimmer potentiometer should be removed from the chamber, and maintained at a temperature of $25\pm 5^{\circ}\text{C}$ for 1-2 hours
14	Rotational Life	<p>1) PV□□ series Full rated continuous working voltage not exceeding the maximum rated voltage should be applied with the circuit shown in the figure. The adjustment rotor (screw) should be continuously cycled through not less than 90% of effective-electrical rotational angle (number of turns), at the rate of 1 cycle for 5 seconds minimum to 2.5 minutes maximum for total of 200 cycles.</p> <div style="text-align: center;">  <p>Figure 4</p> </div> <p>2) PVG3, PVG5 series The adjustment rotor (screw) should be continuously cycled though not less than 90% of effective-electrical rotational angle (number of turns), at the rate of 1 cycle for 5 seconds minimum to 2.5 minutes maximum for a total of 50 (100 for PVG5) cycles, without loading.</p> <p>3) PVF2, PVM4A□□□D01 series The wiper should be rotated over 90% of the effective rotational angle without loading at a speed of 10 cycles per minute, for 100 cycles continuously.</p>

# Angle Sensing Potentiometer Specifications and Test Methods

No.	Item	Test Methods															
1	Linearity	<p>Independent linearity should vary no more than ±2% within ±160° to 50% voltage ratio. Taper : linear, 100%/333.3° Measured with the circuit as below (Figure 1).</p> <p>Output voltage ratio (%)</p> $\left( \frac{V(1-2)}{V(1-3)} \times 100 \right)$ <p>Rotational angle (°)</p> <p>Figure-1</p>															
2	Temperature Coefficient of Resistance	<p>The rotary position sensor should be subjected to each of the following temperatures (see Table 1) for 30-45 minutes. Temperature coefficient of resistance should be applied to the following formula.</p> $TCR = \frac{R_2 - R_1}{R_1 (t_2 - t_1)} \times 10^6 \text{ (ppm/°C)}$ <p>t<sub>1</sub> : Reference temperature in degrees celsius t<sub>2</sub> : Test temperature in degrees celsius R<sub>1</sub> : Resistance at reference temperature in ohm R<sub>2</sub> : Resistance at test temperature in ohm</p> <table border="1"> <thead> <tr> <th>Sequence</th> <th>*1</th> <th>2</th> <th>*3</th> <th>4</th> </tr> </thead> <tbody> <tr> <td>Temperature (°C)</td> <td>+25</td> <td>-40</td> <td>+25</td> <td>+85</td> </tr> </tbody> </table> <p>Note * : Reference temperature</p> <p>Table-1 Test temperatures</p>	Sequence	*1	2	*3	4	Temperature (°C)	+25	-40	+25	+85					
Sequence	*1	2	*3	4													
Temperature (°C)	+25	-40	+25	+85													
3	Temperature Cycle (Thermal Shock)	<p>The rotary position sensor should be subjected to Table 2 temperature for 5 cycles. Then, the rotary position sensor should be kept in the dry box for 24 +8/-0 hrs.</p> <table border="1"> <thead> <tr> <th>Sequence</th> <th>1</th> <th>2</th> <th>3</th> <th>4</th> </tr> </thead> <tbody> <tr> <td>Temperature (°C)</td> <td>-40±3</td> <td>+25±2</td> <td>+85±3</td> <td>+25±2</td> </tr> <tr> <td>Time (min.)</td> <td>30</td> <td>5 max.</td> <td>30</td> <td>5 max.</td> </tr> </tbody> </table> <p>Table 2: One cycle of temperature cycle</p>	Sequence	1	2	3	4	Temperature (°C)	-40±3	+25±2	+85±3	+25±2	Time (min.)	30	5 max.	30	5 max.
Sequence	1	2	3	4													
Temperature (°C)	-40±3	+25±2	+85±3	+25±2													
Time (min.)	30	5 max.	30	5 max.													
4	Humidity	<p>The rotary position sensor should be stored in a chamber at temperature of +60±2°C and relative Humidity of 90-95% for 250±8 hrs. After removing from the chamber, the rotary position sensor should be kept in the dry box for 24 +8/-0 hours.</p>															
5	Vibration	<p>The rotary position sensor should be tested under the condition of the amplitude of 1.5mm, the frequency range from 10 to 55Hz (should be traversed in approximately one minute) and 2 hours in each of 3 mutually perpendicular directions (total 6 hours). Then, the rotary position sensor should be kept in the dry box for 1-2 hrs.</p>															
6	Shock	<p>The rotary position sensor should be tested under the condition of the peak acceleration 20G max. in half-sine wave and 5 shocks in each of 3 mutually perpendicular directions (total 15 shocks). Then, the rotary position sensor should be kept in the dry box for 1-2 hrs.</p>															
7	Humidity Load Life	<p>Full rated continuous working voltage not exceeding 5Vdc should be applied intermittently between terminal #1 and terminal #3 of the rotary position sensor, 1.5 hours on and 0.5 hours off, for 96±4 hours in total in a chamber at a temperature of +40±2°C and relative humidity of 90-95%. After removing from the chamber, the rotary position sensor should be kept in the dry box for 24 +8/-0 hours.</p>															
8	High Temp. Exposure	<p>The rotary position sensor should be stored in a chamber at the temperature of +85±3°C without loading for 250±8 hours. After removing from the chamber, the rotary position sensor should be kept in the dry box for 24 +8/-0 hours.</p>															
9	Low Temp. Exposure	<p>The rotary position sensor should be stored in a chamber at the temperature of -40±3°C without loading for 168±4 hours. After removing from the chamber, the rotary position sensor should be kept in the dry box for 24 +8/-0 hours.</p>															
10	Rotational Life	<p>The adjustment rotor should be continuously rotated within ±160° of effective electrical rotational angle, at the rate of one cycle for 6 seconds for 1 Million cycles under the condition of +25±2°C of temperature without loading.</p>															

## Packaging

### ■ Minimum Quantity

Part Number	Minimum Quantity (pcs.)					
	ø180mm reel	ø330mm reel	Ammo Pack	Magazine	Bulk	Tray
PVZ2A	3000	12000	—	—	1000	—
PVZ2K	3000	—	—	—	1000	—
PVZ3A	2000	8000	—	—	1000	—
PVZ3K/R	1500	—	—	—	1000	—
PVS3	2500	8000	—	—	500	—
PVA3	2000	8000	—	—	500	—
PVG3A/G	1000	—	—	—	500	—
PVG3K	500	—	—	—	—	—
PVM4	500	3000	—	—	500	—
PVF2A	500	—	—	—	100	—
PVG5A	250	—	—	—	50	—
PVG5H	500	—	—	—	50	—
PV01W	—	—	—	50	—	—
PV01P	—	—	—	50	—	—
PV01X	—	—	—	50	—	—
PVC6A/D/G/H/E	—	—	—	50	50	—
PVC6M/Q	—	—	1000	50	50	—
PV34	—	—	—	—	100	—
PV32	—	—	—	—	100	—
PV23/12	—	—	—	—	50	—
PV22	—	—	—	—	30	—
PV36W	—	—	1000	50	50	—
PV36Y	—	—	—	50	50	—
PV36X	—	—	1000	40	50	—
PV36Z/P	—	—	—	40	50	—
PV37Y/Z	—	—	1000	—	50	—
PV37W/X/P	—	—	—	—	50	—
PVS1A	—	1000	—	—	50	—
PVS1L	—	—	—	—	—	1000

### ■ Dimensions of Reel

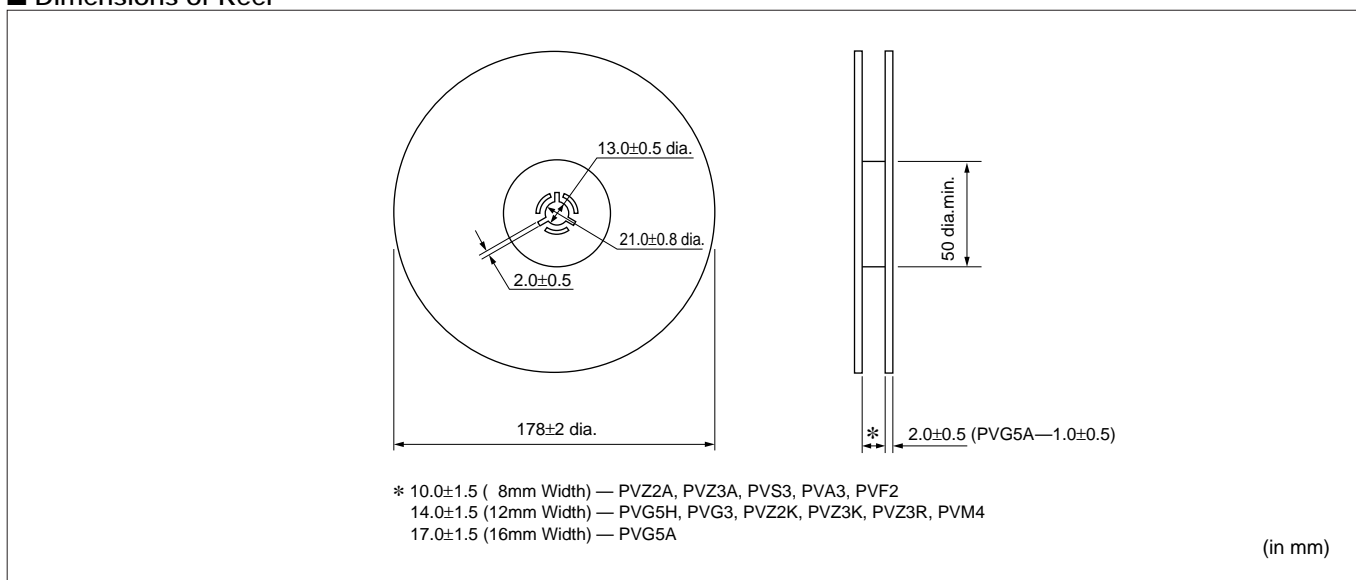

Continued on the following page. ↗

## Packaging

☞ Continued from the preceding page.

### ■ Dimensions of Reel

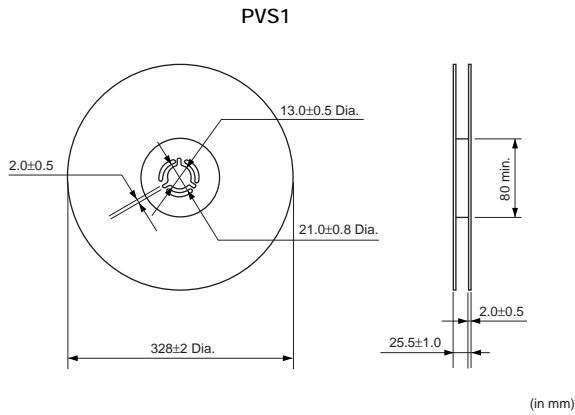

### ■ Dimensions of Plastic Tape

#### PVZ2 / PVZ3 / PVA3 / PVS3 / PVF2

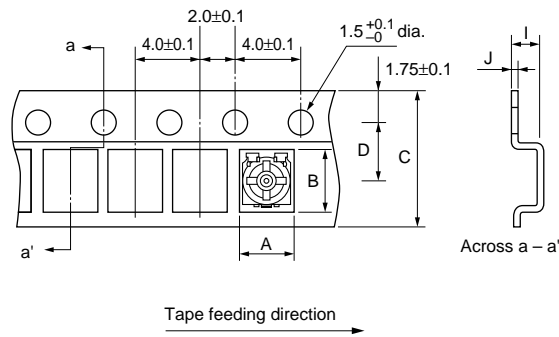

Part Number	A	B	C	D	I	J
PVZ2A	$2.4 \pm 0.1$	$3.1 \pm 0.1$	$8.0 \pm 0.2$	$3.5 \pm 0.1$	$1.1 \pm 0.1$	$0.2 \pm 0.1$
PVZ2K		$5.7 \pm 0.1$	$12.0 \pm 0.1$	$5.5 \pm 0.1$		$0.3 \pm 0.1$
PVZ3A/PVA3	$3.3 \pm 0.2$	$3.8 \pm 0.2$	$8.0 \pm 0.2$	$3.5 \pm 0.1$	$1.95 \pm 0.1$	$0.2 \pm 0.1$
PVZ3K		$5.8 \pm 0.2$	$12.0 \pm 0.2$	$5.5 \pm 0.1$		$2.3 \pm 0.1$
PVZ3R		$6.5 \pm 0.2$				$2.1 \pm 0.1$
PVS3	$2.3 \pm 0.2$	$4.1 \pm 0.2$	$8.0 \pm 0.2$	$3.5 \pm 0.1$	$1.6 \pm 0.1$	$0.2 \pm 0.1$
PVF2		$2.3 \pm 0.2$				$2.3 \pm 0.1$

• The side containing terminals #1 and #3 faces the plastic tape pilot holes.

(in mm)

Continued on the following page. ☞

## Packaging

Continued from the preceding page.

### ■ Dimensions of Plastic Tape

#### PVG3A / PVG3G / PVM4 / PVG5H

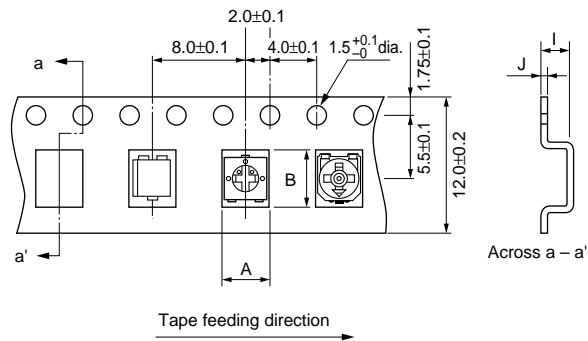

Part Number	A	B	I	J
<b>PVG3A</b>	4.0±0.1	4.0±0.1	2.1±0.1	0.3±0.1
<b>PVG3G</b>		4.9±0.1		
<b>PVM4</b>	4.5±0.2	5.5±0.2	2.15±0.1	0.3±0.1
<b>PVG5H</b>	5.4±0.2	5.8±0.2	4.0±0.1	0.4±0.1

• The side containing terminals #1 and #3 faces the plastic tape pilot holes (except PVG3).

(in mm)

#### PVG5A

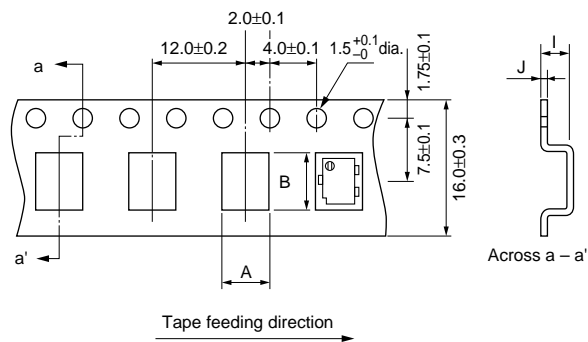

Part Number	A	B	I	J
<b>PVG5A</b>	4.3±0.2	5.4±0.2	5.4±0.1	0.4±0.1

(in mm)

Continued on the following page. ↗

## Packaging

☐ Continued from the preceding page.

### ■ Dimensions of Plastic Tape

PVG3K

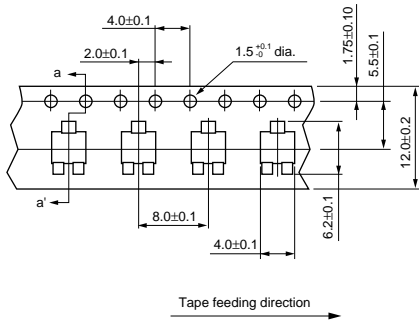

(in mm)

PVS1

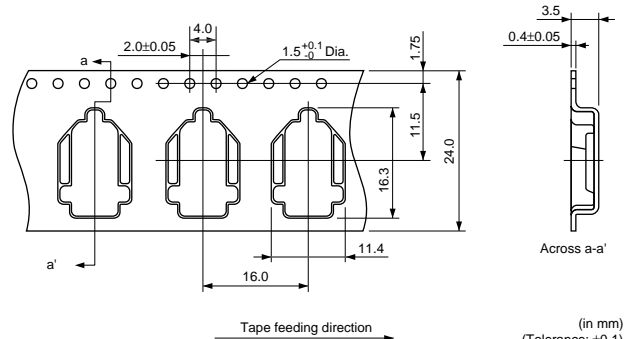

(in mm)  
(Tolerance: ±0.1)

### ■ Dimensions of Radial Taping

PVC6M

0.55W×3.2L×1.3D

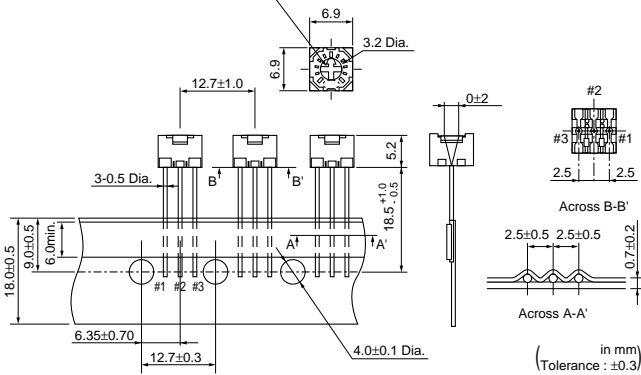

(in mm)  
(Tolerance: ±0.3)

PVC6Q

0.55W×3.2L×1.3D

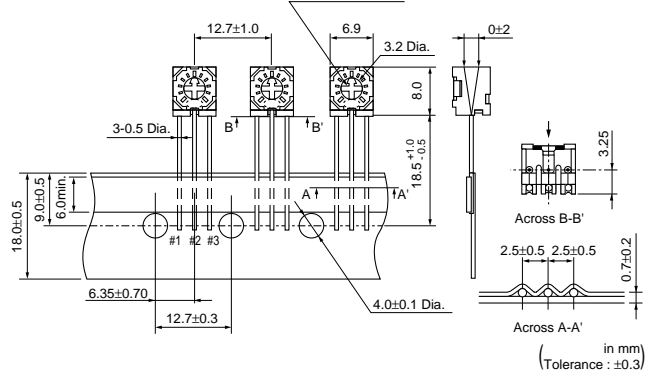

(in mm)  
(Tolerance: ±0.3)

PV37Y

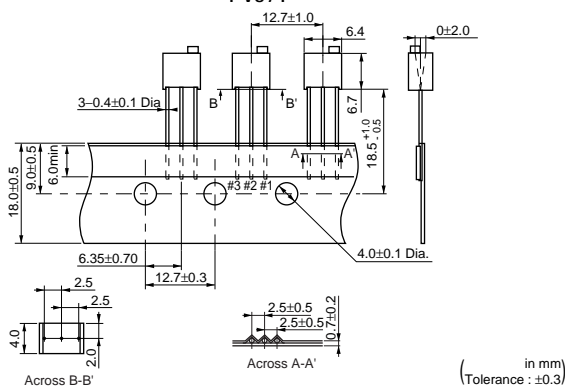

(in mm)  
(Tolerance: ±0.3)

PV37Z

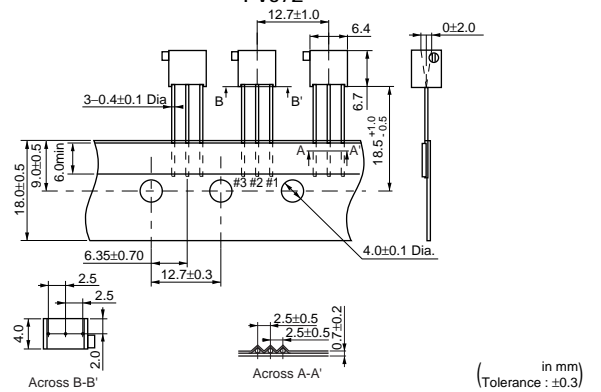

(in mm)  
(Tolerance: ±0.3)

☐ Continued on the following page.

## Packaging

Continued from the preceding page.

### ■ Dimensions of Radial Taping

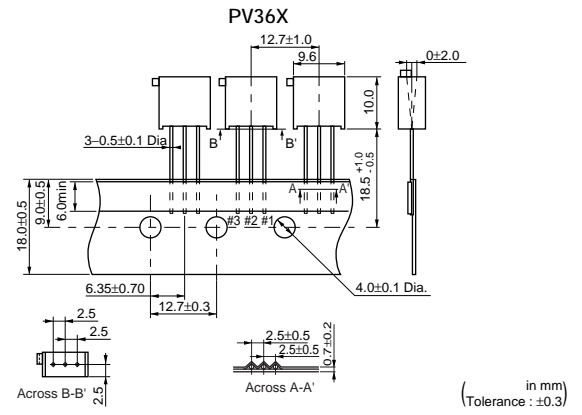
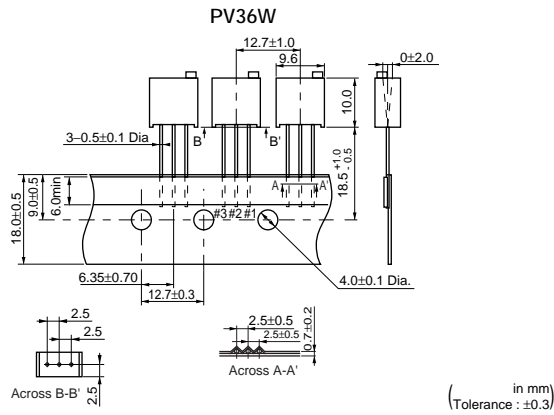

### ■ Dimensions of Ammo Pack

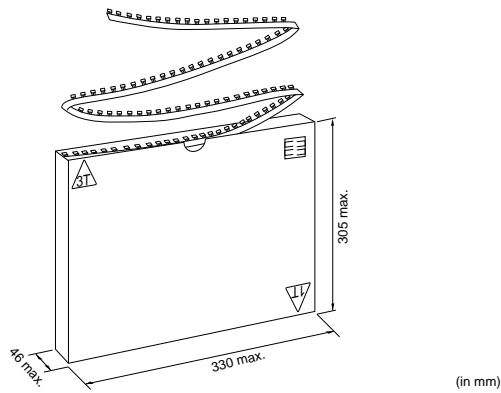

### ■ Dimensions of Magazine Packaging

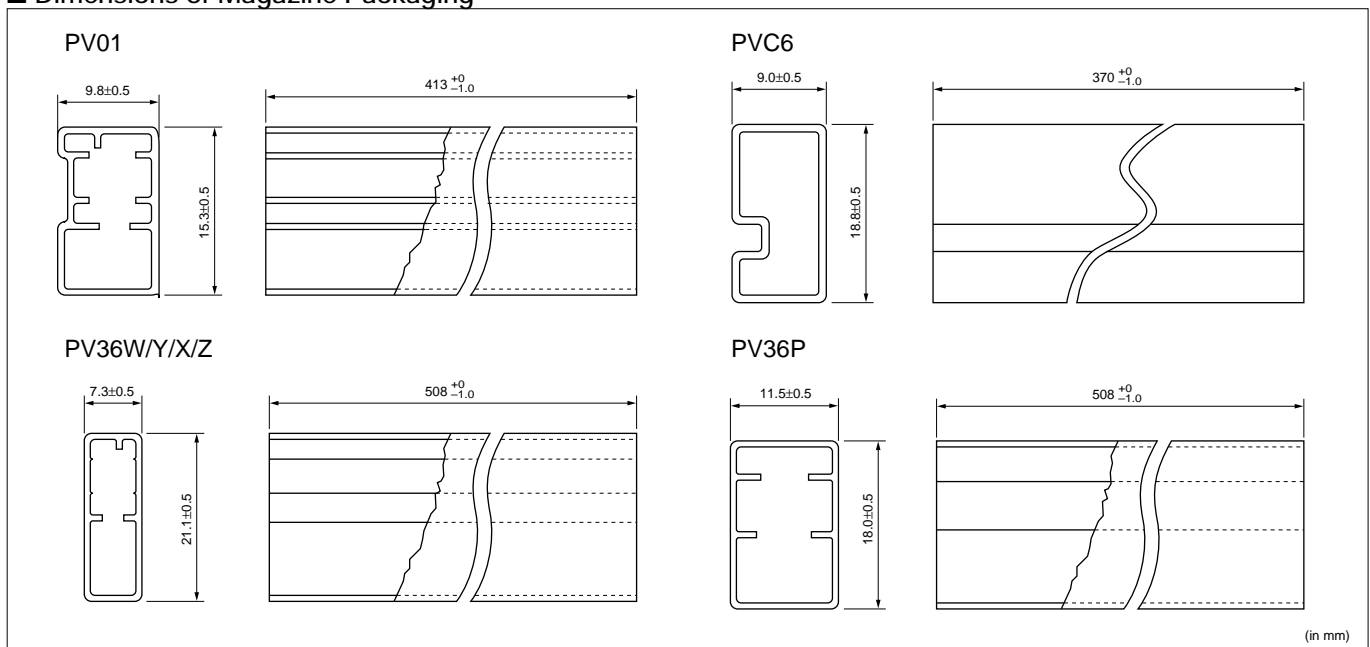



## Recommended Adjustment Tools/Qualified Standards

### ■ Recommended Adjustment Tools

Trimmer Potentiometer Series	Manufacturers	Model Number	MURATA Model Number	Blade
<b>PVZ2</b>	MURATA MFG.	KMDR090	KMDR090	- Minus (round edge)
<b>PVZ2A_A04</b>	VESSEL MFG.	No.9000+0X30	KMDR150	+ Cross
<b>PVZ3</b>	VESSEL MFG.	No.9000+1.7X30	KMDR080	+ Cross
	TORAY INDUSTRIES, INC.	SA-2225	KMDR070	- Minus (round edge)
<b>PVA3</b>	VESSEL MFG.	No.9000+1.7X30	KMDR080	+ Cross
	TORAY INDUSTRIES, INC.	SA-2225	KMDR070	- Minus (round edge)
<b>PVS3</b>	TORAY INDUSTRIES, INC.	SA-2225	KMDR070	- Minus (round edge)
<b>PVG3</b>	TORAY INDUSTRIES, INC.	SA-2225	KMDR070	- Minus (round edge)
<b>PVM4</b>	VESSEL MFG.	No.9000-2.6X30	KMDR120	- Minus
<b>PVG5</b>	VESSEL MFG.	No.9000-1.3X30	KMDR130	- Minus
	ENGINEER INC.	DA-54		- Minus
<b>PVC6</b>	VESSEL MFG.	No.9000+0X30	KMDR150	+ Cross
	TORAY INDUSTRIES, INC.	SA-2225	KMDR070	- Minus (round edge)
others	VESSEL MFG.	No.9000-1.8X30	KMDR110	- Minus
	ENGINEER INC.	DA-40	KMDR180	- Minus (both ends)
		DA-55		- Minus

### ■ For Automatic Adjustment

Trimmer Potentiometer Series	Manufacturers	Model Number	MURATA Model Number	Blade
<b>PVZ3</b> <b>PVA3</b> <b>PVS3</b> <b>PVG3</b>	TORAY INDUSTRIES, INC.	JB-2225	KMBT070	- Minus (round edge)
<b>PVC6</b>	VESSEL MFG.	No.CA-10	KMBT090	+ Cross
	TORAY INDUSTRIES, INC.	JB-2225	KMBT070	- Minus (round edge)

### ■ Qualified Standards

The products listed here have been produced by the QS9000 and ISO9001 certified factory.

MURATA FACTORY	Qualified Date	Standard	Qualified Number
Sabae Murata Mfg.Co.,Ltd.	August 14, 1997	UNDERWRITERS LABORATORIES INC.	A5704
Wuxi Murata Electronis Co.,Ltd.	May 12, 1999	UNDERWRITERS LABORATORIES INC.	A7924

\* No ODCs (Ozone Depleting Chemicals) are used on all Murata's trimmer potentiometers.

**⚠Note:**

1. Export Control

⟨For customers outside Japan⟩

Murata products should not be used or sold for use in the development, production, stockpiling or utilization of any conventional weapons or mass-destructive weapons (nuclear weapons, chemical or biological weapons, or missiles), or any other weapons.

⟨For customers in Japan⟩

For products which are controlled items subject to the "Foreign Exchange and Foreign Trade Law" of Japan, the export license specified by the law is required for export.

2. Please contact our sales representatives or product engineers before using the products in this catalog for the applications listed below, which require especially high reliability for the prevention of defects which might directly damage to a third party's life, body or property, or when one of our products is intended for use in applications other than those specified in this catalog.

- |                             |   |
|-----------------------------|---|
| ① Aircraft equipment        | ② Aerospace equipment   |
| ③ Undersea equipment        | ④ Power plant equipment   |
| ⑤ Medical equipment         | ⑥ Transportation equipment (vehicles, trains, ships, etc.)  |
| ⑦ Traffic signal equipment  | ⑧ Disaster prevention / crime prevention equipment  |
| ⑨ Data-processing equipment | ⑩ Application of similar complexity and/or reliability requirements to the applications listed in the above |

3. Product specifications in this catalog are as of April 2004. They are subject to change or our products in it may be discontinued without advance notice. Please check with our sales representatives or product engineers before ordering. If there are any questions, please contact our sales representatives or product engineers.

4. Please read rating and ⚠CAUTION (for storage, operating, rating, soldering, mounting and handling) in this catalog to prevent smoking and/or burning, etc.

5. This catalog has only typical specifications because there is no space for detailed specifications. Therefore, please approve our product specifications or transact the approval sheet for product specifications before ordering.

6. Please note that unless otherwise specified, we shall assume no responsibility whatsoever for any conflict or dispute that may occur in connection with the effect of our and/or a third party's intellectual property rights and other related rights in consideration of your use of our products and/or information described or contained in our catalogs. In this connection, no representation shall be made to the effect that any third parties are authorized to use the rights mentioned above under licenses without our consent.

7. No ozone depleting substances (ODS) under the Montreal Protocol are used in our manufacturing process.

# Mouser Electronics

Authorized Distributor

Click to View Pricing, Inventory, Delivery & Lifecycle Information:

## Murata:

[PVZ3A104A01B00](#) [PV32H500A01B00](#) [PV32H504A01B00](#) [PV32H503A01B00](#) [PV32H505A01B00](#)  
[PV32H501A01B00](#) [PV32H105A01B00](#) [PV32H101A01B00](#) [PV32H103A01B00](#) [PV32H102A01B00](#) [PV32H104A01B00](#)  
[PV32H100A01B00](#) [PV12S205A01B00](#) [PV12S201A01B00](#) [PV12S203A01B00](#) [PV12S202A01B00](#)  
[PV12S204A01B00](#) [PV12S200A01B00](#) [PV36X202A01B00](#) [PV36X200A01B00](#) [PV36X204A01B00](#) [PV36X203A01B00](#)  
[PV36X205A01B00](#) [PV36X201A01B00](#) [PV36X253A01B00](#) [PV36X254A01B00](#) [PVZ2K303A01R00](#)  
[PVZ2K302A01R00](#) [PVZ2K304A01R00](#) [PV32P253A02B00](#) [PV32P254A02B00](#) [PV32P201A02B00](#) [PV32P205A02B00](#)  
[PV32P203A02B00](#) [PV32P202A02B00](#) [PV32P200A02B00](#) [PV32P204A02B00](#) [PVZ2K501A01R00](#)  
[PVZ2K503A01R00](#) [PVZ2K502A01R00](#) [PVZ2K504A01R00](#) [PVZ2K102A01R00](#) [PVZ2K104A01R00](#)  
[PVZ2K103A01R00](#) [PVZ2K105A01R00](#) [PV36Z254A01B00](#) [PV36Z253A01B00](#) [PV36Z200A01B00](#) [PV36Z204A01B00](#)  
[PV36Z202A01B00](#) [PV36Z205A01B00](#) [PV36Z201A01B00](#) [PV36Z203A01B00](#) [PV12H102A01B00](#) [PV12H104A01B00](#)  
[PV12H100A01B00](#) [PV12H103A01B00](#) [PV12H101A01B00](#) [PV12H105A01B00](#) [PV12H500A01B00](#)  
[PV12H504A01B00](#) [PV12H502A01B00](#) [PV12H501A01B00](#) [PV12H503A01B00](#) [PVG5A205A01R00](#)  
[PVG5A201A01R00](#) [PVG5A203A01R00](#) [PVG5A202A01R00](#) [PVG5A204A01R00](#) [PVG5A200A01R00](#)  
[PVG5A203A01B00](#) [PVG5A201A01B00](#) [PVG5A205A01B00](#) [PVG5A204A01B00](#) [PVG5A200A01B00](#)  
[PVG5A202A01B00](#) [PV36Z502A01B00](#) [PV36Z500A01B00](#) [PV36Z504A01B00](#) [PV36Z503A01B00](#) [PV36Z501A01B00](#)  
[PV36Z105A01B00](#) [PV36Z103A01B00](#) [PV36Z102A01B00](#) [PV36Z104A01B00](#) [PV36Z100A01B00](#) [PVG5A104A01B00](#)  
[PVG5A504A01R00](#) [PVG5A100A01B00](#) [PVG5A500A01R00](#) [PVG5A102A01B00](#) [PVG5A502A01R00](#)  
[PVG5A101A01B00](#) [PVG5A501A01R00](#) [PVG5A105A01B00](#) [PVG5A103A01B00](#) [PVG5A503A01R00](#)  
[PV12H202A01B00](#) [PV12H204A01B00](#) [PV12H200A01B00](#)