

Distributed by:

**JAMECO**<sup>®</sup>  
ELECTRONICS

**www.Jameco.com ♦ 1-800-831-4242**

The content and copyrights of the attached  
material are the property of its owner.

Jameco Part Number 1531153

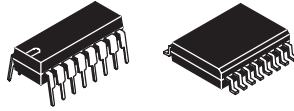

## HIGH-SPEED PWM CONTROLLER

### FEATURES

- Improved Versions of the UC3823/UC3825 PWMs
- Compatible with Voltage-Mode or Current-Mode Control Methods
- Practical Operation at Switching Frequencies to 1 MHz
- 50-ns Propagation Delay to Output
- High-Current Dual Totem Pole Outputs (2-A Peak)
- Trimmed Oscillator Discharge Current
- Low 100- $\mu$ A Startup Current
- Pulse-by-Pulse Current Limiting Comparator
- Latched Overcurrent Comparator With Full Cycle Restart

### DESCRIPTION

The UC3823A and UC3823B and the UC3825A and UC3825B family of PWM controllers are improved versions of the standard UC3823 and UC3825 family. Performance enhancements have been made to several of the circuit blocks. Error amplifier gain bandwidth product is 12 MHz, while input offset voltage is 2 mV. Current limit threshold is assured to a tolerance of 5%. Oscillator discharge current is specified at 10 mA for accurate dead time control. Frequency accuracy is improved to 6%. Startup supply current, typically 100  $\mu$ A, is ideal for off-line applications. The output drivers are redesigned to actively sink current during UVLO at no expense to the startup current specification. In addition each output is capable of 2-A peak currents during transitions.

### BLOCK DIAGRAM

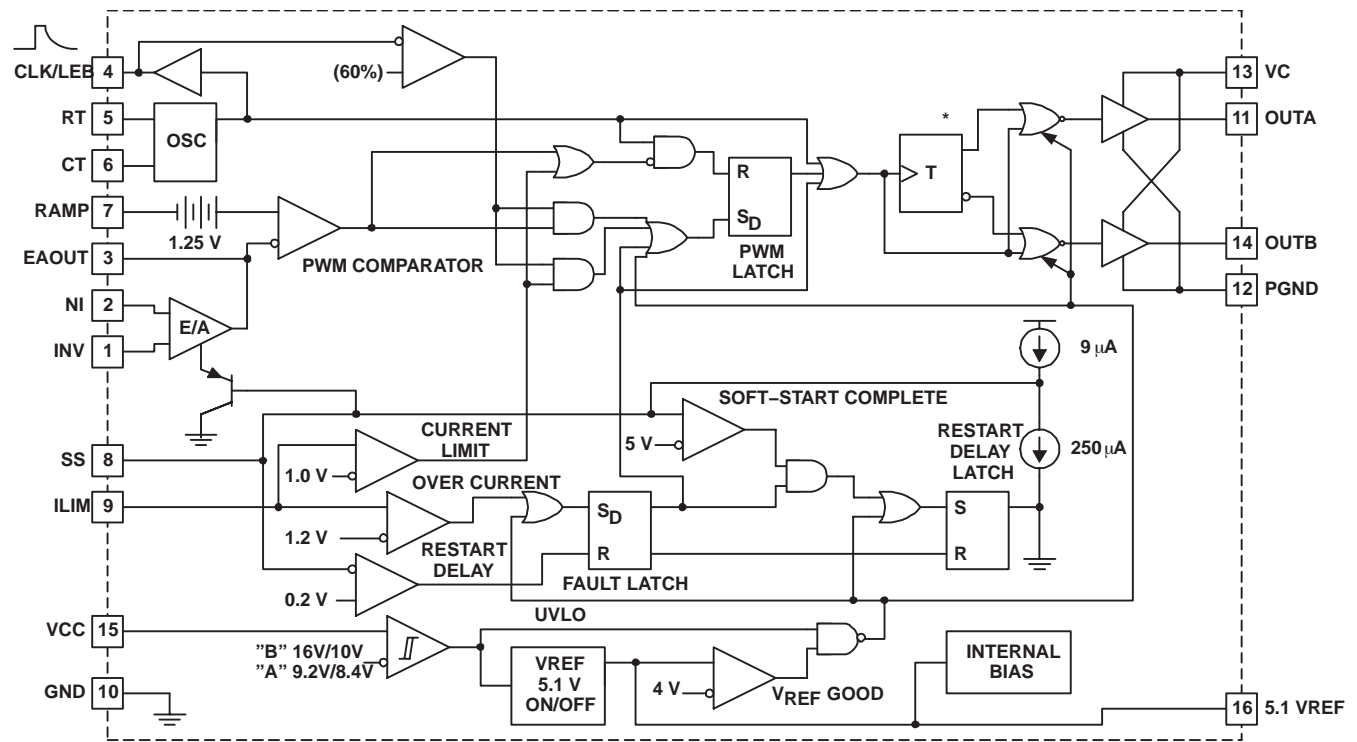

\* On the UC1823A version, toggles Q and  $\bar{Q}$  are always low.

UDG-02091



Please be aware that an important notice concerning availability, standard warranty, and use in critical applications of Texas Instruments semiconductor products and disclaimers thereto appears at the end of this data sheet.



These devices have limited built-in ESD protection. The leads should be shorted together or the device placed in conductive foam during storage or handling to prevent electrostatic damage to the MOS gates.

## DESCRIPTION (CONTINUED)

Functional improvements have also been implemented in this family. The UC3825 shutdown comparator is now a high-speed overcurrent comparator with a threshold of 1.2 V. The overcurrent comparator sets a latch that ensures full discharge of the soft-start capacitor before allowing a restart. While the fault latch is set, the outputs are in the low state. In the event of continuous faults, the soft-start capacitor is fully charged before discharge to insure that the fault frequency does not exceed the designed soft start period. The UC3825 CLOCK pin has become CLK/LEB. This pin combines the functions of clock output and leading edge blanking adjustment and has been buffered for easier interfacing.

The UC3825A and UC3825B have dual alternating outputs and the same pin configuration of the UC3825. The UC3823A and UC3823B outputs operate in phase with duty cycles from zero to less than 100%. The pin configuration of the UC3823A and UC3823B is the same as the UC3823 except pin 11 is now an output pin instead of the reference pin to the current limit comparator. "A" version parts have UVLO thresholds identical to the original UC3823 and UC3825. The "B" versions have UVLO thresholds of 16 V and 10 V, intended for ease of use in off-line applications.

Consult the application note, *The UC3823A,B and UC3825A,B Enhanced Generation of PWM Controllers*, (SLUA125) for detailed technical and applications information.

## ORDERING INFORMATION

T <sub>A</sub>	MAXIMUM DUTY CYCLE	UVLO					
		9.2 V / 8.4 V			16 V / 10 V		
		SOIC-16 <sup>(1)</sup> (DW)	PDIP-16 (N)	PLCC-20 <sup>(1)</sup> (Q)	SOIC-16 (DW)	PDIP-16 (N)	PLCC-20 <sup>(1)</sup> (Q)
-40°C to 85°C	< 100%	UC2823ADW	UC2823AN	UC2823AQ	UC2823BDW	UC2823BN	–
	< 50%	UC2825ADW	UC2825AN	UC2825AQ	UC2825BDW	UC2825BN	–
-0°C to 70°C	< 100%	UC3823ADW	UC3823AN	UC3823AQ	UC3823BDW	UC3823BN	–
	< 50%	UC3825ADW	UC3825AN	UC3825AQ	UC3825BDW	UC3825BN	UC3825BQ

(1) The DW and Q packages are also available taped and reeled. Add TR suffix to the device type (i.e., UC2823ADWR). To order quantities of 1000 devices per reel for the Q package and 2000 devices per reel for the DW package.

T <sub>A</sub>	MAXIMUM DUTY CYCLE	UVLO	
		9.2 V / 8.4 V	
		CDIP-16 (J)	LCC-20 (L)
-55°C to 125°C	< 100%	UC1823AJ, UC1823AJ883B, UC1823AJQMLV	UC1823AL, UC1823AL883B
	< 50%	UC1825AJ, UC1825AJ883B, UC1825AJQMLV	UC1825AL, UC1825AL883B, UC1825ALQMLV

## PIN ASSIGNMENTS

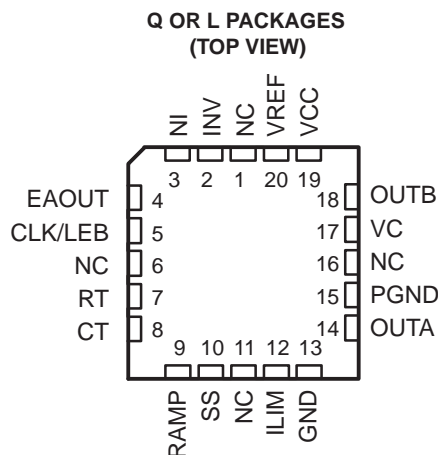
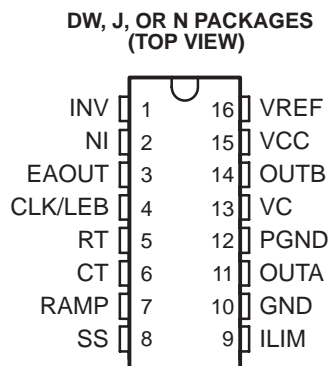

NC = no connection

## TERMINAL FUNCTIONS

NAME	TERMINAL NO.		I/O	DESCRIPTION
	J or DW	Q or L		
CLK/LEB	4	5	O	Output of the internal oscillator
CT	6	8	I	Timing capacitor connection pin for oscillator frequency programming. The timing capacitor should be connected to the device ground using minimal trace length.
EAOUT	3	4	O	Output of the error amplifier for compensation
GND	10	13	–	Analog ground return pin
ILIM	9	12	I	Input to the current limit comparator
INV	1	2	I	Inverting input to the error amplifier
NI	2	3	I	Non-inverting input to the error amplifier
OUTA	11	14	O	High current totem pole output A of the on-chip drive stage.
OUTB	14	18	O	High current totem pole output B of the on-chip drive stage.
PGND	12	15	–	Ground return pin for the output driver stage
RAMP	7	9	I	Non-inverting input to the PWM comparator with 1.25-V internal input offset. In voltage mode operation, this serves as the input voltage feed-forward function by using the CT ramp. In peak current mode operation, this serves as the slope compensation input.
RT	5	7	I	Timing resistor connection pin for oscillator frequency programming
SS	8	10	I	Soft-start input pin which also doubles as the maximum duty cycle clamp.
VC	13	17	–	Power supply pin for the output stage. This pin should be bypassed with a 0.1- $\mu$ F monolithic ceramic low ESL capacitor with minimal trace lengths.
VCC	15	19	–	Power supply pin for the device. This pin should be bypassed with a 0.1- $\mu$ F monolithic ceramic low ESL capacitor with minimal trace lengths
VREF	16	20	O	5.1-V reference. For stability, the reference should be bypassed with a 0.1- $\mu$ F monolithic ceramic low ESL capacitor and minimal trace length to the ground plane.

## ABSOLUTE MAXIMUM RATINGS

over operating free-air temperature range unless otherwise noted<sup>(1)</sup>

		UNIT	
$V_{IN}$	Supply voltage,	VC, VCC	22 V
$I_O$	Source or sink current, DC	OUTA, OUTB	0.5 A
$I_O$	Source or sink current, pulse (0.5 $\mu$ s)	OUTA, OUTB	2.2 A
	Analog inputs	INV, NI, RAMP	–0.3 V to 7 V
		ILIM, SS	–0.3 V to 6 V
	Power ground	PGND	$\pm 0.2$ V
$I_{CLK}$	Clock output current	CLK/LEB	–5 mA
$I_{O(EA)}$	Error amplifier output current	EAOUT	5 mA
$I_{SS}$	Soft-start sink current	SS	20 mA
$I_{OSC}$	Oscillator charging current	RT	–5 mA
$T_J$	Operating virtual junction temperature range		–55°C to 150°C
$T_{stg}$	Storage temperature		–65°C to 150°C
	Lead temperature 1,6 mm (1/16 inch) from case for 10 seconds		–55°C to 150°C
$t_{STG}$	Storage temperature		–65°C to 150°C
	Lead temperature 1,6 mm (1/16 inch) from cases for 10 seconds		300°C

(1) Stresses beyond those listed under “absolute maximum ratings” may cause permanent damage to the device. These are stress ratings only, and functional operation of the device at these or any other conditions beyond those indicated under “recommended operating conditions” is not implied. Exposure to absolute-maximum-rated conditions for extended periods may affect device reliability.

## ELECTRICAL CHARACTERISTICS

$T_A = -55^\circ\text{C}$  to  $125^\circ\text{C}$  for the UC1823A/UC1825A,  $T_A = -40^\circ\text{C}$  to  $85^\circ\text{C}$  for the UC2823x/UC2825x,  $T_A = 0^\circ\text{C}$  to  $70^\circ\text{C}$  for the UC3823x/UC3825x,  $R_T = 3.65\text{ k}\Omega$ ,  $C_T = 1\text{ nF}$ ,  $V_{CC} = 12\text{ V}$ ,  $T_A = T_J$  (unless otherwise noted)

PARAMETER		TEST CONDITIONS	MIN	TYP	MAX	UNIT
<b>REFERENCE, V<sub>REF</sub></b>						
V <sub>O</sub>	Output voltage range	$T_J = 25^\circ\text{C}$ , $I_O = 1\text{ mA}$	5.05	5.1	5.15	V
	Line regulation	$12\text{ V} \leq V_{CC} \leq 20\text{ V}$		2	15	mV
	Load regulation	$1\text{ mA} \leq I_O \leq 10\text{ mA}$		5	20	
	Total output variation	Line, load, temperature	5.03		5.17	V
	Temperature stability <sup>(1)</sup>	$T_{(\text{min})} < T_A < T_{(\text{max})}$		0.2	0.4	mV/°C
	Output noise voltage <sup>(1)</sup>	$10\text{ Hz} < f < 10\text{ kHz}$		50		$\mu\text{VRMS}$
	Long term stability <sup>(1)</sup>	$T_J = 125^\circ\text{C}$ , 1000 hours		5	25	mV
	Short circuit current	$V_{REF} = 0\text{ V}$	30	60	90	mA
<b>OSCILLATOR</b>						
f <sub>OSC</sub>	Initial accuracy <sup>(1)</sup>	$T_J = 25^\circ\text{C}$	375	400	425	kHz
		$R_T = 6.6\text{ k}\Omega$ , $C_T = 220\text{ pF}$ , $T_A = 25^\circ\text{C}$	0.9	1	1.1	MHz
	Total variation <sup>(1)</sup>	Line, temperature			450	kHz
		$R_T = 6.6\text{ k}\Omega$ , $C_T = 220\text{ pF}$ ,	0.85		1.15	MHz
	Voltage stability	$12\text{ V} < V_{CC} < 20\text{ V}$			1%	
	Temperature stability <sup>(1)</sup>	$T_{(\text{min})} < T_A < T_{(\text{max})}$	+/-	5%		
	High-level output voltage, clock		3.7	4		V
	Low-level output voltage, clock			0	0.2	
	Ramp peak		2.6	2.8	3	
	Ramp valley		0.7	1	1.25	
	Ramp valley-to-peak		1.6	1.8	2	
	Oscillator discharge current	$R_T = \text{OPEN}$ , $V_{CT} = 2\text{ V}$	9	10	11	
<b>ERROR AMPLIFIER</b>						
	Input offset voltage			2	10	mV
	Input bias current			0.6	3	$\mu\text{A}$
	Input offset current			0.1	1	
	Open loop gain	$1\text{ V} < V_O < 4\text{ V}$	60	95		dB
CMRR	Common mode rejection ratio	$1.5\text{ V} < V_{CM} < 5.5\text{ V}$	75	95		
PSRR	Power supply rejection ratio	$12\text{ V} < V_{CC} < 20\text{ V}$	85	110		
I <sub>O(sink)</sub>	Output sink current	$V_{EAOUT} = 1\text{ V}$	1	2.5		mA
I <sub>O(src)</sub>	Output source current	$V_{EAOUT} = 4\text{ V}$	-0.5	-1.3		
	High-level output voltage	$I_{EAOUT} = -0.5\text{ mA}$	4.5	4.7	5	V
	Low-level output voltage	$I_{EAOUT} = -1\text{ mA}$	0	0.5	1	
	Gain bandwidth product	$f = 200\text{ kHz}$	6	12		Mhz
	Slew rate <sup>(1)</sup>		6	9		V/ $\mu\text{s}$

(1) Ensured by design. Not production tested.

**ELECTRICAL CHARACTERISTICS**
 $T_A = -55^\circ\text{C}$  to  $125^\circ\text{C}$  for the UC1823A/UC1825A,  $T_A = -40^\circ\text{C}$  to  $85^\circ\text{C}$  for the UC2823x/UC2825x,  $T_A = 0^\circ\text{C}$  to  $70^\circ\text{C}$  for the UC3823x/UC3825x,  $R_T = 3.65\text{ k}\Omega$ ,  $C_T = 1\text{ nF}$ ,  $V_{CC} = 12\text{ V}$ ,  $T_A = T_J$  (unless otherwise noted)

<b>PWM COMPARATOR</b>						
$I_{BIAS}$	Bias current, RAMP	$V_{RAMP} = 0\text{ V}$	-1	-8		$\mu\text{A}$
	Minimum duty cycle			0%		
	Maximum duty cycle		85%			
$t_{LEB}$	Leading edge blanking time	$R_{LEB} = 2\text{ k}\Omega$ , $C_{LEB} = 470\text{ pF}$	300	375	450	ns
$R_{LEB}$	Leading edge blanking resistance	$V_{CLK/LEB} = 3\text{ V}$	8.5	10.0	11.5	$\text{k}\Omega$
$V_{ZDC}$	Zero dc threshold voltage, EAOUT	$V_{RAMP} = 0\text{ V}$	1.10	1.25	1.4	V
$t_{DELAY}$	Delay-to-output time	$V_{EAOUT} = 2.1\text{ V}$ , $V_{ILIM} = 0\text{ V}$ to $2\text{ V}$ step		50	80	ns
<b>CURRENT LIMIT / START SEQUENCE / FAULT</b>						
$I_{SS}$	Soft-start charge current	$V_{SS} = 2.5\text{ V}$	8	14	20	$\mu\text{A}$
$V_{SS}$	Full soft-start threshold voltage		4.3	5		V
$I_{DSCH}$	Restart discharge current	$V_{SS} = 2.5\text{ V}$	100	250	350	$\mu\text{A}$
$I_{SS}$	Restart threshold voltage			0.3	0.5	V
$I_{BIAS}$	ILIM bias current	$V_{ILIM} = 0\text{ V}$ to $2\text{ V}$ step			15	$\mu\text{A}$
$I_{CL}$	Current limit threshold voltage		0.95	1	1.05	V
	Overcurrent threshold voltage		1.14	1.2	1.26	
$t_d$	Delay-to-output time, $I_{LIM}^{(1)}$	$V_{ILIM} = 0\text{ V}$ to $2\text{ V}$ step		50	80	ns
<b>OUTPUT</b>						
	Low-level output saturation voltage	$I_{OUT} = 20\text{ mA}$		0.25	0.4	V
		$I_{OUT} = 200\text{ mA}$		1.2	2.2	
	High-level output saturation voltage	$I_{OUT} = 20\text{ mA}$		1.9	2.9	
		$I_{OUT} = 200\text{ mA}$		2	3	
$t_r$ , $t_f$	Rise/fall time <sup>(1)</sup>	$C_L = 1\text{ nF}$		20	45	ns
<b>UNDERVOLTAGE LOCKOUT (UVLO)</b>						
	Start threshold voltage	UC2823B, UC2825B, UC3825B, UC3825B		16	17	V
		UC1823A, UC1825A, UC2823A, UC2825A UC3825A, UC3825A		8.4	9.2	
	Stop threshold voltage	UC2823B, UC2825B, UC3825B, UC3825B		9	10	
	OVLO hysteresis	UC1823A, UC1825A, UC2823A, UC2825A UC3825A, UC3825A		0.4	0.8	
		UC2823B, UC2825B, UC3825B, UC3825B		5	6	7
<b>SUPPLY CURRENT</b>						
$I_{su}$	Startup current	$V_C = V_{CC} = V_{TH} = -0.5\text{ V}$		100	300	$\mu\text{A}$
$I_{CC}$	Input current			28	36	mA

(1) Ensured by design. Not production tested.

### APPLICATION INFORMATION

The oscillator of the UC3823A, UC3823B, UC3825A, and UC3825B is a saw tooth. The rising edge is governed by a current controlled by the RT pin and value of capacitance at the CT pin ( $C_{CT}$ ). The falling edge of the sawtooth sets dead time for the outputs. Selection of RT should be done first, based on desired maximum duty cycle. CT can then be chosen based on the desired frequency (RT) and  $D_{MAX}$ . The design equations are:

$$R_T = \frac{3 \text{ V}}{(10 \text{ mA}) \times (1 - D_{MAX})} \quad C_T = \frac{(1.6 \times D_{MAX})}{(R_T \times f)} \quad (1)$$

Recommended values for  $R_T$  range from 1 k $\Omega$  to 100 k $\Omega$ . Control of  $D_{MAX}$  less than 70% is not recommended.

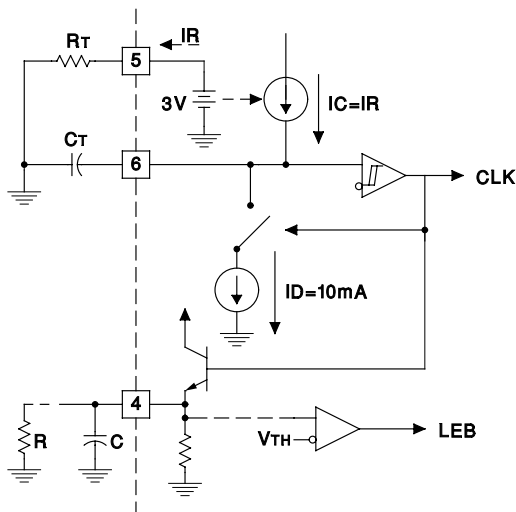

UDG-95102

Figure 1. Oscillator

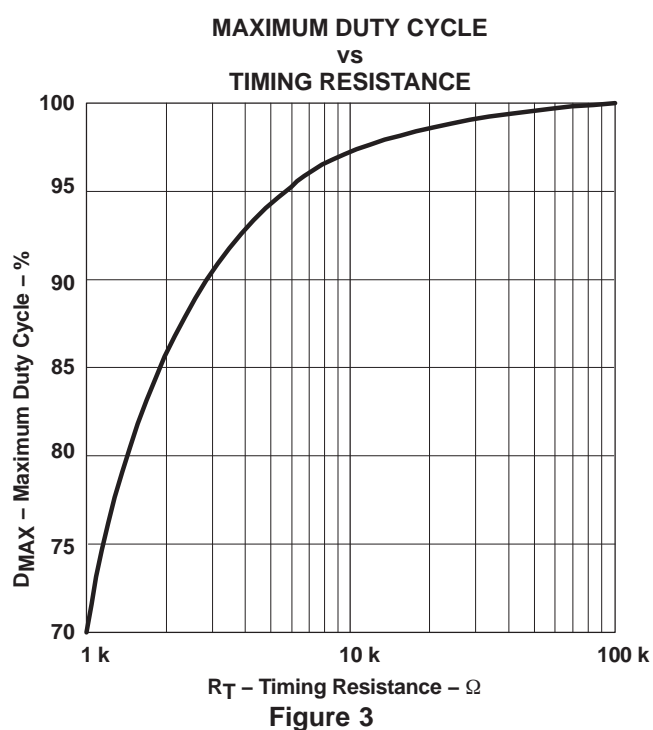
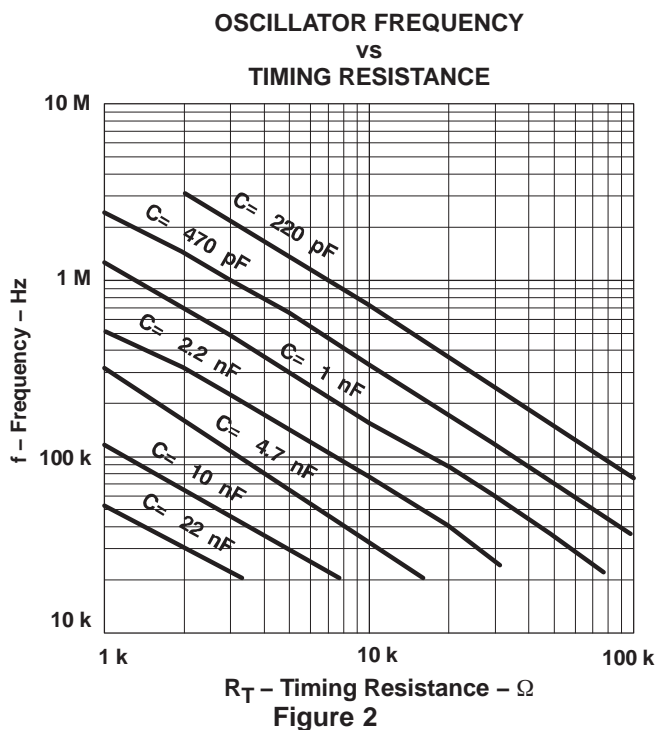

## LEADING EDGE BLANKING

The UC3823A, UC2823B, UC3825A, and UC3825B perform fixed frequency pulse width modulation control. The UC3823A, and UC3823B outputs operate together at the switching frequency and can vary from zero to some value less than 100%. The UC3825A and UC3825B outputs are alternately controlled. During every other cycle, one output is off. Each output then switches at one-half the oscillator frequency, varying in duty cycle from 0 to less than 50%.

To limit maximum duty cycle, the internal clock pulse blanks both outputs low during the discharge time of the oscillator. On the falling edge of the clock, the appropriate output(s) is driven high. The end of the pulse is controlled by the PWM comparator, current limit comparator, or the overcurrent comparator.

Normally the PWM comparator senses a ramp crossing a control voltage (error amplifier output) and terminates the pulse. Leading edge blanking (LEB) causes the PWM comparator to be ignored for a fixed amount of time after the start of the pulse. This allows noise inherent with switched mode power conversion to be rejected. The PWM ramp input may not require any filtering as result of leading edge blanking.

To program a leading edge blanking (LEB) period, connect a capacitor, C, to CLK/LEB. The discharge time set by C and the internal 10-kΩ resistor determines the blanked interval. The 10-kΩ resistor has a 10% tolerance. For more accuracy, an external 2-kΩ 1% resistor (R) can be added, resulting in an equivalent resistance of 1.66 kΩ with a tolerance of 2.4%. The design equation is:

$$t_{LEB} = 0.5 \times (R \parallel 10 \text{ k}\Omega) \times C \quad (2)$$

Values of R less than 2 kΩ should not be used.

Leading edge blanking is also applied to the current limit comparator. After LEB, if the ILIM pin exceeds the 1-V threshold, the pulse is terminated. The overcurrent comparator, however, is not blanked. It catches catastrophic overcurrent faults without a blanking delay. Any time the ILIM pin exceeds 1.2 V, the fault latch is set and the outputs driven low. For this reason, some noise filtering may be required on the ILIM pin.

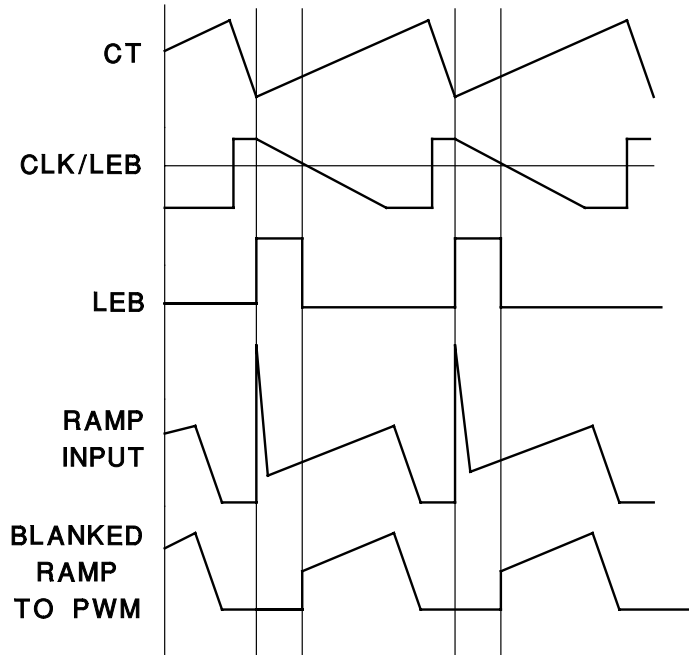

UDG-95105

Figure 4. Leading Edge Blanking Operational Waveforms



## UVLO, SOFT-START AND FAULT MANAGEMENT

Soft-start is programmed by a capacitor on the SS pin. At power up, SS is discharged. When SS is low, the error amplifier output is also forced low. While the internal 9- $\mu$ A source charges the SS pin, the error amplifier output follows until closed loop regulation takes over.

Anytime ILIM exceeds 1.2 V, the fault latch is set and the output pins are driven low. The soft-start cap is then discharged by a 250- $\mu$ A current sink. No more output pulses are allowed until soft-start is fully discharged and ILIM is below 1.2 V. At this point the fault latch resets and the chip executes a soft-start.

Should the fault latch get set during soft-start, the outputs are immediately terminated, but the soft-start capacitor does not discharge until it has been fully charged first. This results in a controlled hiccup interval for continuous fault conditions.

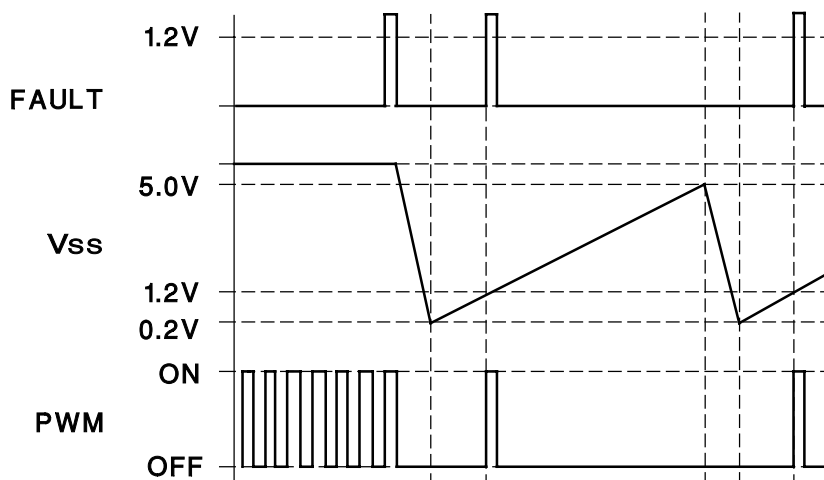

UDG-95106

Figure 5. Soft-Start and Fault Waveforms

## ACTIVE LOW OUTPUTS DURING UVLO

The UVLO function forces the outputs to be low and considers both VCC and VREF before allowing the chip to operate.

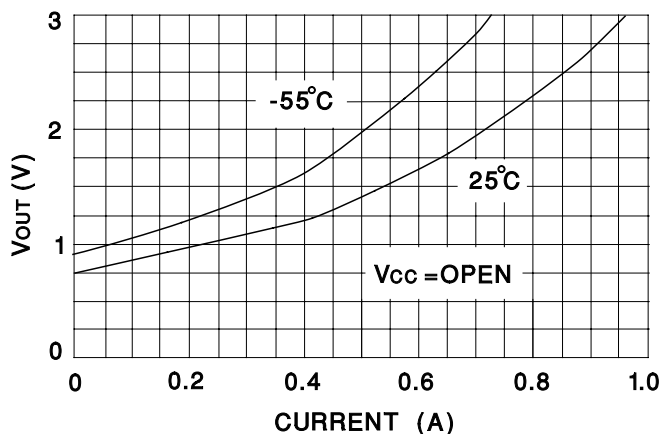

UDG-95108

Figure 6. Output Voltage vs Output Current

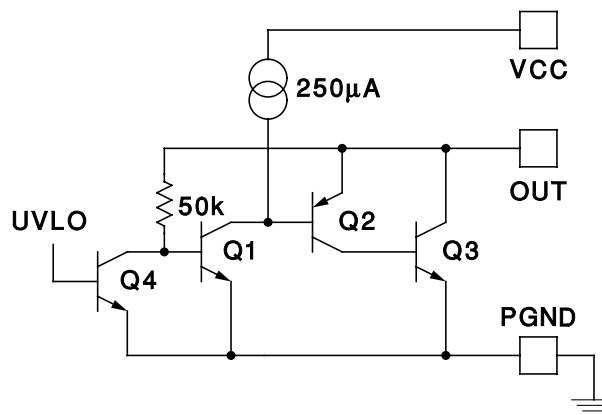

UDG-95106

Figure 7. Output V and I During UVLO

## CONTROL METHODS

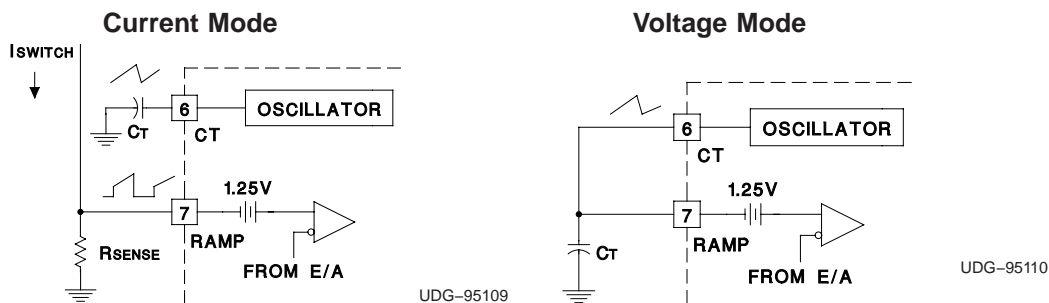

Figure 8. Control Methods

## SYNCHRONIZATION

The oscillator can be synchronized by an external pulse inserted in series with the timing capacitor. Program the free running frequency of the oscillator to be 10% to 15% slower than the desired synchronous frequency. The pulse width should be greater than 10 ns and less than half the discharge time of the oscillator. The rising edge of the CLK/LEB pin can be used to generate a synchronizing pulse for other chips. Note that the CLK/LEB pin no longer accepts an incoming synchronizing signal.

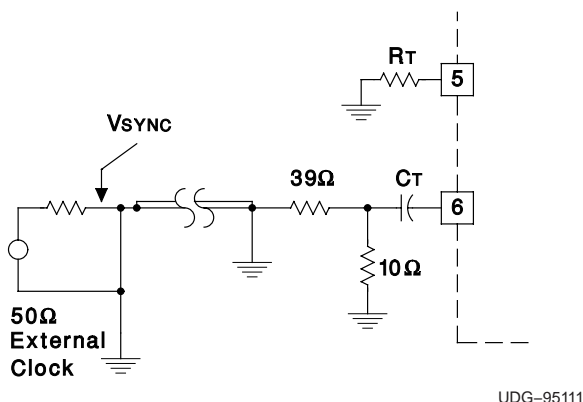

Figure 9. General Oscillator Synchronization

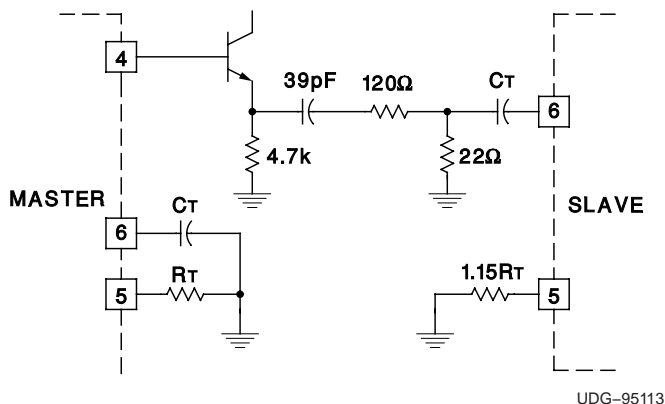
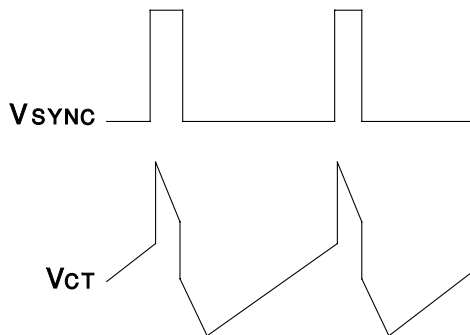

Figure 10. Two Unit Interface



UDG-95112

Figure 11. Operational Waveforms

## HIGH CURRENT OUTPUTS

Each totem pole output of the UC3823A and UC3823AB, UC3825A, and UC3825B can deliver a 2-A peak current into a capacitive load. The output can slew a 1000-pF capacitor by 15 V in approximately 20 ns. Separate collector supply (VC) and power ground (PGND) pins help decouple the device's analog circuitry from the high-power gate drive noise. The use of 3-A Schottky diodes (1N5120, USD245, or equivalent) as shown in the Figure 13 from each output to both VC and PGND are recommended. The diodes clamp the output swing to the supply rails, necessary with any type of inductive/capacitive load, typical of a MOSFET gate. Schottky diodes must be used because a low forward voltage drop is required. DO NOT USE standard silicon diodes.

Although they are *single-ended* devices, two output drivers are available on the UC3823A and UC3823B devices. These can be *paralleled* by the use of a 0.5  $\Omega$  (noninductive) resistor connected in series with each output for a combined peak current of 4 A.

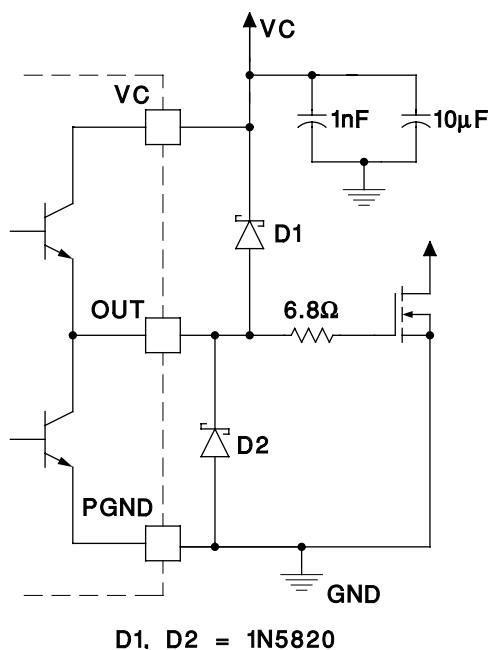

UDG-95114

Figure 12. Power MOSFET Drive Circuit

## GROUND PLANES

Each output driver of these devices is capable of 2-A peak currents. Careful layout is essential for correct operation of the chip. A ground plane must be employed. A unique section of the ground plane must be designated for high di/dt currents associated with the output stages. This point is the power ground to which the PGND pin is connected. Power ground can be separated from the rest of the ground plane and connected at a single point, although this is not necessary if the high di/dt paths are well understood and accounted for. VCC should be bypassed directly to power ground with a good high frequency capacitor. The sources of the power MOSFET should connect to power ground as should the return connection for input power to the system and the bulk input capacitor. The output should be clamped with a high current Schottky diode to both VCC and PGND. Nothing else should be connected to power ground.

VREF should be bypassed directly to the signal portion of the ground plane with a good high frequency capacitor. Low ESR/ESL ceramic 1-mF capacitors are recommended for both VCC and VREF. All analog circuitry should likewise be bypassed to the signal ground plane.

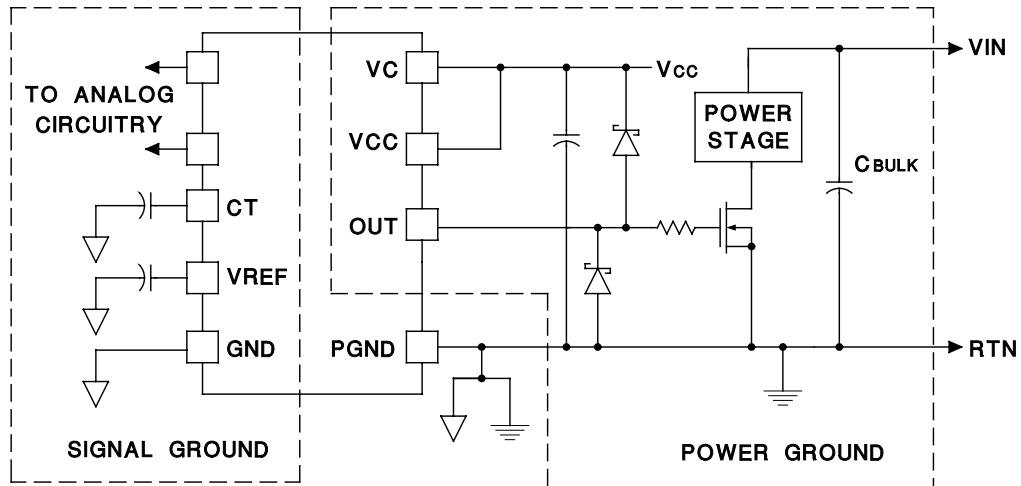

UDG-95115

Figure 13. Ground Planes Diagram

### OPEN LOOP TEST CIRCUIT

This test fixture is useful for exercising many functions of this device family and measuring their specifications. As with any wideband circuit, careful grounding and bypass procedures should be followed. The use of a ground plane is highly recommended.

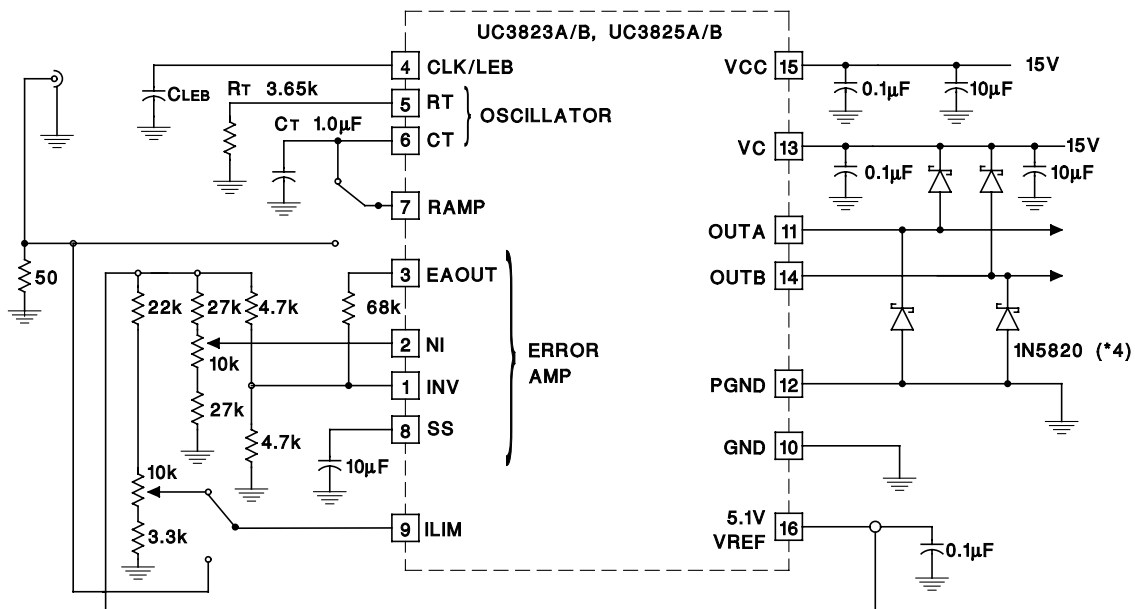

UDG-95116

Figure 14. Open Loop Test Circuit Schematic

**PACKAGING INFORMATION**

Orderable Device	Status <sup>(1)</sup>	Package Type	Package Drawing	Pins	Package Qty	Eco Plan <sup>(2)</sup>	Lead/Ball Finish	MSL Peak Temp <sup>(3)</sup>
5962-87681022A	ACTIVE	LCCC	FK	20	1	TBD	POST-PLATE	N / A for Pkg Type
5962-8768102EA	ACTIVE	CDIP	J	16	1	TBD	A42 SNPB	N / A for Pkg Type
5962-8768102V2A	ACTIVE	LCCC	FK	20	1	TBD	Call TI	N / A for Pkg Type
5962-8768102VEA	ACTIVE	CDIP	J	16	1	TBD	Call TI	N / A for Pkg Type
5962-8768102XA	OBSOLETE	TO-92	LP	28		TBD	Call TI	N / A for Pkg Type
5962-8768103XA	OBSOLETE	TO-92	LP	28		TBD	Call TI	N / A for Pkg Type
5962-89905022A	ACTIVE	LCCC	FK	20	1	TBD	POST-PLATE	N / A for Pkg Type
5962-8990502EA	ACTIVE	CDIP	J	16	1	TBD	A42 SNPB	N / A for Pkg Type
5962-8990502VEA	ACTIVE	CDIP	J	16	1	TBD	Call TI	N / A for Pkg Type
UC1823AJ	ACTIVE	CDIP	J	16	1	TBD	A42 SNPB	N / A for Pkg Type
UC1823AJ883B	ACTIVE	CDIP	J	16	1	TBD	A42 SNPB	N / A for Pkg Type
UC1823AJQMLV	ACTIVE	CDIP	J	16		TBD	Call TI	Call TI
UC1823AL	ACTIVE	LCCC	FK	20	1	TBD	POST-PLATE	N / A for Pkg Type
UC1823AL883B	ACTIVE	LCCC	FK	20	1	TBD	POST-PLATE	N / A for Pkg Type
UC1823BJ	OBSOLETE	CDIP	J	16		TBD	Call TI	Call TI
UC1823BJ883B	OBSOLETE	CDIP	J	16		TBD	Call TI	Call TI
UC1823BL	OBSOLETE	LCCC	FK	20		TBD	Call TI	Call TI
UC1823BL883B	OBSOLETE	LCCC	FK	20		TBD	Call TI	Call TI
UC1825AJ	ACTIVE	CDIP	J	16	1	TBD	A42 SNPB	N / A for Pkg Type
UC1825AJ883B	ACTIVE	CDIP	J	16	1	TBD	A42 SNPB	N / A for Pkg Type
UC1825AJQMLV	ACTIVE	CDIP	J	16		TBD	Call TI	Call TI
UC1825AL	ACTIVE	LCCC	FK	20	1	TBD	POST-PLATE	N / A for Pkg Type
UC1825AL883B	ACTIVE	LCCC	FK	20	1	TBD	POST-PLATE	N / A for Pkg Type
UC1825ALP883B	OBSOLETE	TO-92	LP	28		TBD	Call TI	N / A for Pkg Type
UC1825ALQMLV	ACTIVE	LCCC	FK	20		TBD	Call TI	Call TI
UC1825BJ	OBSOLETE	CDIP	J	16		TBD	Call TI	Call TI
UC1825BJ883B	OBSOLETE	CDIP	J	16		TBD	Call TI	Call TI
UC1825BL/81047	OBSOLETE	TO/SOT	L	20		TBD	Call TI	Call TI
UC1825BL883B	OBSOLETE	LCCC	FK	20		TBD	Call TI	Call TI
UC1825BLP883B	OBSOLETE	TO-92	LP	28		TBD	Call TI	N / A for Pkg Type
UC2823ADW	ACTIVE	SOIC	DW	16	40	Green (RoHS & no Sb/Br)	CU NIPDAU	Level-2-260C-1 YEAR
UC2823ADWG4	ACTIVE	SOIC	DW	16	40	Green (RoHS & no Sb/Br)	CU NIPDAU	Level-2-260C-1 YEAR
UC2823ADWTR	ACTIVE	SOIC	DW	16	2000	Green (RoHS & no Sb/Br)	CU NIPDAU	Level-2-260C-1 YEAR
UC2823ADWTRG4	ACTIVE	SOIC	DW	16	2000	Green (RoHS & no Sb/Br)	CU NIPDAU	Level-2-260C-1 YEAR
UC2823AN	ACTIVE	PDIP	N	16	25	Green (RoHS & no Sb/Br)	CU NIPDAU	N / A for Pkg Type
UC2823ANG4	ACTIVE	PDIP	N	16	25	Green (RoHS & no Sb/Br)	CU NIPDAU	N / A for Pkg Type
UC2823AQ	ACTIVE	PLCC	FN	20	46	Green (RoHS & no Sb/Br)	CU SN	Level-2-260C-1 YEAR

Orderable Device	Status <sup>(1)</sup>	Package Type	Package Drawing	Pins	Package Qty	Eco Plan <sup>(2)</sup>	Lead/Ball Finish	MSL Peak Temp <sup>(3)</sup>
UC2823BDW	ACTIVE	SOIC	DW	16	40	Green (RoHS & no Sb/Br)	CU NIPDAU	Level-2-260C-1 YEAR
UC2823BDWG4	ACTIVE	SOIC	DW	16	40	Green (RoHS & no Sb/Br)	CU NIPDAU	Level-2-260C-1 YEAR
UC2823BJ	OBSOLETE	CDIP	J	16		TBD	Call TI	Call TI
UC2823BN	ACTIVE	PDIP	N	16	25	Green (RoHS & no Sb/Br)	CU NIPDAU	N / A for Pkg Type
UC2823BNG4	ACTIVE	PDIP	N	16	25	Green (RoHS & no Sb/Br)	CU NIPDAU	N / A for Pkg Type
UC2825ADW	ACTIVE	SOIC	DW	16	40	Green (RoHS & no Sb/Br)	CU NIPDAU	Level-2-260C-1 YEAR
UC2825ADWG4	ACTIVE	SOIC	DW	16	40	Green (RoHS & no Sb/Br)	CU NIPDAU	Level-2-260C-1 YEAR
UC2825ADWTR	ACTIVE	SOIC	DW	16	2000	Green (RoHS & no Sb/Br)	CU NIPDAU	Level-2-260C-1 YEAR
UC2825ADWTRG4	ACTIVE	SOIC	DW	16	2000	Green (RoHS & no Sb/Br)	CU NIPDAU	Level-2-260C-1 YEAR
UC2825AN	ACTIVE	PDIP	N	16	25	Green (RoHS & no Sb/Br)	CU NIPDAU	N / A for Pkg Type
UC2825ANG4	ACTIVE	PDIP	N	16	25	Green (RoHS & no Sb/Br)	CU NIPDAU	N / A for Pkg Type
UC2825AQ	ACTIVE	PLCC	FN	20	46	Green (RoHS & no Sb/Br)	CU SN	Level-2-260C-1 YEAR
UC2825AQG3	ACTIVE	PLCC	FN	20	46	Green (RoHS & no Sb/Br)	CU SN	Level-2-260C-1 YEAR
UC2825BDW	ACTIVE	SOIC	DW	16	40	Green (RoHS & no Sb/Br)	CU NIPDAU	Level-2-260C-1 YEAR
UC2825BDWG4	ACTIVE	SOIC	DW	16	40	Green (RoHS & no Sb/Br)	CU NIPDAU	Level-2-260C-1 YEAR
UC2825BDWTRG4	ACTIVE	SOIC	DW	16		TBD	Call TI	Call TI
UC2825BJ	OBSOLETE	CDIP	J	16		TBD	Call TI	Call TI
UC2825BN	ACTIVE	PDIP	N	16	25	Green (RoHS & no Sb/Br)	CU NIPDAU	N / A for Pkg Type
UC2825BNG4	ACTIVE	PDIP	N	16	25	Green (RoHS & no Sb/Br)	CU NIPDAU	N / A for Pkg Type
UC3823ADW	ACTIVE	SOIC	DW	16	40	Green (RoHS & no Sb/Br)	CU NIPDAU	Level-2-260C-1 YEAR
UC3823ADWG4	ACTIVE	SOIC	DW	16	40	Green (RoHS & no Sb/Br)	CU NIPDAU	Level-2-260C-1 YEAR
UC3823ADWTR	ACTIVE	SOIC	DW	16	2000	Green (RoHS & no Sb/Br)	CU NIPDAU	Level-2-260C-1 YEAR
UC3823ADWTRG4	ACTIVE	SOIC	DW	16	2000	Green (RoHS & no Sb/Br)	CU NIPDAU	Level-2-260C-1 YEAR
UC3823AN	ACTIVE	PDIP	N	16	25	Green (RoHS & no Sb/Br)	CU NIPDAU	N / A for Pkg Type
UC3823ANG4	ACTIVE	PDIP	N	16	25	Green (RoHS & no Sb/Br)	CU NIPDAU	N / A for Pkg Type
UC3823BDW	ACTIVE	SOIC	DW	16	40	Green (RoHS & no Sb/Br)	CU NIPDAU	Level-2-260C-1 YEAR
UC3823BDWG4	ACTIVE	SOIC	DW	16	40	Green (RoHS & no Sb/Br)	CU NIPDAU	Level-2-260C-1 YEAR

Orderable Device	Status <sup>(1)</sup>	Package Type	Package Drawing	Pins	Package Qty	Eco Plan <sup>(2)</sup>	Lead/Ball Finish	MSL Peak Temp <sup>(3)</sup>
UC3823BDWTR	ACTIVE	SOIC	DW	16	2000	Green (RoHS & no Sb/Br)	CU NIPDAU	Level-2-260C-1 YEAR
UC3823BDWTRG4	ACTIVE	SOIC	DW	16	2000	Green (RoHS & no Sb/Br)	CU NIPDAU	Level-2-260C-1 YEAR
UC3823BN	ACTIVE	PDIP	N	16	25	Green (RoHS & no Sb/Br)	CU NIPDAU	N / A for Pkg Type
UC3823BNG4	ACTIVE	PDIP	N	16	25	Green (RoHS & no Sb/Br)	CU NIPDAU	N / A for Pkg Type
UC3825ADW	ACTIVE	SOIC	DW	16	40	Green (RoHS & no Sb/Br)	CU NIPDAU	Level-2-260C-1 YEAR
UC3825ADWG4	ACTIVE	SOIC	DW	16	40	Green (RoHS & no Sb/Br)	CU NIPDAU	Level-2-260C-1 YEAR
UC3825ADWTR	ACTIVE	SOIC	DW	16	2000	Green (RoHS & no Sb/Br)	CU NIPDAU	Level-2-260C-1 YEAR
UC3825ADWTRG4	ACTIVE	SOIC	DW	16	2000	Green (RoHS & no Sb/Br)	CU NIPDAU	Level-2-260C-1 YEAR
UC3825AN	ACTIVE	PDIP	N	16	25	Green (RoHS & no Sb/Br)	CU NIPDAU	N / A for Pkg Type
UC3825ANG4	ACTIVE	PDIP	N	16	25	Green (RoHS & no Sb/Br)	CU NIPDAU	N / A for Pkg Type
UC3825AQ	ACTIVE	PLCC	FN	20	46	Green (RoHS & no Sb/Br)	CU SN	Level-2-260C-1 YEAR
UC3825AQG3	ACTIVE	PLCC	FN	20	46	Green (RoHS & no Sb/Br)	CU SN	Level-2-260C-1 YEAR
UC3825AQTRG3	ACTIVE	PLCC	FN	20		TBD	Call TI	Call TI
UC3825BDW	ACTIVE	SOIC	DW	16	40	Green (RoHS & no Sb/Br)	CU NIPDAU	Level-2-260C-1 YEAR
UC3825BDWG4	ACTIVE	SOIC	DW	16	40	Green (RoHS & no Sb/Br)	CU NIPDAU	Level-2-260C-1 YEAR
UC3825BDWTR	ACTIVE	SOIC	DW	16	2000	Green (RoHS & no Sb/Br)	CU NIPDAU	Level-2-260C-1 YEAR
UC3825BDWTRG4	ACTIVE	SOIC	DW	16	2000	Green (RoHS & no Sb/Br)	CU NIPDAU	Level-2-260C-1 YEAR
UC3825BN	ACTIVE	PDIP	N	16	25	Green (RoHS & no Sb/Br)	CU NIPDAU	N / A for Pkg Type
UC3825BNG4	ACTIVE	PDIP	N	16	25	Green (RoHS & no Sb/Br)	CU NIPDAU	N / A for Pkg Type

<sup>(1)</sup> The marketing status values are defined as follows:

**ACTIVE:** Product device recommended for new designs.

**LIFEBUY:** TI has announced that the device will be discontinued, and a lifetime-buy period is in effect.

**NRND:** Not recommended for new designs. Device is in production to support existing customers, but TI does not recommend using this part in a new design.

**PREVIEW:** Device has been announced but is not in production. Samples may or may not be available.

**OBSOLETE:** TI has discontinued the production of the device.

<sup>(2)</sup> Eco Plan - The planned eco-friendly classification: Pb-Free (RoHS), Pb-Free (RoHS Exempt), or Green (RoHS & no Sb/Br) - please check <http://www.ti.com/productcontent> for the latest availability information and additional product content details.

**TBD:** The Pb-Free/Green conversion plan has not been defined.

**Pb-Free (RoHS):** TI's terms "Lead-Free" or "Pb-Free" mean semiconductor products that are compatible with the current RoHS requirements for all 6 substances, including the requirement that lead not exceed 0.1% by weight in homogeneous materials. Where designed to be soldered at high temperatures, TI Pb-Free products are suitable for use in specified lead-free processes.

**Pb-Free (RoHS Exempt):** This component has a RoHS exemption for either 1) lead-based flip-chip solder bumps used between the die and package, or 2) lead-based die adhesive used between the die and leadframe. The component is otherwise considered Pb-Free (RoHS

compatible) as defined above.

**Green (RoHS & no Sb/Br):** TI defines "Green" to mean Pb-Free (RoHS compatible), and free of Bromine (Br) and Antimony (Sb) based flame retardants (Br or Sb do not exceed 0.1% by weight in homogeneous material)

<sup>(3)</sup> MSL, Peak Temp. -- The Moisture Sensitivity Level rating according to the JEDEC industry standard classifications, and peak solder temperature.

**Important Information and Disclaimer:**The information provided on this page represents TI's knowledge and belief as of the date that it is provided. TI bases its knowledge and belief on information provided by third parties, and makes no representation or warranty as to the accuracy of such information. Efforts are underway to better integrate information from third parties. TI has taken and continues to take reasonable steps to provide representative and accurate information but may not have conducted destructive testing or chemical analysis on incoming materials and chemicals. TI and TI suppliers consider certain information to be proprietary, and thus CAS numbers and other limited information may not be available for release.

In no event shall TI's liability arising out of such information exceed the total purchase price of the TI part(s) at issue in this document sold by TI to Customer on an annual basis.





Carrier tape design is defined largely by the component length, width, and thickness.

$A_o$ = Dimension designed to accommodate the component width.
$B_o$ = Dimension designed to accommodate the component length.
$K_o$ = Dimension designed to accommodate the component thickness.
$W$ = Overall width of the carrier tape.
$P$ = Pitch between successive cavity centers.



**TAPE AND REEL INFORMATION**

Device	Package	Pins	Site	Reel Diameter (mm)	Reel Width (mm)	A0 (mm)	B0 (mm)	K0 (mm)	P1 (mm)	W (mm)	Pin1 Quadrant
UC2823ADWTR	DW	16	MLA	330	16	10.85	10.8	2.7	12	16	Q1
UC2825ADWTR	DW	16	MLA	330	16	10.85	10.8	2.7	12	16	Q1
UC3823ADWTR	DW	16	MLA	330	16	10.85	10.8	2.7	12	16	Q1
UC3823BDWTR	DW	16	MLA	330	16	10.85	10.8	2.7	12	16	Q1
UC3825ADWTR	DW	16	MLA	330	16	10.85	10.8	2.7	12	16	Q1
UC3825BDWTR	DW	16	MLA	330	16	10.85	10.8	2.7	12	16	Q1

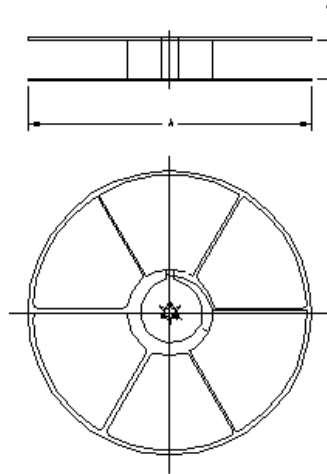

**TAPE AND REEL BOX INFORMATION**

Device	Package	Pins	Site	Length (mm)	Width (mm)	Height (mm)
UC2823ADWTR	DW	16	MLA	0.0	0.0	0.0
UC2825ADWTR	DW	16	MLA	0.0	0.0	0.0
UC3823ADWTR	DW	16	MLA	0.0	0.0	0.0
UC3823BDWTR	DW	16	MLA	0.0	0.0	0.0
UC3825ADWTR	DW	16	MLA	0.0	0.0	0.0
UC3825BDWTR	DW	16	MLA	0.0	0.0	0.0

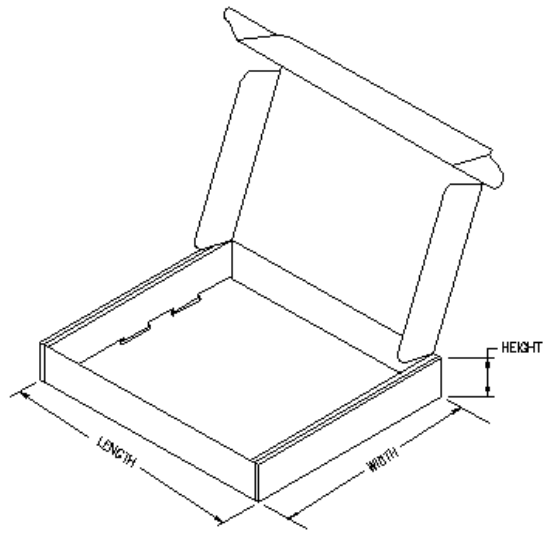

## IMPORTANT NOTICE

Texas Instruments Incorporated and its subsidiaries (TI) reserve the right to make corrections, modifications, enhancements, improvements, and other changes to its products and services at any time and to discontinue any product or service without notice. Customers should obtain the latest relevant information before placing orders and should verify that such information is current and complete. All products are sold subject to TI's terms and conditions of sale supplied at the time of order acknowledgment.

TI warrants performance of its hardware products to the specifications applicable at the time of sale in accordance with TI's standard warranty. Testing and other quality control techniques are used to the extent TI deems necessary to support this warranty. Except where mandated by government requirements, testing of all parameters of each product is not necessarily performed.

TI assumes no liability for applications assistance or customer product design. Customers are responsible for their products and applications using TI components. To minimize the risks associated with customer products and applications, customers should provide adequate design and operating safeguards.

TI does not warrant or represent that any license, either express or implied, is granted under any TI patent right, copyright, mask work right, or other TI intellectual property right relating to any combination, machine, or process in which TI products or services are used. Information published by TI regarding third-party products or services does not constitute a license from TI to use such products or services or a warranty or endorsement thereof. Use of such information may require a license from a third party under the patents or other intellectual property of the third party, or a license from TI under the patents or other intellectual property of TI.

Reproduction of TI information in TI data books or data sheets is permissible only if reproduction is without alteration and is accompanied by all associated warranties, conditions, limitations, and notices. Reproduction of this information with alteration is an unfair and deceptive business practice. TI is not responsible or liable for such altered documentation. Information of third parties may be subject to additional restrictions.

Resale of TI products or services with statements different from or beyond the parameters stated by TI for that product or service voids all express and any implied warranties for the associated TI product or service and is an unfair and deceptive business practice. TI is not responsible or liable for any such statements.

TI products are not authorized for use in safety-critical applications (such as life support) where a failure of the TI product would reasonably be expected to cause severe personal injury or death, unless officers of the parties have executed an agreement specifically governing such use. Buyers represent that they have all necessary expertise in the safety and regulatory ramifications of their applications, and acknowledge and agree that they are solely responsible for all legal, regulatory and safety-related requirements concerning their products and any use of TI products in such safety-critical applications, notwithstanding any applications-related information or support that may be provided by TI. Further, Buyers must fully indemnify TI and its representatives against any damages arising out of the use of TI products in such safety-critical applications.

TI products are neither designed nor intended for use in military/aerospace applications or environments unless the TI products are specifically designated by TI as military-grade or "enhanced plastic." Only products designated by TI as military-grade meet military specifications. Buyers acknowledge and agree that any such use of TI products which TI has not designated as military-grade is solely at the Buyer's risk, and that they are solely responsible for compliance with all legal and regulatory requirements in connection with such use.

TI products are neither designed nor intended for use in automotive applications or environments unless the specific TI products are designated by TI as compliant with ISO/TS 16949 requirements. Buyers acknowledge and agree that, if they use any non-designated products in automotive applications, TI will not be responsible for any failure to meet such requirements.

Following are URLs where you can obtain information on other Texas Instruments products and application solutions:

<b>Products</b>		<b>Applications</b>	
Amplifiers	<a href="http://amplifier.ti.com">amplifier.ti.com</a>	Audio	<a href="http://www.ti.com/audio">www.ti.com/audio</a>
Data Converters	<a href="http://dataconverter.ti.com">dataconverter.ti.com</a>	Automotive	<a href="http://www.ti.com/automotive">www.ti.com/automotive</a>
DSP	<a href="http://dsp.ti.com">dsp.ti.com</a>	Broadband	<a href="http://www.ti.com/broadband">www.ti.com/broadband</a>
Interface	<a href="http://interface.ti.com">interface.ti.com</a>	Digital Control	<a href="http://www.ti.com/digitalcontrol">www.ti.com/digitalcontrol</a>
Logic	<a href="http://logic.ti.com">logic.ti.com</a>	Military	<a href="http://www.ti.com/military">www.ti.com/military</a>
Power Mgmt	<a href="http://power.ti.com">power.ti.com</a>	Optical Networking	<a href="http://www.ti.com/opticalnetwork">www.ti.com/opticalnetwork</a>
Microcontrollers	<a href="http://microcontroller.ti.com">microcontroller.ti.com</a>	Security	<a href="http://www.ti.com/security">www.ti.com/security</a>
RFID	<a href="http://www.ti-rfid.com">www.ti-rfid.com</a>	Telephony	<a href="http://www.ti.com/telephony">www.ti.com/telephony</a>
Low Power Wireless	<a href="http://www.ti.com/lpw">www.ti.com/lpw</a>	Video & Imaging	<a href="http://www.ti.com/video">www.ti.com/video</a>
		Wireless	<a href="http://www.ti.com/wireless">www.ti.com/wireless</a>

Mailing Address: Texas Instruments, Post Office Box 655303, Dallas, Texas 75265  
Copyright © 2007, Texas Instruments Incorporated