

Large Current External FET Controller T type Switching Regulators



# Dual-output Step-up, Negative Voltage, Step-down Switching Regulators (Controller type)

**BA9743AFV, BA9744FV, BA9741F, BA9741FS**

No.11028EBT10

## ● Description

The BA9743AFV, BA9744FV, and BA9741F/FS are a 2-channel ICs, incorporating a switching regulator controller that uses a pulse width modulation. Both channels can be used for DC/DC converter operations including step up, step down, and inverting. Furthermore, since these ICs have significantly compact design, they are best suited for use as a power supply in miniature portable equipment.

## ● Features

- 1) Built-in timer-latch type short prevention circuit
- 2) Built-in malfunction prevention circuit during low input voltage
- 3) Built-in high-accuracy reference voltage output pin
 

BA9743AFV	2.505V±1%
BA9744FV	1.222V±1%
BA9741F/FS	2.5V±4%
- 4) Rest period adjustable over the whole range of duty ratio
- 5) A wide input range provided
 

BA9741F	VCC=3.6 to 35V
BA9741FS	VCC=3.6 to 35V
BA9743AFV	VCC=3.6 to 35V
BA9744FV	VCC=2.5 to 35V

## ● Applications

DC/DC converter in LCD, PC, AV, printer, DVD, projector, TV, Fax machine, Copying machine, Measuring equipment, etc

## ● Product lineup

	BA9743AFV	BA9744FV	BA9741F/FS
Power supply voltage	3.6V~35V	3.6V~35V	3.6V~35V
Output pin current	100mA	30mA	100mA
Output pin voltage	Max. 35V	Max. 35V	Max. 35V
Error amplifier input voltage	0.3V~1.6V	0.3V~1.5V	0.3V~1.6V
Timing capacitance	100p~15000pF	100p~15000pF	100p~15000pF
Timing resistance	5.1k~50kΩ	3k~15kΩ	5.1k~50kΩ
Oscillation frequency	10k~800kHz	10k~800kHz	10k~800kHz
Operating temperature	-40°C~+85°C	-40°C~+85°C	-40°C~+85°C
Package	SSOP-B16	SSOP-B16	SOP16/SSOP-A16

● Absolute maximum ratings

Item	Symbol	Limits				Unit
		BA9743AFV	BA9744FV	BA9741F	BA9741FS	
Power supply voltage	VCC	36	36	36		V
Power dissipation	Pd	450 <sup>*3</sup>	450 <sup>*3</sup>	500 <sup>*1</sup>	650 <sup>*2</sup>	mW
Operating temperature	Topr	-40~+85	-40~+85	-40~+85		°C
Storage temperature	Tstg	-55~+125	-55~+125	-55~+125		°C
Output pin current	Io	120 <sup>*4</sup>	60 <sup>*4</sup>	120 <sup>*4</sup>		mA
Output pin voltage	Vo	36	36	36		V

\*1 Reduce by 4.5 mW/ °C over 25°C.  
(when mounted on a PCB of 50mm×50mm×1.6 mm)

\*2 Reduce by 5.0 mW/ °C over 25°C.  
(when mounted on a PCB of 70mm×70mm×1.6 mm)

\*3 Reduce by 6.5 mW/ °C over 25°C.  
(when mounted on a PCB of 70mm×70mm×1.6 mm)

\*4 Should not exceed Pd- or ASO-value.

● Electrical characteristics

◎ BA9743AFV

Electrical characteristics (Unless otherwise specified, Ta=25°C and Vcc=6V)

Item	Symbol	Limits			Unit	Conditions
		Min.	Typ.	Max.		
[Reference voltage section]						
Output voltage	VREF	2.48	2.505	2.53	V	IREF=1mA
Input stability	VdLI	—	1	10	mV	VCC=3.6~35V
Load stability	VdLO	—	1	10	mV	IREF=0~5mA
[Triangular wave oscillator section]						
Oscillation frequency	FOSC	320	400	480	KHz	RRT=10kΩ, CCT=220pF
Frequency variation	FDV	—	1	—	%	VCC=3.6~35V
[Protection circuit section]						
Threshold voltage	VIT	1.48	1.64	1.80	V	
Standby voltage	VSTB	—	50	100	mV	No pull-up
Latch voltage	VLT	—	30	100	mV	No pull-up
Source current	ISCP	1.5	2.5	3.5	μA	
Comparator threshold voltage	VCT	0.95	1.05	1.15	V	5pin, 12pin
[Rest period adjustment circuit section]						
Input threshold voltage (fosc=10kHz)	Vt0	1.87	1.97	2.07	V	Duty cycle = 0%
	Vt100	1.38	1.48	1.58	V	Duty cycle = 100%
ON duty cycle	DON	45	55	65	%	VREF is divided by 13kΩ and 27kΩ resistors.
Input bias current	IBDT	—	0.1	1	μA	DTC=2.0V
Latch mode source current	IDT	200	560	—	μA	DTC=0V
Latch input voltage	VDT	2.28	2.48	—	V	IDT=40 μA
[Low-input-voltage malfunction prevention circuit section]						
Threshold voltage	VUT	2.23	2.53	2.83	V	
[Error amplifier section]						
Input offset voltage	VIO	—	—	6	mV	
Input offset current	IIO	—	—	30	nA	
Input bias current	IIB	—	15	100	nA	
Open loop gain	AV	70	85	—	dB	
Common-mode input voltage	VCM	0.3	—	1.6	V	VCC=3.6~35V
Common-mode rejection ratio	CMRR	60	80	—	dB	
Maximum output voltage	VOM	2.3	2.5	—	V	
Minimum output current	VOL	—	0.7	0.9	V	
Output sink current	IOI	3	20	—	mA	FB=1.25V
Output source current	IOO	45	75	—	μA	FB=1.25V
[PWM comparator section]						
Input threshold voltage (fosc=10kHz)	Vt0	1.87	1.97	2.07	V	Duty cycle = 0%
	Vt100	1.38	1.48	1.58	V	Duty cycle = 100%
[Output section]						
Saturation voltage	VSAT	—	0.8	1.2	V	Io=75mA
Leak current	I LEAK	—	—	5	μA	Vo=35V
[Total device]						
Standby current	ICCS	—	1.3	1.8	mA	When output is OFF
Average current dissipation	ICCA	—	1.6	2.3	mA	RRT=10kΩ

◎ This IC is not designed to be radiation-resistant.

## ◎BA9744FV

Electrical characteristics (Unless otherwise specified, Ta=25°C and Vcc=3V)

Item	Symbol	Limits			Unit	Conditions
		Min.	Typ.	Max.		
[Reference voltage section]						
Output voltage	VREF	1.210	1.222	1.234	V	IREF=1mA
Input stability	VDLI	—	3	10	mV	VCC=2.5~35V
Load stability	VULO	—	1	10	mV	IREF=0~5mA
[Triangular wave oscillator section]						
Oscillation frequency	FOSC	320	400	480	KHz	RRT=5.1k,CCT=220pF
Frequency variation	F <sub>OV</sub>	—	1	—	%	Vcc=2.5~35V
[Protection circuit section]						
Threshold voltage	V <sub>IT</sub>	0.98	1.18	1.38	V	
Standby voltage	V <sub>STB</sub>	—	50	100	mV	No pull-up
Latch voltage	V <sub>LT</sub>	—	23	100	mV	No pull-up
Source current	I <sub>SCP</sub>	1.0	2.0	3.0	μA	
Comparator threshold voltage	V <sub>CT</sub>	0.15	0.25	0.35	V	5pin, 12pin
[Rest period adjustment circuit section]						
Input threshold voltage (fosc=10kHz)	V <sub>t0</sub>	0.96	1.01	1.06	V	Duty cycle=0%
	V <sub>t100</sub>	0.46	0.49	0.52	V	Duty cycle=100%
ON duty cycle	D <sub>ON</sub>	45	55	65	%	
Input bias current	I <sub>BDT</sub>	—	0.1	1	μA	DTC=2V
Latch mode source current	I <sub>DT</sub>	390	780	—	μA	DTC=0V
Latch input voltage	V <sub>DT</sub>	Vcc-0.5	Vcc-0.4	—	V	IDT=40μA
[Low-input-voltage malfunction prevention circuit section]						
Threshold voltage	V <sub>UT</sub>	1.6	1.9	2.2	V	
[Error amplifier section]						
Input offset voltage	V <sub>I0</sub>	—	0	6	mV	
Input offset current	I <sub>I0</sub>	—	0	30	nA	
Input bias current	I <sub>IB</sub>	—	15	100	nA	
Open loop gain	A <sub>V</sub>	65	85	—	dB	
Common-mode input voltage	V <sub>CM</sub>	0.3	—	1.5	V	VCC=2.5~35V
Common-mode rejection ratio	CMRR	60	80	—	dB	
Maximum output voltage	V <sub>OM</sub>	1.5	2.0	—	V	
Minimum output current	V <sub>OL</sub>	—	0.1	0.3	V	
Output sink current	I <sub>O1</sub>	1	2.1	—	mA	FB=0.75V
Output source current	I <sub>O0</sub>	50	70	90	μA	FB=0.75V
[PWM comparator section]						
Input threshold voltage (fosc=10kHz)	V <sub>t0</sub>	0.96	1.01	1.06	V	Duty cycle=0%
	V <sub>t100</sub>	0.46	0.49	0.52	V	Duty cycle=100%
[Output section]						
Saturation voltage 1	V <sub>SAT</sub>	—	0.06	0.3	V	I <sub>o</sub> =10mA
Saturation voltage 2	V <sub>SAT</sub>	—	0.15	0.4	V	I <sub>o</sub> =30mA
Leak current	I <sub>LEAK</sub>	—	0	5	μA	V <sub>o</sub> =35V
[Total device]						
Standby current	I <sub>CCS</sub>	—	3.6	5.0	mA	When output is OFF
Average current dissipation	I <sub>CCA</sub>	—	3.9	5.6	mA	RRT=5.1kΩ

◎ This IC is not designed to be radiation-resistant.

## ◎BA9741F/BA9741FS

Electrical characteristics (Unless otherwise specified, Ta=25°C and Vcc=3V)

Item	Symbol	Limits			Unit	Conditions
		Min.	Typ.	Max.		
[Reference voltage section]						
Output voltage	VREF	2.4	2.5	2.6	V	IREF=1mA
Input stability	VDLI	—	1	10	mV	VCC=3.6~35V
Load stability	VDLO	—	1	10	mV	IREF=0~5mA
[Triangular wave oscillator section]						
Oscillation frequency	FOSC	320	400	480	KHz	RRT=10kΩ,CCT=220pF
Frequency variation	Fdv	—	1	—	%	VCC=3.6~35V
[Protection circuit section]						
Threshold voltage	VIT	1.48	1.64	1.80	V	
Standby voltage	VSTB	—	50	100	mV	No pull-up
Latch voltage	VLT	—	30	100	mV	No pull-up
Source current	ISCP	1.5	2.5	3.5	μA	
Comparator threshold voltage	VCT	0.9	1.05	1.2	V	5pin, 12pin
[Rest period adjustment circuit section]						
Input threshold voltage (fosc=10kHz)	Vt0	1.79	1.97	2.15	V	Duty cycle=0%
	Vt100	1.32	1.48	1.64	V	Duty cycle=100%
ON duty cycle	DON	45	55	65	%	VREF is divided by 13kΩ and 27kΩ resistors.
Input bias current	IBDT	—	0.1	1	μA	DTC=2.0V
Latch mode source current	IDT	200	560	—	μA	DTC=0V
Latch input voltage	VDT	2.28	2.48	—	V	IDT=40 μA
[Low-input-voltage malfunction prevention circuit section]						
Threshold voltage	VUT	—	2.53	—	V	
[Error amplifier section]						
Input offset voltage	VIO	—	—	6	mV	
Input offset current	IIO	—	—	30	nA	
Input bias current	IIB	—	15	100	nA	
Open loop gain	AV	70	85	—	dB	
Common-mode input voltage	VCM	0.3	—	1.6	V	VCC=3.6~35V
Common-mode rejection ratio	CMRR	60	80	—	dB	
Maximum output voltage	VOM	2.3	2.5	—	V	
Minimum output current	VOL	—	0.7	0.9	V	
Output sink current	I01	3	20	—	mA	FB=1.25V
Output source current	I00	45	75	—	μA	FB=1.25V
[PWM comparator section]						
Input threshold voltage (fosc=10kHz)	Vt0	1.79	1.97	2.15	V	Duty cycle=0%
	Vt100	1.32	1.48	1.64	V	Duty cycle=100%
[Output section]						
Saturation voltage	VSAT	—	0.8	1.2	V	Io=75mA
Leak current	I <sub>LEAK</sub>	—	—	5	μA	Vo=35V
[Total device]						
Standby current	ICCS	—	1.3	1.8	mA	When output is OFF
Average current dissipation	ICCA	—	1.6	2.3	mA	RRT=10kΩ

◎ This IC is not designed to be radiation-resistant.

● Reference data

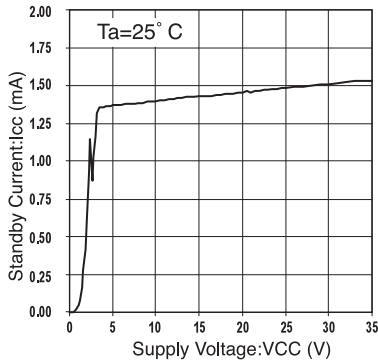

Fig. 1 Standby current vs. Power supply voltage (BA9741F/FS/BA9743AFV)

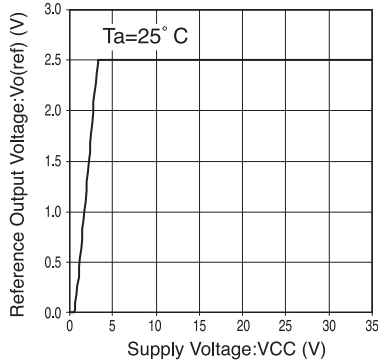

Fig. 2 Reference output voltage vs. Power supply voltage (BA9741F/FS/BA9743AFV)

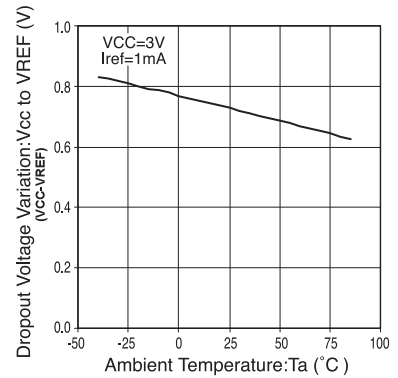

Fig. 3 Dropout voltage vs. Ambient temperature (BA9741F/FS/BA9743AFV)

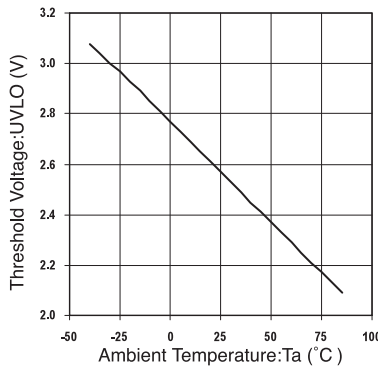

Fig. 4 UVLO operating voltage vs. Ambient temperature (BA9741F/FS/BA9743AFV)

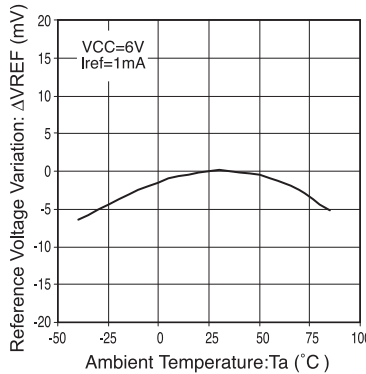

Fig. 5 Reference voltage vs. Ambient temperature (BA9741F/FS/BA9743AFV)

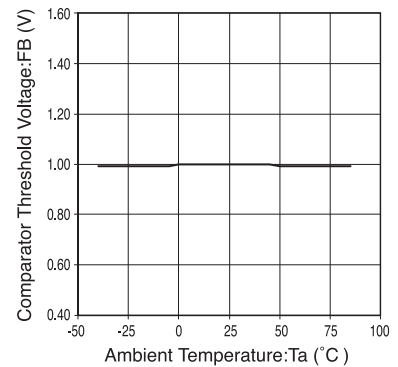

Fig. 6 Protection circuit characteristics (BA9741F/FS/BA9743AFV)

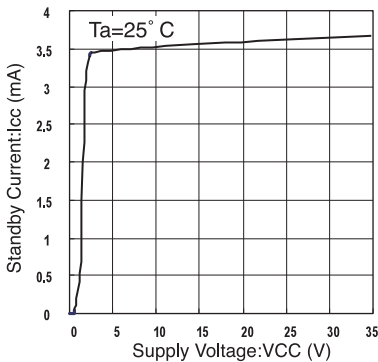

Fig. 7 Standby current vs. Power supply voltage (BA9744FV)

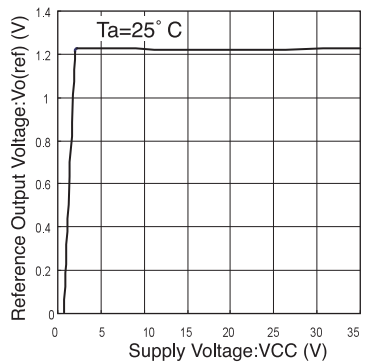

Fig. 8 Reference output voltage vs. Power supply voltage (BA9744FV)

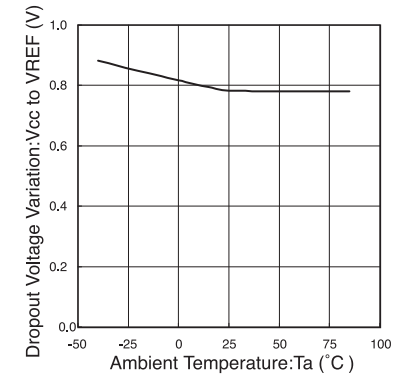

Fig. 9 Dropout voltage vs. Ambient temperature (BA9744FV)

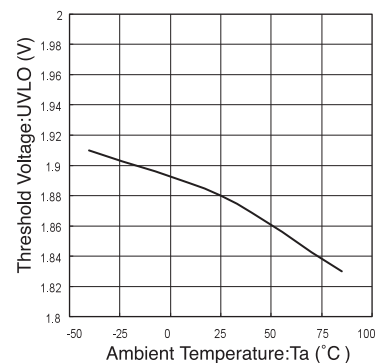

Fig. 10 UVLO operating voltage vs. Ambient temperature (BA9744FV)

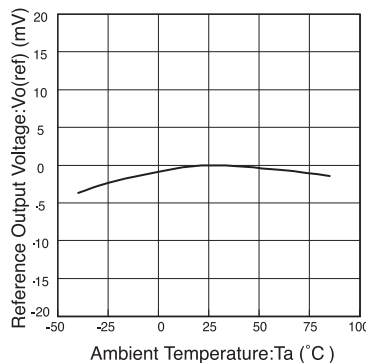

Fig. 11 Reference voltage vs. Ambient temperature (BA9744FV)

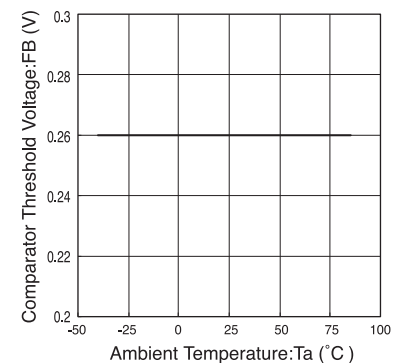

Fig. 12 Protection circuit characteristics (BA9744FV)

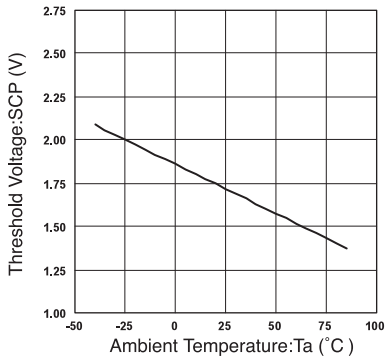

Fig. 13 Protection circuit characteristics (BA9741F/FS/BA9743AFV)

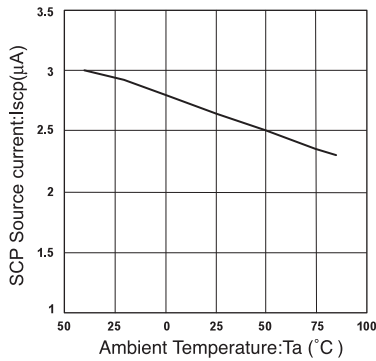

Fig. 14 Protection circuit characteristics (BA9741F/FS/BA9743AFV)

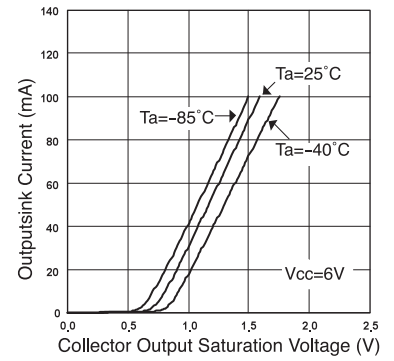

Fig. 15 Output current vs. Collector saturation voltage (BA9741F/FS/BA9743AFV)

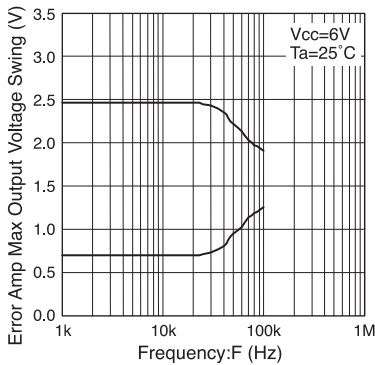

Fig. 16 Error amp. Output voltage vs. Amplitude frequency (BA9741F/FS/BA9743AFV)

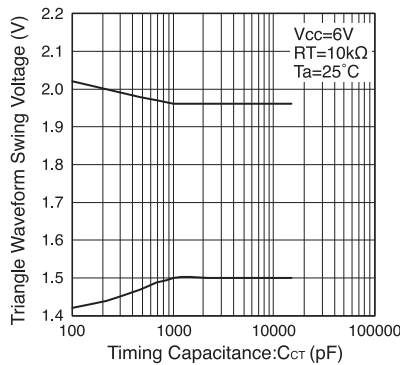

Fig. 17 Triangular wave amplitude vs. Timing capacitor (BA9741F/FS/BA9743AFV)

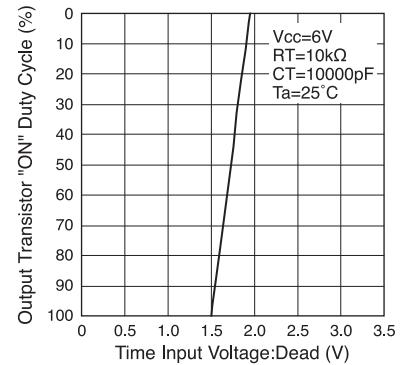

Fig. 18 Output transistor ON duty vs. Dead time voltage (BA9741F/FS/BA9743AFV)

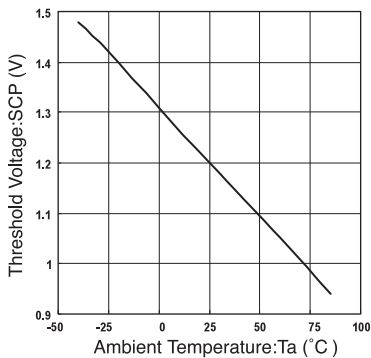

Fig. 19 Protection circuit characteristics (BA9744FV)

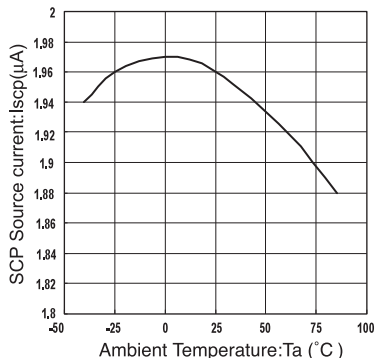

Fig. 20 Protection circuit characteristics (BA9744FV)

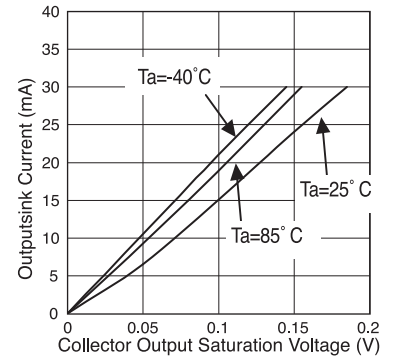

Fig. 21 Output current vs. Collector saturation voltage (BA9744FV)

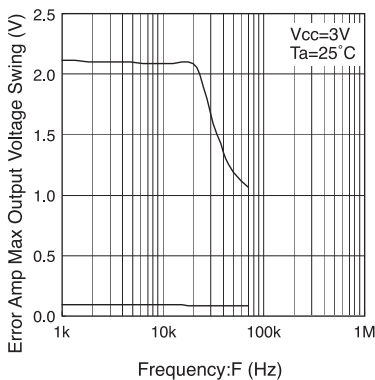

Fig. 22 Error amp. Output voltage vs. Amplitude frequency (BA9744FV)

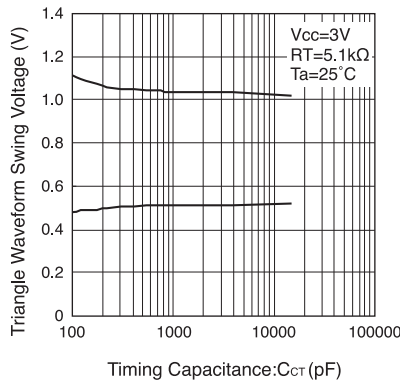

Fig. 23 Triangular wave amplitude vs. Timing capacitor (BA9744FV)

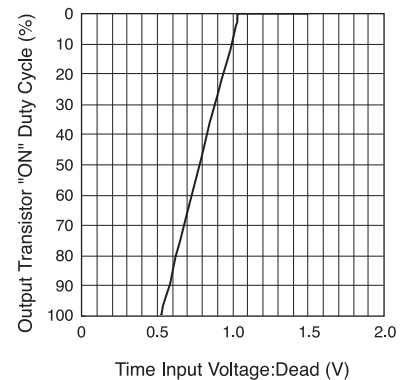

Fig. 24 Output transistor ON duty vs. Dead time voltage (BA9744FV)

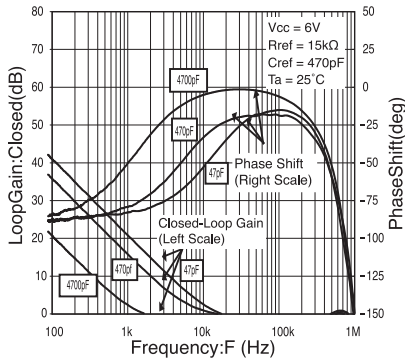

Fig. 25 Closed loop gain vs. Phase frequency (BA9741F/FS/BA9743AFV)

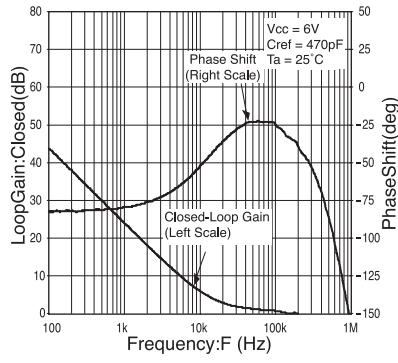

Fig. 26 Closed loop gain vs. Phase frequency (BA9741F/FS/BA9743AFV)

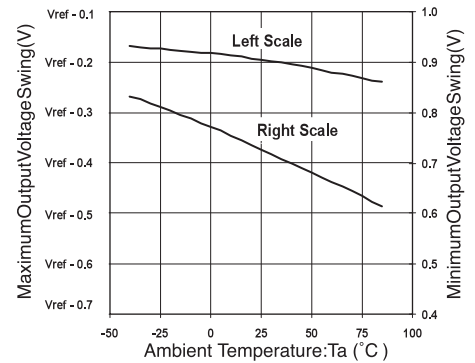

Fig. 27 Maximum output voltage amplitude vs. Ambient temperature (BA9741F/FS/BA9743AFV)

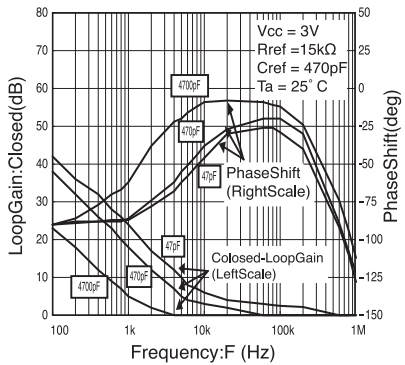

Fig. 28 Closed loop gain vs. Phase frequency (BA9744FV)

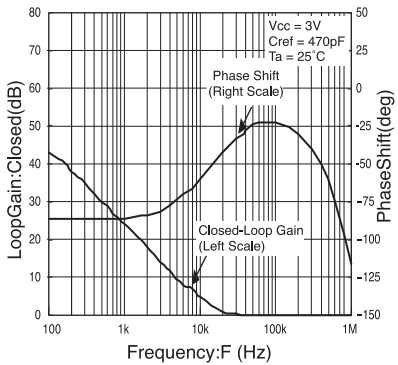

Fig. 29 Closed loop gain vs. Phase frequency (BA9744FV)

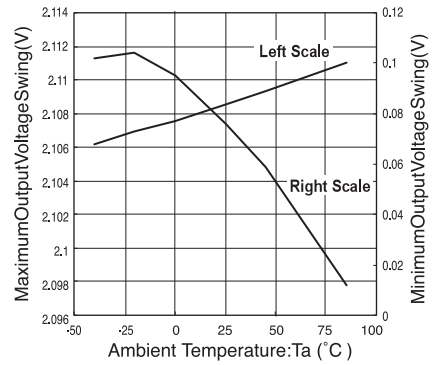

Fig. 30 Maximum output voltage amplitude vs. Ambient temperature (BA9744FV)

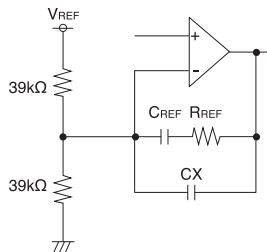

Fig.25 Test Circuit

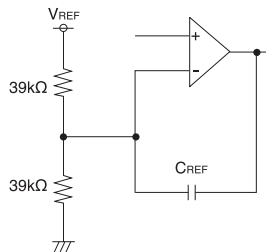
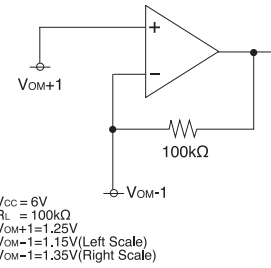

Fig.26 Test Circuit



Vcc = 6V  
R<sub>L</sub> = 100kΩ  
V<sub>OM+</sub> = 1.25V  
V<sub>OM-</sub> = 1.15V (Left Scale)  
V<sub>OM-</sub> = 1.35V (Right Scale)

Fig.27 Test Circuit

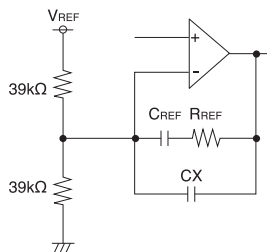

Fig.28 Test Circuit

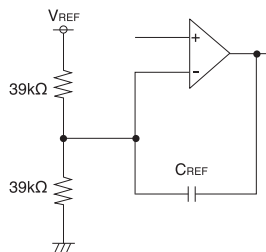
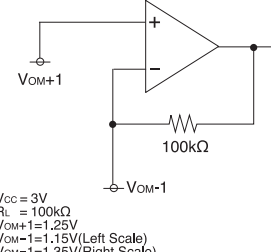

Fig.29 Test Circuit



Vcc = 3V  
R<sub>L</sub> = 100kΩ  
V<sub>OM+</sub> = 1.25V  
V<sub>OM-</sub> = 1.15V (Left Scale)  
V<sub>OM-</sub> = 1.35V (Right Scale)

Fig.30 Test Circuit

● Block diagram/Pin assignment

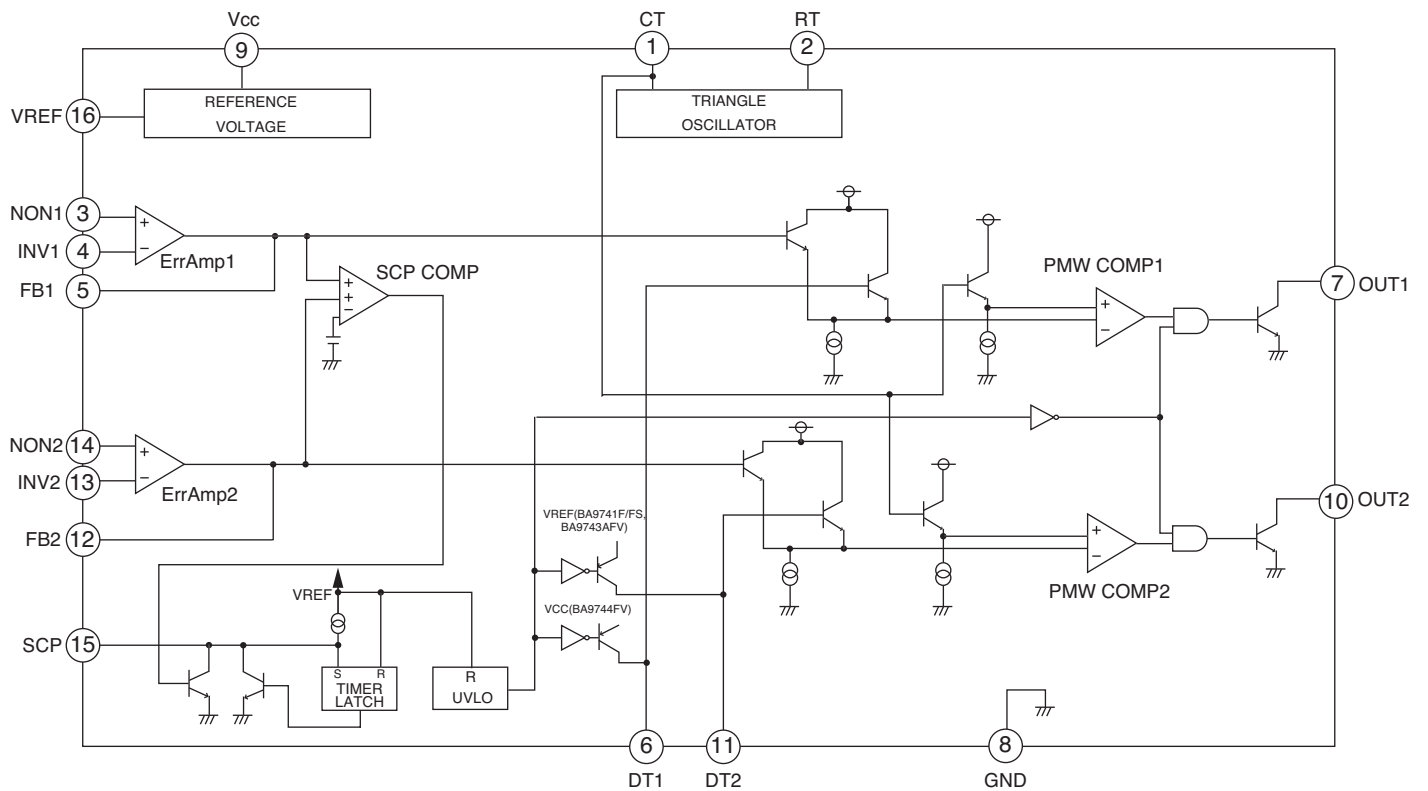
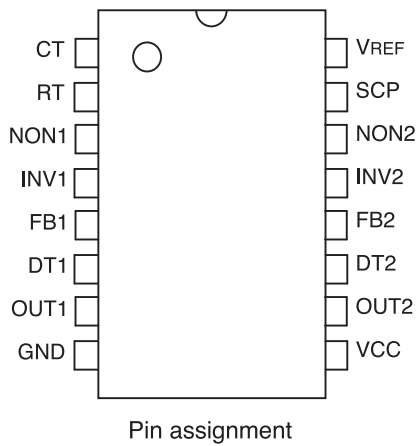

Fig.31



PIN No.	Pin name	Function
1	CT	External timing capacitance
2	RT	External timing resistance
3	NON 1	Positive input for error amplifier 1
4	INV 1	Negative input for error amplifier 1
5	FB 1	Output for error amplifier 1
6	DT 1	Output 1 dead time/soft start setting
7	OUT 1	Output 1
8	GND	GROUND
9	VCC	Power supply
10	OUT 2	Output 2
11	DT 2	Output 2 dead time / soft start setting
12	FB 2	Output for error amplifier 2
13	INV 2	Negative input for error amplifier 2
14	NON 2	Positive input for error amplifier 2
15	SCP	Timer latch setting
16	VREF	Reference voltage output



● Description of operations

1) REFERENE VOLTAGE (Reference voltage section)

From the power supply voltage input through the VCC pin (pin 9), a reference voltage, which is stabilized at the VREF, is supplied as the operating power supply voltage for the internal circuits of the IC and, at the same time, output through the VREF pin (pin 16).

2) ErrAmp1/2 (Error amplifiers)

In the case of step up / step down application, the non-inverting input pins NON1 and NON2 are used to detect the output voltage by feeding back the voltage from the final output stage (i.e., loading side). R1 and R2, which are connected to these pins, are resistors used to control the output voltage. The voltage applied to the inverting input pins INV1 and INV2 as a reference input voltage of the error amplifiers themselves, should be the voltage obtained by dividing the reference voltage (VREF) by resistance.

$$\left( V_{REF} \frac{R4}{R3 + R4} \right)$$

Furthermore, the resistor Rf and the capacitor Cf, connected between the FB1/2 (Pin 5/12) and INV1/2 (Pin 6/11), are used for feedback of the error amplifier, enabling settings of any desired level of loop gain.

It is recommended to provide AC feedback using the capacitor Cf and the resistor Rf as the feedback for the error amplifier. The amplifier output pins FB1 and FB2 are connected to the PWM and SCP comp., and used as the non-inverting input pins. The output voltage (Vo) setting is shown below:

$$V_o = \frac{R1 + R2}{R2} \times \left( V_{REF} \frac{R4}{R3 + R4} \right)$$

Since the input range VOM of the NON and INV pins is 0.3V to 1.6V (for BA9741F/FS / BA9743AFV) or 0.3V to 1.5V (for BA9744FV), it is recommended to set the range to approximately VREF/2, i.e., as shown below.

$$\left. \begin{aligned} V_{REF} \frac{R4}{R3 + R4} &\cong 1.25V \text{ (BA9741F/FS/BA9743AFV)} \\ &\cong 0.6V \text{ (BA9744FV)} \end{aligned} \right\}$$

3) Triangle Oscillator (Triangular wave oscillator section)

Used to generate a triangular waveform to be input in the PWM comp. 1/2.

The oscillator circuit charges/discharges the timing capacitor CCT that is connected between the CT pin (pin 1) and the GND at a constant current, set with resistor RRT that is connected between the RT pin (pin 2) and the GND. The triangular waveform is obtained through detecting and resetting this charged/discharged voltage.

The oscillation frequency is given through the external CCT and RRT pins by the formula shown below (BA9741F/FS/BA9743AFV):

$$f_{osc} \cong \frac{V_{RT}}{2 \cdot C_{CT} \cdot R_{RT} \cdot \Delta V_{osc}} \cong \frac{1}{(C_{CT} \cdot R_{RT})}$$

V<sub>RT</sub>: RT pin voltage 1V<sub>typ</sub>  
 ΔV<sub>osc</sub>: Triangular wave amplitude voltage = V<sub>t0</sub> - V<sub>t100</sub> = 0.49V<sub>typ</sub>

(BA9744FV)

$$f_{osc} \cong \frac{V_{RT}}{2 \cdot C_{CT} \cdot R_{RT} \cdot \Delta V_{osc}} \cong \frac{1}{(C_{CT} \cdot R_{RT})}$$

V<sub>RT</sub>: RT pin voltage 0.6V<sub>typ</sub>  
 ΔV<sub>osc</sub>: Triangular wave amplitude voltage = V<sub>t0</sub> - V<sub>t100</sub> = 0.52V<sub>typ</sub>

However, at high frequencies, since delay in the internal circuit results in an error against the formula, set oscillation frequency according to the f<sub>osc</sub> - R<sub>RT</sub> graph shown below:

Furthermore, this triangular wave can be output through the CT pin (pin 1).

Range of standard external CCT and RRT pins

R<sub>RT</sub>: 5.1kΩ at minimum to 50kΩ at maximum (BA9741F/FS / BA9743AFV) or 3kΩ at minimum to 15kΩ at maximum (BA9744FV)  
 C<sub>CT</sub>: 100pF at minimum to 15000pF at maximum

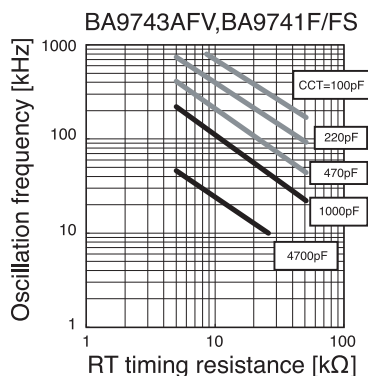

Fig.33

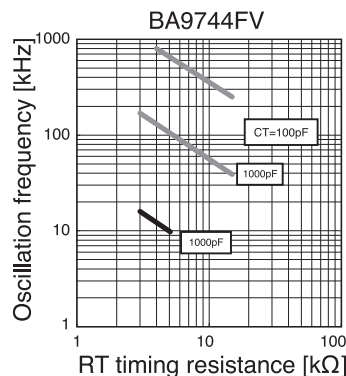

Fig.34

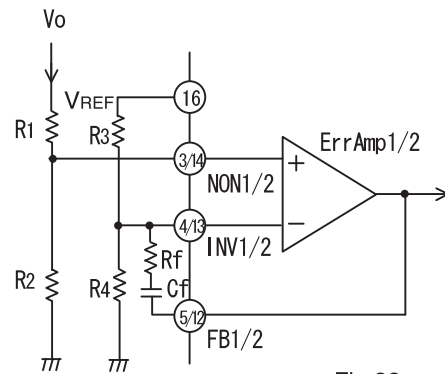

Fig.32

4) SCP Comp (Timer-latch type short-circuit prevention circuit)

When the output voltage malfunctions because of a short circuit, this function is used to turn OFF the output transistor forcedly, in order to protect the system. If the output voltage drops in reaction to the set voltage level, an error will be amplified through the Err Amp and the voltage at the FB1/FB2 pins will reach the low voltage side. If SCP Comp sets the voltage below the threshold level for either the FB1 or FB2, (i.e., 1.05Vtyp for the BA9741F/FS / BA9743AFV or 0.25Vtyp for the BA9744FV), the short prevention circuit will be activated to start the charging of the capacitor of SCP pin. When  $V_{IT}=1.64V_{typ}$  for the BA9741F/FS / BA9743AFV or  $V_{IT}=1.18V_{typ}$  for the BA9744FV is achieved, the output transistor will turn OFF.

The time is set by the capacitor (Cscp) connected to the SCP (pin 15).  
The time TSCP is obtained by the formula shown below:

$$t_{SCPT} = \frac{V_{IT} + V_{STB}}{I_{SCP}} \cdot C_{SCP}$$

For example, in the case of the BA9743AFV, assuming that  $C_{SCP}=0.1\mu F$ ,  $V_{IT}=1.64V$ ,  $V_{STB}=0.05V$  and  $I_{SCP}=2.5\mu A$ .

$$t_{SCPT} = \frac{1.64 - 0.05}{2.5\mu} \times 0.1\mu = 63.6mS$$

In order to stop the function of the short prevention circuit, short-circuit the SCP pin to GND

5) PWM Comp 1/2 DEAD TIME (Rest period adjustment circuit / Dead time)

This function can be set by dividing the resistance of DT1 and DT2 pins (pins 6 and 11) between VREF and GND. With PWM Comp, comparing the dead time voltage input and the error voltage from the Err Amp with the triangular wave, the output drive transistors are turned ON/OFF.

When Dead time voltage > Error voltage, the output duty is determined by the dead time voltage.  
The dead time voltage VDT is obtained by the expression shown below

$$V_D = V_{REF} \cdot \frac{R_2}{R_1 + R_2}$$

(BA9741F/FS/BA9743AFV)

When  $V_{DT}=1.48V_{typ}$ : Duty 100%  
When  $V_{DT}=1.97V_{typ}$ : Duty 0%  
(Provided, however, that  $f_{osc}=10kHz$ )

(BA9744FV)

When  $V_{DT}=0.49V_{typ}$ : Duty 100%  
When  $V_{DT}=1.01V_{typ}$ : Duty 0%  
(Provided, however, that  $f_{osc}=10kHz$ )

Note: If the oscillation frequency is at a high level, the upper/lower limits ( $V_{t0}/V_{t100}$ ) of the triangular wave will be shifted in the direction in which the amplitude is developed.

6) PWM Comp 1/2 SS (Soft start function)

By connecting the resistors R1 and R2, and the capacitor CDT to DT pins (pins 6 and 11), as shown in figure on the right, the soft start function is enabled.

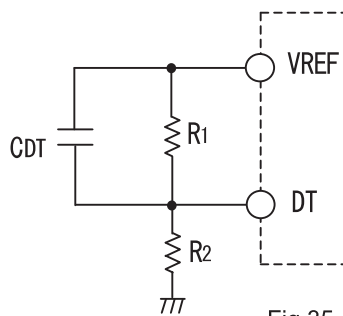
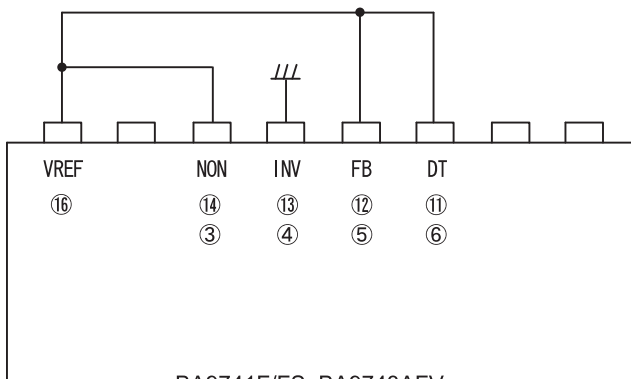
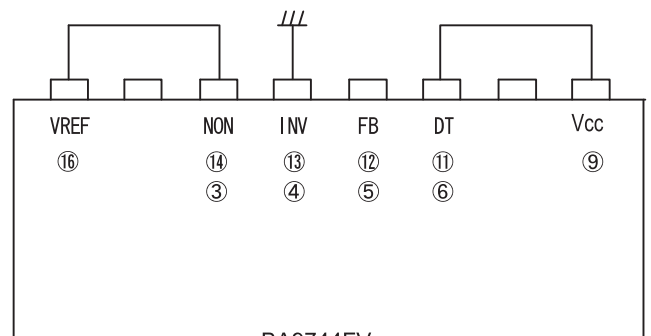

Fig.35

7) Handling of pins of unused channel



BA9741F/FS, BA9743AFV  
Fig.36



BA9744FV  
Fig.37

If channel 1 is only used, the unused channel should be handled as shown above.

● Typical application circuit

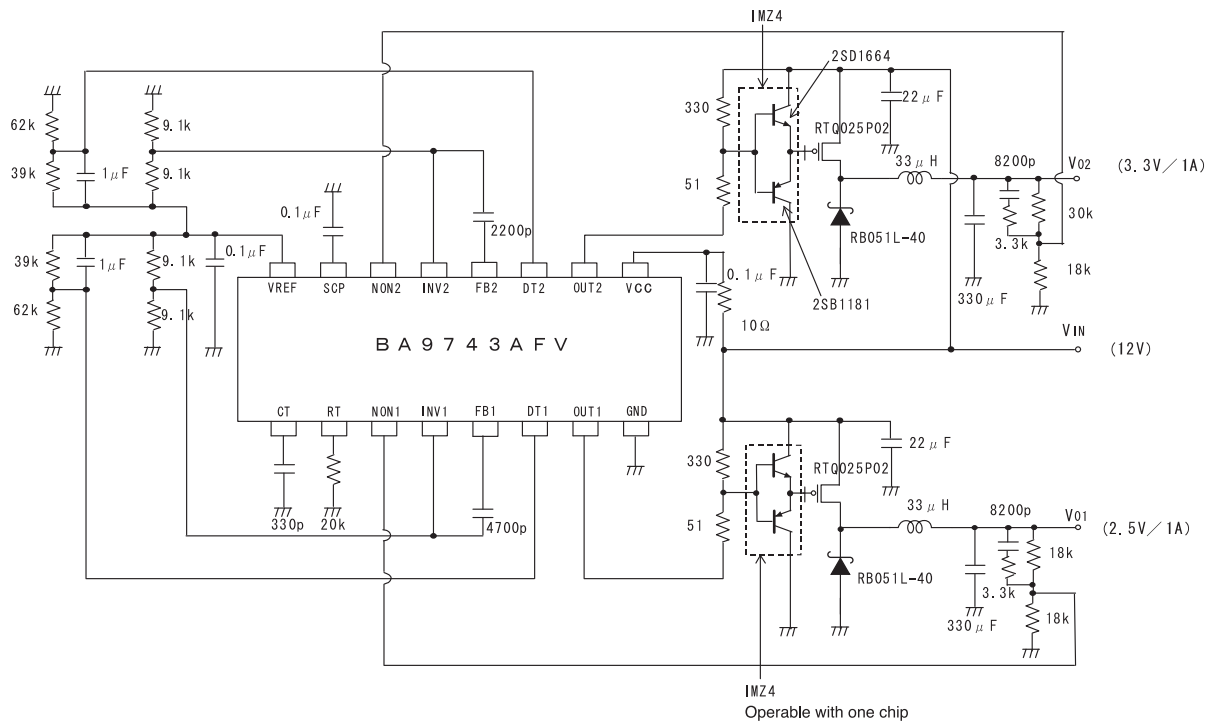

Fig. 38

1) Setting the coil (L) and capacitor (Co) of output section

The settings of the coil and capacitor with the step down application are made as shown below:.

<Setting of L value>

If the load current increases, a current will continuously flow through the coil, thus holding the relational formulas (1).

$$L = \frac{T_s}{\Delta I_L} \times \frac{(V_{IN} - V_o) \times V_o}{V_{IN}} \quad (1)$$

$V_{IN}$  : Input voltage  
 $T_s$  :  $1/(\text{Oscillation frequency})$   
 $\Delta I_L$  : Ripple current of coil

$\Delta I_L$  should typically be set to 30% or less than the maximum output current ( $I_{omax}$ ).

Increasing the L value decreases the ripple current ( $\Delta I_L$ ). Generally, the larger the L value, the smaller the allowable current of coil. Consequently, since the ripple current exceeding the allowable current results in variations in the L value, check for the appropriate current value with the coil manufacturer.

<Setting of output capacitor Co>

The output capacitor Co should be selected according to the ESR (Electric Series Resistance) characteristics of the capacitor.

For the output ripple voltage ( $\Delta V_o$ ), the following formula is held according to the ESR of the output capacitor:

$$\Delta V_o \cong \Delta I_L \times \text{ESR}$$

ESR: Series resistance of the output capacitor Co

A ripple component, due to the output capacitor, is significantly small in comparison to that due to the ESR.

Even though the Co value should meet the condition of  $1/(3 \cdot T_s) > 1/2\pi (L \times Co)^{1/2}$ , it is recommended to use a capacitor with a high enough capacitance value, to meet the ESR condition.

<Switching element>

The switching element should be determined according to the peak current. The peak current  $I_{sw}(\text{peak})$  flowing through the switching element is equal to that flowing through the coil, thus holding the formula shown below:

$$I_{sw}(\text{peak}) = I_o + \Delta I_L/2$$

Select a switching element that has an allowable current that is twice (or more) as large as the peak current obtained by the formula shown above. Furthermore, with consideration given to overcurrent caused by output short-circuited, provide an application for overcurrent protection, wherever necessary.

2) Typical standby circuit

The typical standby circuit is shown in the dotted frame below.

An additional switch is typically mounted between the power supply (VIN) and the IC power supply pin (VCC).

Controlling the switch so that Tr1 and Tr2 will turn OFF when the standby circuit is activated, reduces current flow in standby mode.

It is recommended to set the Rvcc to 10Ω and the Cvcc to 0.1μF.  
 Set Rvcc and the Cvcc within the range of 1 to 100Ω and 0.1 to 100μF.  
 Providing additional Rvcc and Cvcc helps to cut noises from the VIN line.

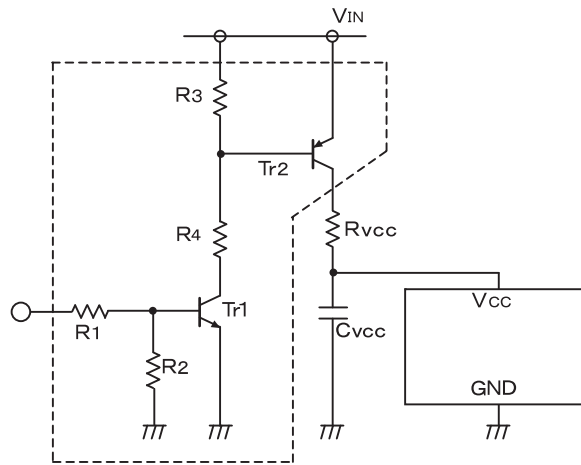

Typical standby circuit Fig.39

3) Typical overcurrent protection circuit

Insert sensing resistors between FET source and VIN of the channel P of output section, as shown in figure on the right, to detect an overcurrent.

$$I_{max} = \frac{V_f}{R_S}$$

If any sensing resistor detects an overcurrent, the composite digital transistor, shown in figure on the right, will turn ON to set the DT pin to "H", thus turning OFF the output.

Once the DT pin has been set to "H", soft start (restart) mode is enabled through an external capacitor. Furthermore, if an overcurrent flows through the circuit, latching will be enabled through connecting the digital transistor PNP collector to the SCP pin (pin 15).

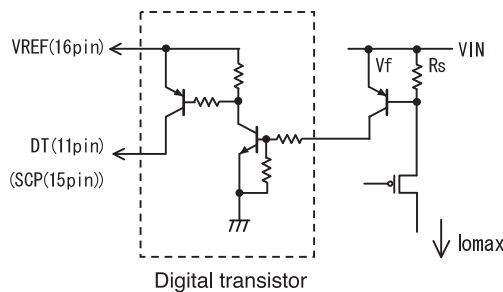

Digital transistor  
 Typical overcurrent protection circuit Fig.40

4) Typical application of Master/Slave operation circuit

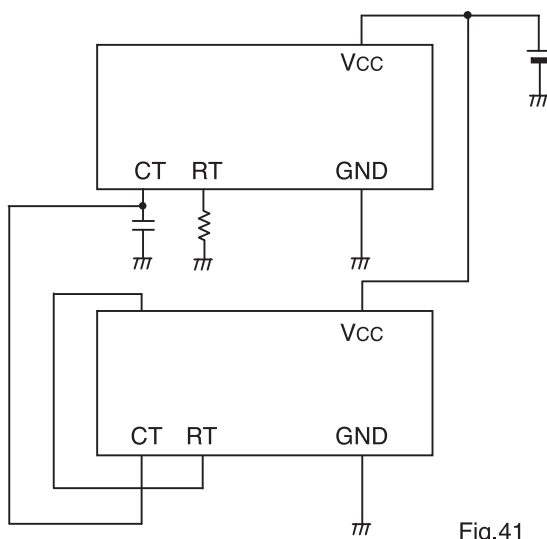

Fig.41

Caution:

The oscillation frequency should be determined according to capacitors and resistors connected to the CT pin (pin 1) and RT pin (pin 2) on the master IC.

However, increasing the number of slave ICs, increases the parasitic capacitance of these ICs in contact with the CT pin, resulting in a drift of oscillation frequency.

● Equivalent circuit

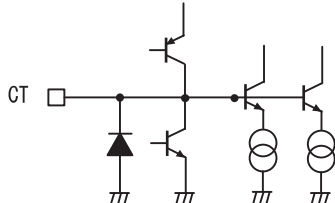
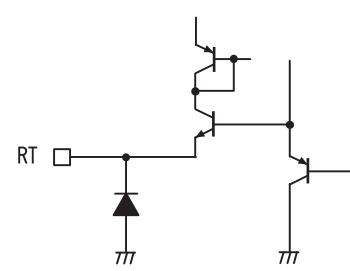
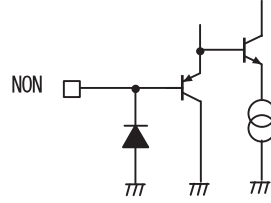
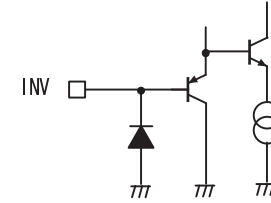
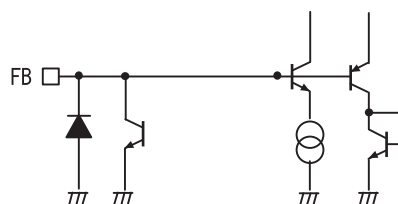
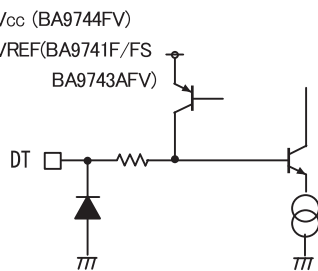
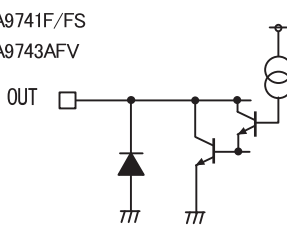
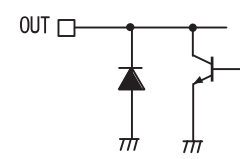
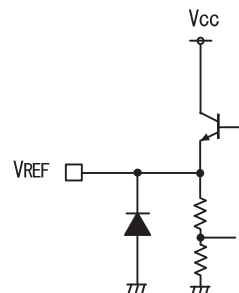
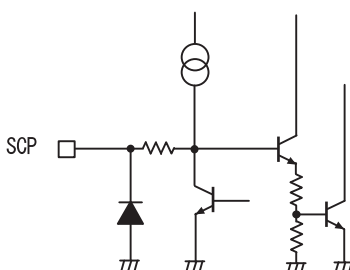
<p>1PIN(CT)</p> 	<p>2PIN(RT)</p> 
<p>3, 14PIN(NON1, NON2)</p> 	<p>4, 13PIN(INV1, INV2)</p> 
<p>5, 12PIN(FB1, FB2)</p> 	<p>6, 11PIN(DT1, DT2)</p> <p>Vcc (BA9744FV) VREF(BA9741F/FS BA9743AFV)</p> 
<p>7, 10PIN(OUT1, OUT2)</p> <p>BA9741F/FS BA9743AFV</p> 	<p>7, 10PIN(OUT1, OUT2)</p> <p>BA9744FV</p> 
<p>16PIN(VREF)</p> <p>Vcc</p> 	<p>15PIN(SCP)</p> 

● Equivalent circuit

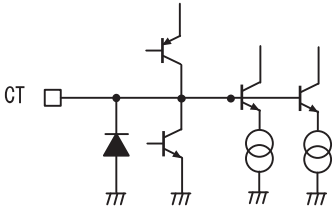
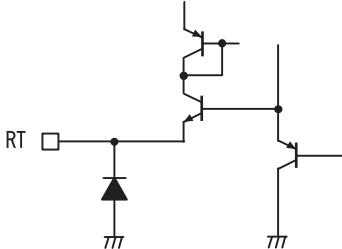
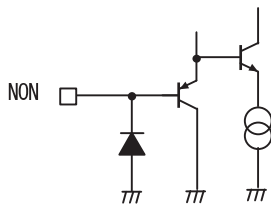
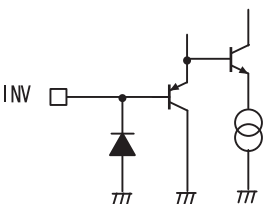
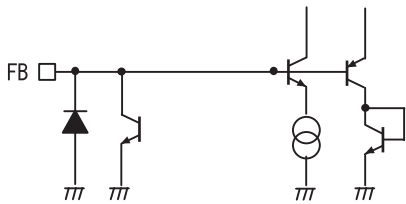
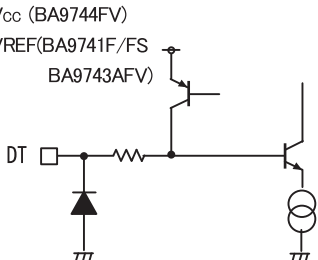
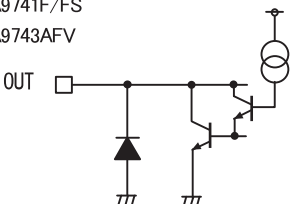
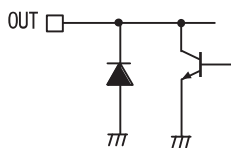
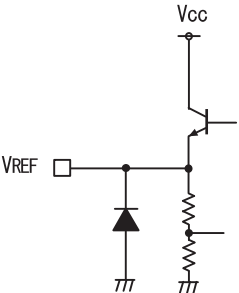
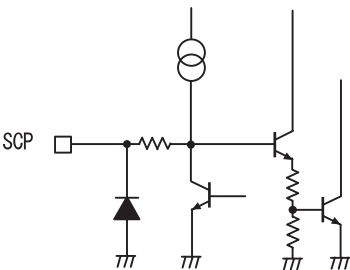
<p>1PIN (CT)</p> 	<p>2PIN (RT)</p> 
<p>3, 14PIN (NON1, NON2)</p> 	<p>4, 13PIN (INV1, INV2)</p> 
<p>5, 12PIN (FB1, FB2)</p> 	<p>6, 11PIN (DT1, DT2)</p> <p>V<sub>CC</sub> (BA9744FV) VREF(BA9741F/FS BA9743AFV)</p> 
<p>7, 10PIN (OUT1, OUT2)</p> <p>BA9741F/FS BA9743AFV</p> 	<p>7, 10PIN (OUT1, OUT2)</p> <p>BA9744FV</p> 
<p>16PIN (VREF)</p> 	<p>15PIN (SCP)</p> 

## ● Heat dissipation characteristics

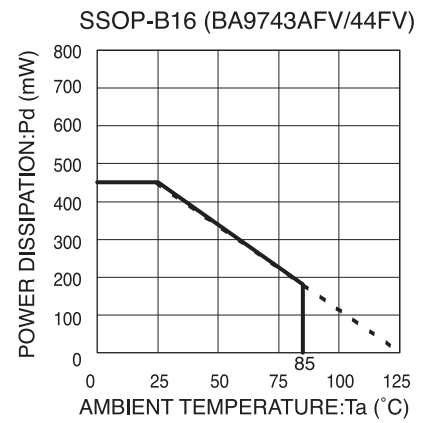
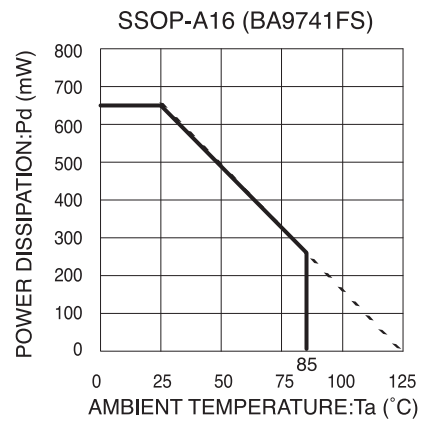
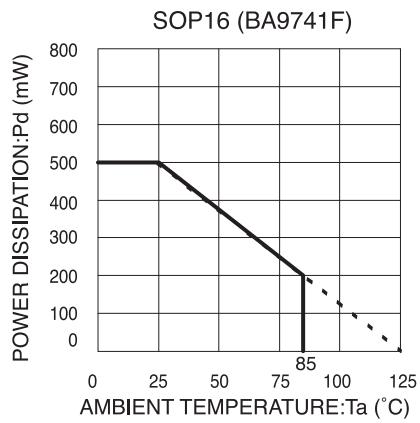

Note: When mounted on a printed circuit board of 70.0×70.0×1.6 mm (SOP16 and SSOP-A16)

When mounted on a printed circuit board of 50.0×50.0×1.6 mm (SSOP-B16)

●Ordering part number

B	A	9	7	4	3	A	F	V	-	E	2	
Part No.		Part No.					Package		Packaging and forming specification			
		9743A 9744 9741					FV:SSOP-B16 FS:SSOP-A16 F:SOP16		E2: Embossed tape and reel			

SSOP-B16

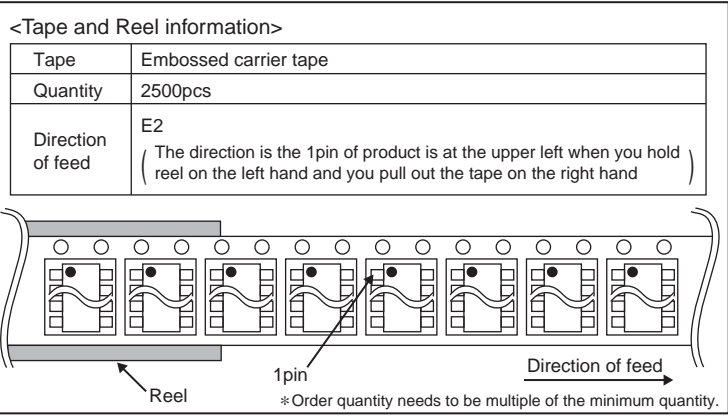
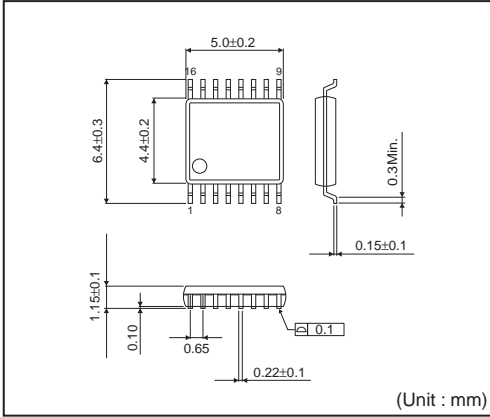

SSOP-A16

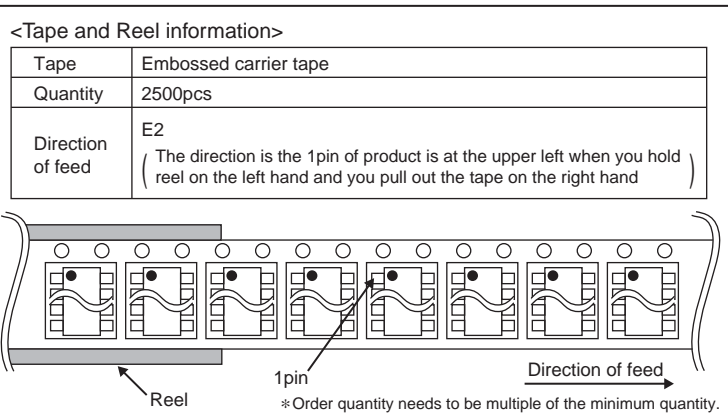
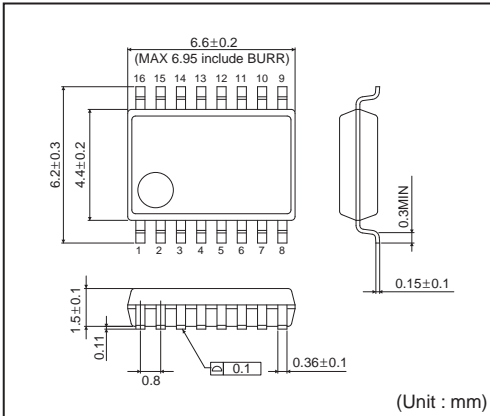

SOP16

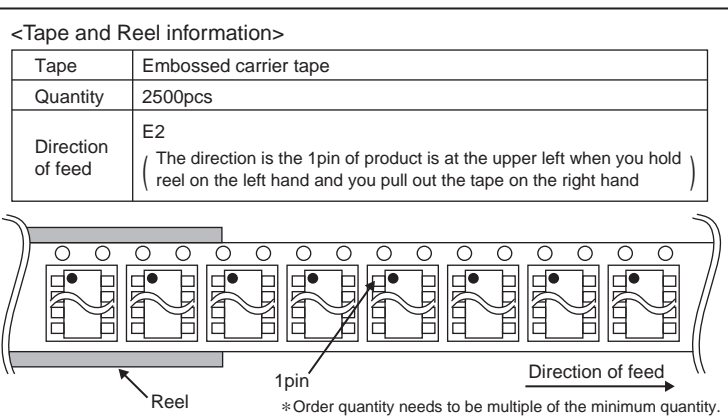
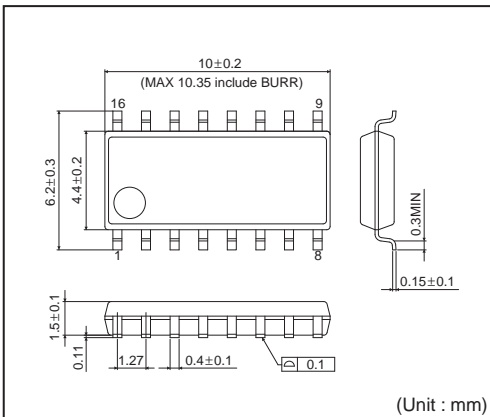



## Notes

No copying or reproduction of this document, in part or in whole, is permitted without the consent of ROHM Co.,Ltd.

The content specified herein is subject to change for improvement without notice.

The content specified herein is for the purpose of introducing ROHM's products (hereinafter "Products"). If you wish to use any such Product, please be sure to refer to the specifications, which can be obtained from ROHM upon request.

Examples of application circuits, circuit constants and any other information contained herein illustrate the standard usage and operations of the Products. The peripheral conditions must be taken into account when designing circuits for mass production.

Great care was taken in ensuring the accuracy of the information specified in this document. However, should you incur any damage arising from any inaccuracy or misprint of such information, ROHM shall bear no responsibility for such damage.

The technical information specified herein is intended only to show the typical functions of and examples of application circuits for the Products. ROHM does not grant you, explicitly or implicitly, any license to use or exercise intellectual property or other rights held by ROHM and other parties. ROHM shall bear no responsibility whatsoever for any dispute arising from the use of such technical information.

The Products specified in this document are intended to be used with general-use electronic equipment or devices (such as audio visual equipment, office-automation equipment, communication devices, electronic appliances and amusement devices).

The Products specified in this document are not designed to be radiation tolerant.

While ROHM always makes efforts to enhance the quality and reliability of its Products, a Product may fail or malfunction for a variety of reasons.

Please be sure to implement in your equipment using the Products safety measures to guard against the possibility of physical injury, fire or any other damage caused in the event of the failure of any Product, such as derating, redundancy, fire control and fail-safe designs. ROHM shall bear no responsibility whatsoever for your use of any Product outside of the prescribed scope or not in accordance with the instruction manual.

The Products are not designed or manufactured to be used with any equipment, device or system which requires an extremely high level of reliability the failure or malfunction of which may result in a direct threat to human life or create a risk of human injury (such as a medical instrument, transportation equipment, aerospace machinery, nuclear-reactor controller, fuel-controller or other safety device). ROHM shall bear no responsibility in any way for use of any of the Products for the above special purposes. If a Product is intended to be used for any such special purpose, please contact a ROHM sales representative before purchasing.

If you intend to export or ship overseas any Product or technology specified herein that may be controlled under the Foreign Exchange and the Foreign Trade Law, you will be required to obtain a license or permit under the Law.



Thank you for your accessing to ROHM product informations.  
More detail product informations and catalogs are available, please contact us.

## ROHM Customer Support System

<http://www.rohm.com/contact/>